

# OPERATING MANUAL

## Pro SC5x9x

Universal Scanner  
Multichannel Data Logger  
Model No.: SC5x9x



Manufacturers of :

- Circular Chart Recorders
- Inkless Recorders
- Paperless Recorders
- Scanners & Data Loggers
- Networked Data Loggers
- Application Software
- WHO PQS Qualified Data Loggers
- Vaccine Series Data Loggers

**G-TEK CORPORATION PVT. LTD.**

"Gunaji House"  
Plot No. 25/1, Besides Status Bungalow,  
Padra Road, Vadodara – 391410.  
tel.: +91-98245 24140  
e-mail: [info@gtek-india.com](mailto:info@gtek-india.com)  
url: [www.gtek-india.com](http://www.gtek-india.com)

# CONTENTS

---

<b>1</b>	<b>List of Figures.....</b>	<b>1-2</b>
<b>2</b>	<b>List of Tables.....</b>	<b>2-2</b>
<b>3</b>	<b>Introduction .....</b>	<b>3-3</b>
3.1	Manual Layout .....	3-3
3.2	Scanner Description.....	3-4
3.3	Optional Features .....	3-4
3.4	Unpacking and Inspection of Scanner .....	3-5
<b>4</b>	<b>Installation .....</b>	<b>4-7</b>
4.1	Electrical Installation.....	4-10
4.1.1	General information .....	4-10
4.1.2	Wiring diagram for SC5x9x Pro .....	4-12
4.1.3	Mains Supply Connection .....	4-13
4.1.4	Sensor Wiring.....	4-14
4.1.5	Connecting Scanner with Transmitter and External Power Supply .....	4-21
4.1.6	Wiring Diagram for Relay Connection .....	4-21
4.1.7	Wiring diagram for PC interface .....	4-22
<b>5</b>	<b>Operation .....</b>	<b>5-23</b>
<b>6</b>	<b>Scanner Configuration.....</b>	<b>6-25</b>
6.1	Programming(Configuration) Sequence .....	6-27
6.2	Batch Status .....	6-28
6.2.1	Batch Start/Stop.....	6-29
6.3	Printer Setup .....	6-31
6.4	Display Setup .....	6-35
6.4.1	Display Unit.....	6-36
6.5	Mass Storage.....	6-37
6.6	Settings .....	6-37
6.6.1	Date and Time.....	6-38
6.7	Channel Skip.....	6-38
6.8	CJC capturing.....	6-39
6.8.1	Offset .....	6-39
6.8.2	Multiplier .....	6-39
6.9	Relay Setting .....	6-40
6.9.1	Alarm On Delay .....	6-40
6.9.2	Alarm Off Time.....	6-40

6.10	Channel Configuration .....	6-41
6.10.1	Sensor Type.....	6-41
6.10.2	Range low.....	6-43
6.10.3	Span .....	6-43
6.10.4	Offset .....	6-44
6.10.5	Multiplier .....	6-44
6.10.6	Resolution (Decimal Place) .....	6-44
6.10.7	Alarm Set Point High .....	6-45
6.10.8	Alarm Set Point Low.....	6-45
6.10.9	Alarm Group Selection.....	6-45
6.11	Global channel configuration.....	6-46
<b>7</b>	<b>Network .....</b>	<b>7-48</b>
7.1	Network Configuration .....	7-48
<b>8</b>	<b>Reading Current Channel Data on Modscan Application.....</b>	<b>8-52</b>
8.1	Steps to Read Current Data on Modscan .....	8-52
<b>9</b>	<b>Troubleshooting Guide.....</b>	<b>9-54</b>
<b>10</b>	<b>Accessories .....</b>	<b>10-55</b>
10.1	Panel Mounting Clamps.....	10-55
10.2	Ethernet Cable .....	10-55
<b>11</b>	<b>Specifications.....</b>	<b>11-56</b>
<b>12</b>	<b>Ordering code.....</b>	<b>12-60</b>

# 1 LIST OF FIGURES

---

Figure 1 - Front View of Scanner .....	3-5
Figure 2 - Back View of Scanner.....	3-6
Figure 3 - Side View of Scanner .....	3-6
Figure 4 - Environmental Conditions .....	4-7
Figure 5 - Overall Dimensions .....	4-8
Figure 6 - Panel Cutout .....	4-8
Figure 7 - Panel Mounting .....	4-9
Figure 8 - Wiring Diagram for Scanner Series SC5x9x Pro .....	4-12
Figure 9 - Mains Supply Connection .....	4-13
Figure 10 - Sensor Wiring.....	4-15
Figure 11 - Sensor Wiring - RTD (Pt-100) 3-Wire Input.....	4-16
Figure 12 - Sensor Wiring - RTD (Pt-100) 2-Wire Input.....	4-17
Figure 13 - Sensor Wiring - Thermocouple Input.....	4-18
Figure 14 - Sensor Wiring – Volt Input.....	4-19
Figure 15 - Sensor Wiring - 4-20mA / 0-20mA Input .....	4-20
Figure 16 - Connecting Scanner with Transmitter and External Power Supply.....	4-21
Figure 17 - Wiring Details for Relay Connections .....	4-21
Figure 18 - Wiring Details for Ethernet Connections.....	4-22
Figure 19 - Front Panel.....	5-23
Figure 20 - Device Configuration Application .....	7-48
Figure 21 - Connect to Device.....	7-48
Figure 22 - Device Information .....	7-49
Figure 23 - Current Network Configuration.....	7-49
Figure 24 - Clear Network Configuration .....	7-50
Figure 25 - IP Changed Successfully.....	7-50
Figure 26 - Disconnect Device.....	7-51
Figure 27 - Device Disconnected Successfully .....	7-51
Figure 28 - Selection of display data format in Modscan .....	8-52
Figure 29 - Setup of device ID, Address, length and function code.....	8-52
Figure 30 - Set the Device IP address for Modbus TCP/IP communication .....	8-53
Figure 31 - Display Current channel data in floating point format.....	8-53
Figure 32 - Panel Mounting kit.....	10-55
Figure 33 - Ethernet Cable .....	10-55

# 2 LIST OF TABLES

---

Table 1 - Manual Layout .....	3-3
Table 2 - Troubleshooting Guide .....	9-54
Table 3 - Specifications .....	11-56
Table 4 - Sensor Type, Range & Accuracy.....	11-58
Table 5 - Sensor Type, Range, Error & Temp. Specification .....	11-59
Table 6 - Ordering Code .....	12-60

### 3 INTRODUCTION

---

This manual is written to help the user to familiarize with the installation and operation of the multichannel scanner of series SC5x9x Pro. The Sc5x9x Pro series of multichannel scanners are designed for reliable and convenient recording of process parameters in production, Research and Quality control applications. This Scanners can monitor up to 32\* channels at the scan rate of 'All channels/1sec'\* or 'All channels/10Sec'\*.

#### 3.1 MANUAL LAYOUT

This manual is divided into several sections for quick and easy reference.

*Table 1 - Manual Layout*

Section 1 Introduction	This gives outline of the manual, brief description about the scanner, optional features available and how to unpack it.
Section 2 Installation	This section gives the details about mechanical and electrical installation.
Section 3 Operation	This section gives the details of the front panel display and keyboard.
Section 4 Scanner Configuration	This section gives the details about various parameters that user can set using keyboard for proper monitoring requirement.
Section 5 Network	This section describes the Network configuration procedure for scanner.
Section 6 Reading Channel data on Modscan Application	This section describes the process of viewing current readings of all channels on Modscan application for Modbus TCP/IP protocol.
Section 7 Troubleshooting guide	This section describes about the most frequently asked questions and their solutions.
Section 8 Accessories	This section describes the standard accessories for the scanner along with their part nos.
Section 9 Specifications	It describes the detailed specification of the scanner.
Section 10 Ordering Code	It describes the details of order code and by comparing it with the code on the scanner, user can find out the installed options.

**\*Features and capabilities may vary depending upon the product purchased.**

## 3.2 SCANNER DESCRIPTION

The multichannel scanners SC5x9x Pro are available in multiple of eight channels with a wide range of inputs. The 20x4 line LCD display allows user to continuously monitor the current readings with good readability and settings of configurations. This multichannel scanner also has 6 multipurpose keys which enables user to easy programming/configure the unit. For the convenience of the user and to make it cost effective, universal inputs are made as an optional feature.

## 3.3 OPTIONAL FEATURES

Following optional features are available for this series of scanners.

- Relay Output: 1 relay (Common to all) or 8 relays
- Ethernet Connectivity
- USB Host Connectivity
- PC Software: GtekNet
- Number of Channels: 8, 16, 24, 32
- Scanning Speed: All channels/3 sec or All channels/15 Sec

It is possible that the scanner you received may or may not be fitted with the optional features. Please refer to the product code to know about installed options in your Scanner.

### 3.4 UNPACKING AND INSPECTION OF SCANNER

G-Tek Scanner are dispatched in a recyclable, environment friendly package specially designed to give adequate protection during transit. If the outer box shows sign of damage, it should be opened immediately, and the scanner be examined. If there is evidence of damage, the instrument should not be operated, and the local representative contacted for instructions. Ensure that all accessories and documentation is removed from the box. If the scanner is for immediate use, you can start installing it now as per following instructions. **Please preserve the original packing along with all internal packing for future transport requirements.**

#### Front View:

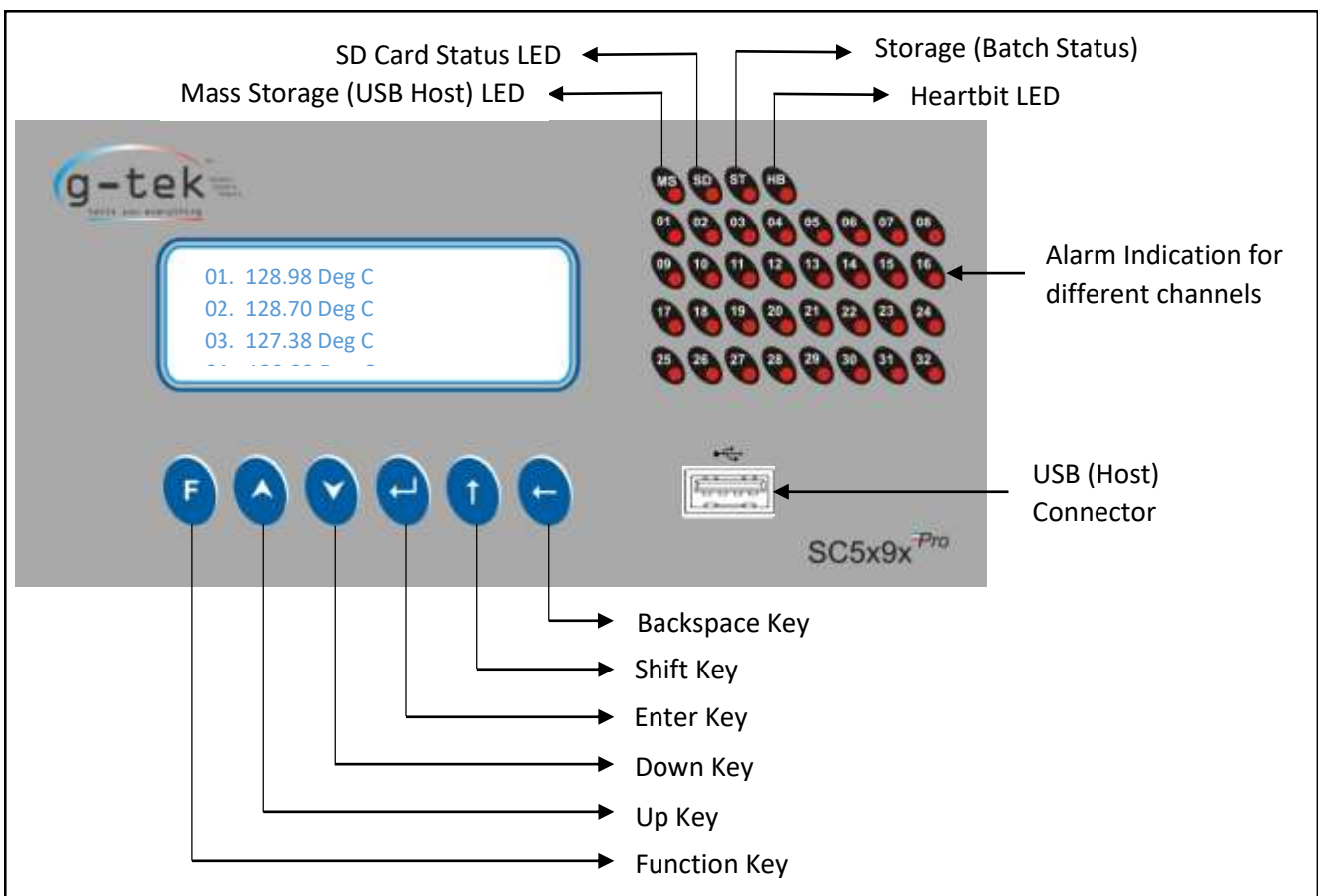
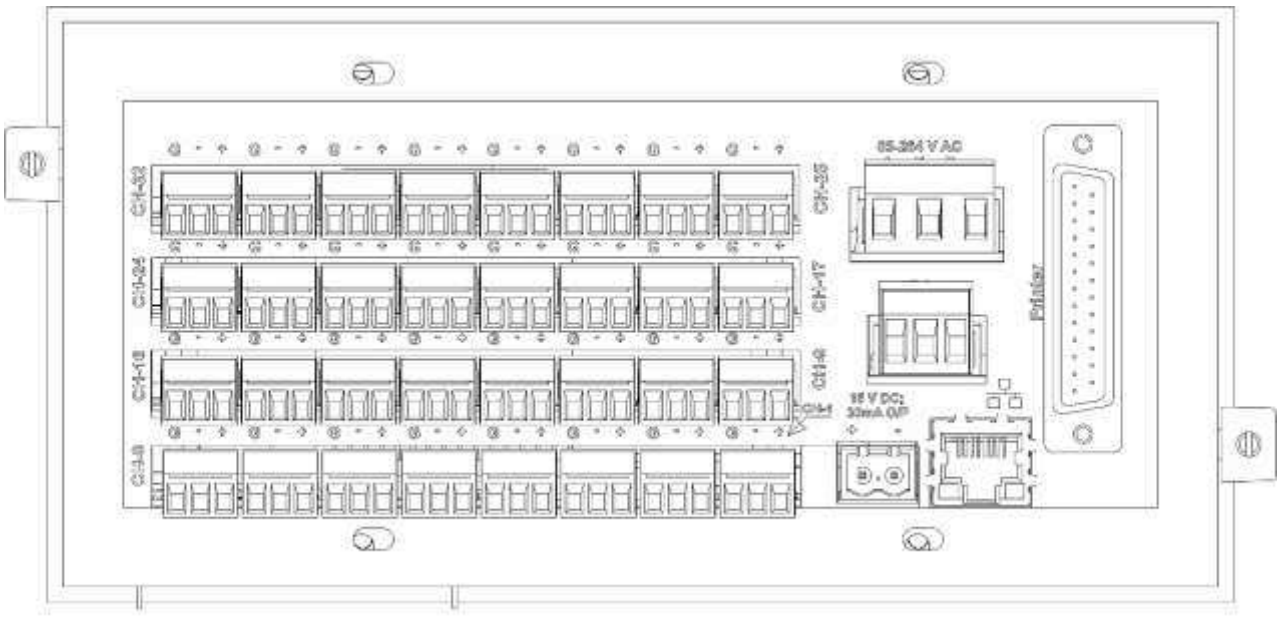
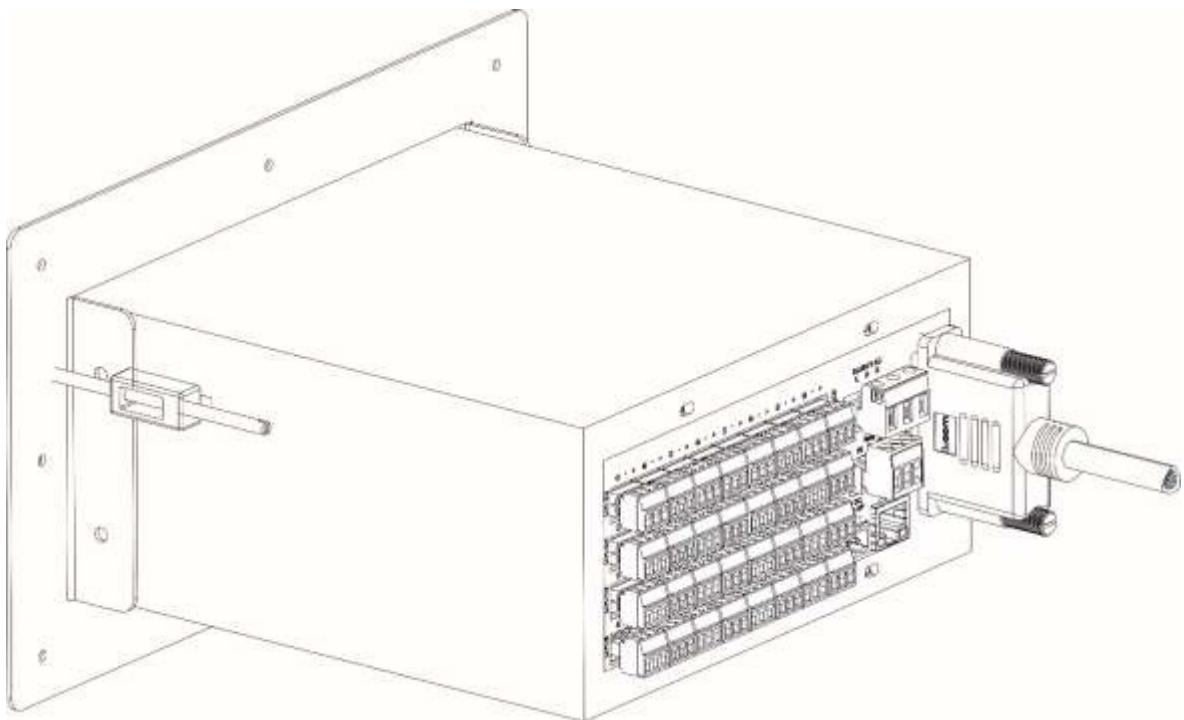

Figure 1 - Front View of Scanner

**Back View:**



*Figure 2 - Back View of Scanner*



*Figure 3 - Side View of Scanner*

## 4 INSTALLATION

### Environment Conditions

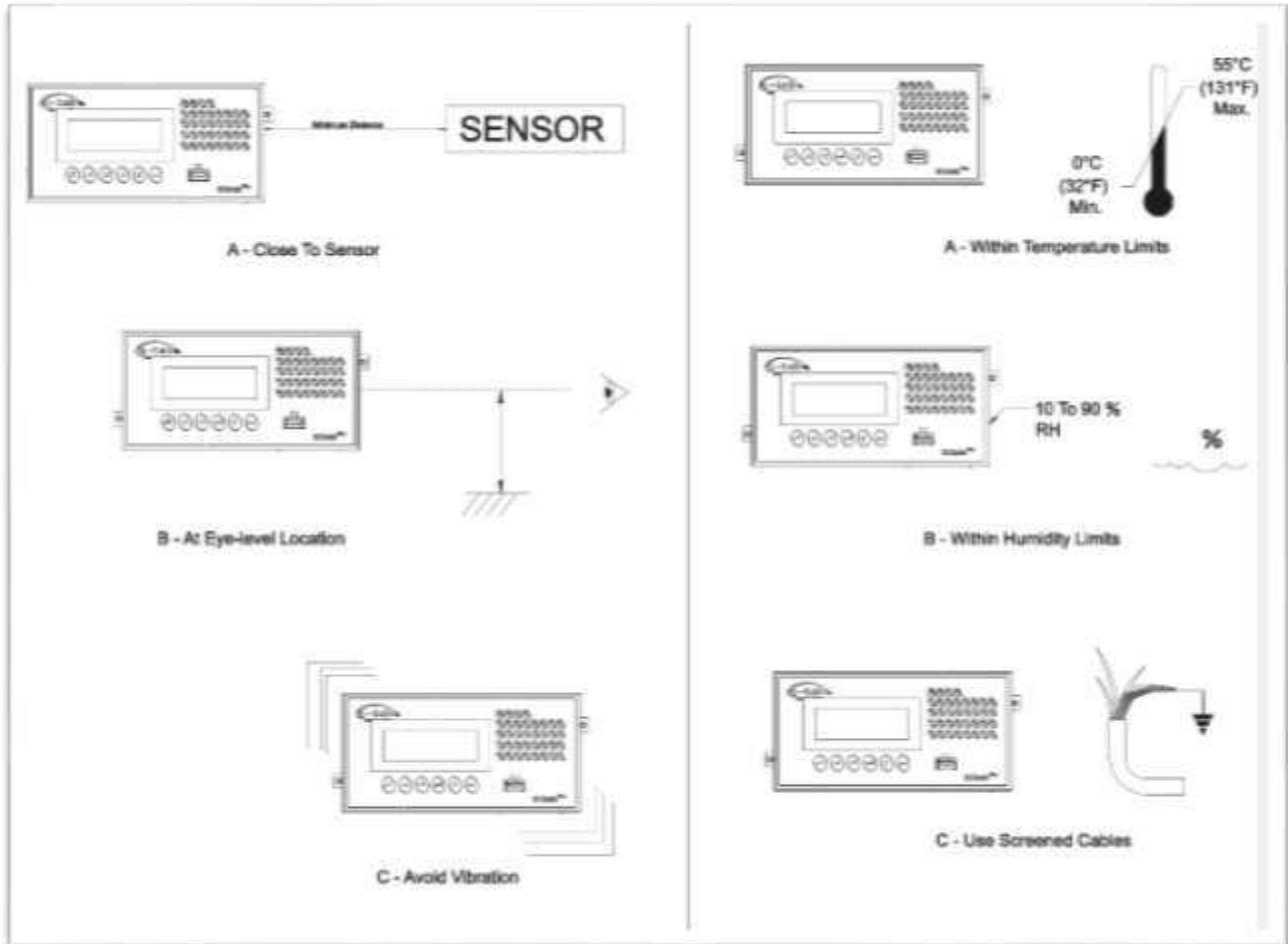

Figure 4 - Environmental Conditions

**Caution:** Select a location away from strong electrical and magnetic field. If this is not possible, particularly in application where mobile communications equipment is expected to be used, screened cables within earthed (grounded) metal contact must be used.

## Overall Dimensions

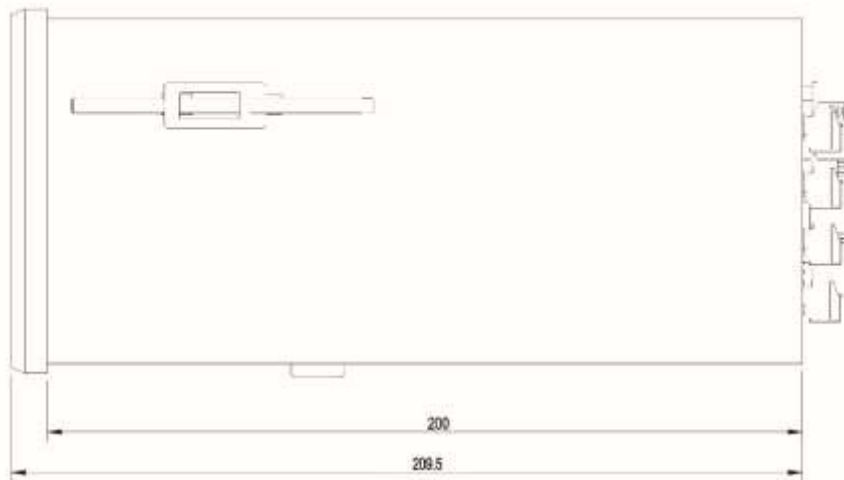
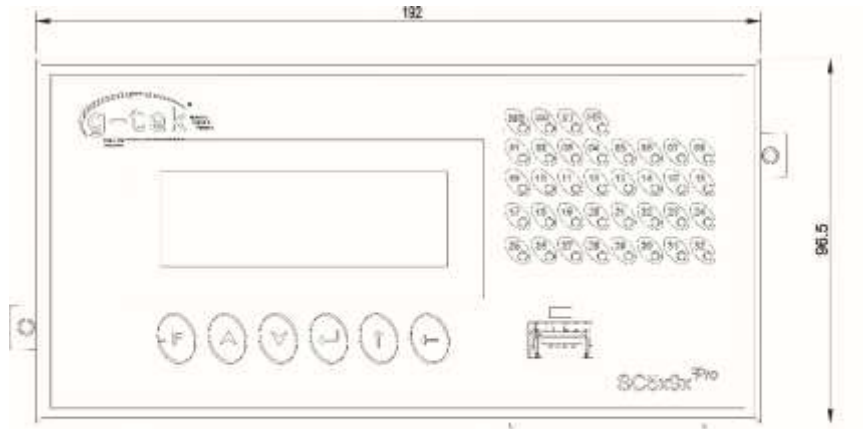

Figure 5 - Overall Dimensions

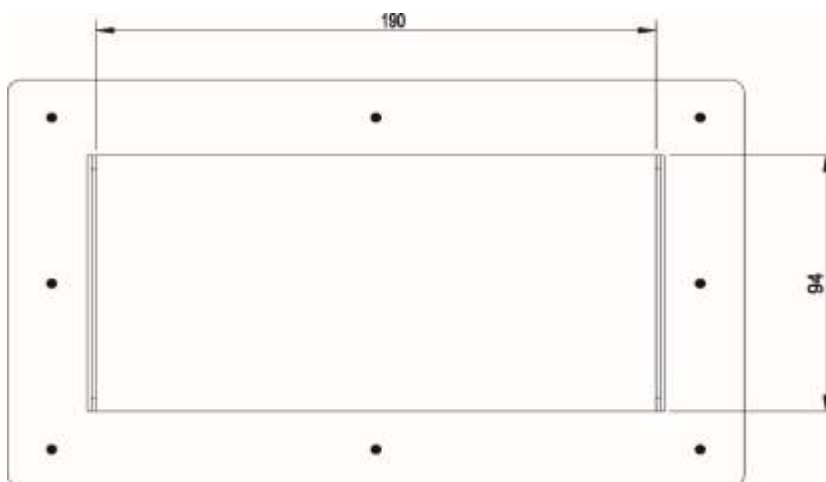
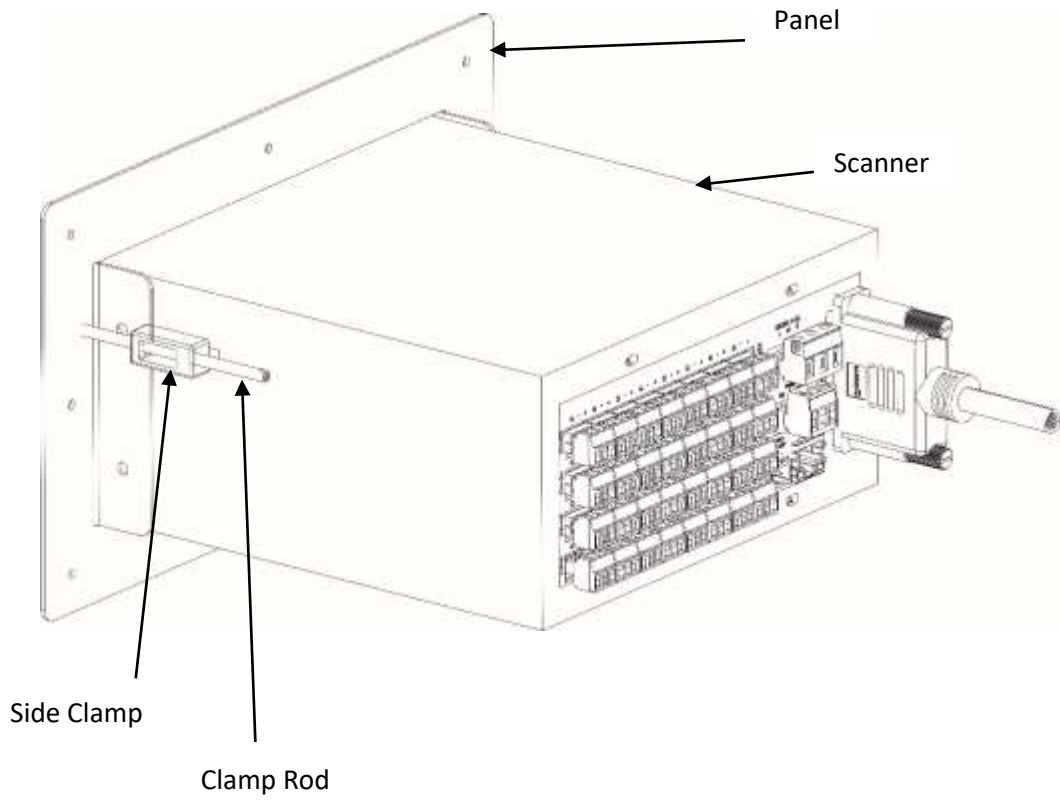

Figure 6 - Panel Cutout



*Figure 7 - Panel Mounting*

## 4.1 ELECTRICAL INSTALLATION

### 4.1.1 General information



#### Warnings

To comply with Underwriter Laboratories (UL) and Canadian Standards Association (CSA) certification, route signal leads and power cables in earthed (grounded), flexible metal conduit.

Connect proper Earth to the earthing terminal of the scanner.

- Instruments not fitted with the optional internal on/off switch and fuse must have a disconnecting device such as a switch or circuit breaker conforming to local safety standards fitted to the final installation. It must be fitted near the instrument within easy reach of the operator and must be marked clearly as the disconnection device for the instrument.
- Remove all power from supply, relay and any powered control circuits and high common mode voltages before accessing or making any connections.
- Use cable appropriate for the load currents. The terminals accept cables up to 14AWG (2.5mm<sup>2</sup>).
- The instrument and all inputs and outputs conform to Mains Power Input Insulation Category II.
- All connections to secondary circuits must have basic insulation.
- After installation, there must be no access to live parts e.g., terminals.
- Terminals for external circuits are for use only with equipment with no accessible live parts.
- If the instrument is used in a manner not specified by the Company, the protection provided by the equipment may be impaired.
- All equipment connected to the instrument's terminals must comply with local safety standards (IEC 60950, EN601010-1).

#### **NOTE:**

To ensure maximum recorder performance, proper wiring installation practices must be followed. Failure to do so can result in a range of problems, from loss of configuration to component failure, caused by transmitted or radiated electrical noise. Proper consideration must be given to local noise sources and appropriate suppression steps taken to minimize any potential problems. Among the most common sources of noise are Relays, SCRs, valve solenoids, electric motors, power line disturbance, wire-to-wire coupling, electrostatic discharge (ESD) and radio-frequency interference (RFI).

**To achieve the best results, the following notes should be considered:**

1. Low level signal wiring such as that associated with thermocouples, RTDs and current loops should always be kept separate from power and control output wiring.
2. Signal input wiring should be twisted pairs/triplets etc. The conductors should be stranded rather than solid in construction. All signal wiring should use ground-shielded wires or be routed through grounded conduit to minimize the effects of RFI and ESD.
3. Exceptional care should be taken when wiring to relay or solenoid coils, as large transients are produced when coils (or any other inductive loads like motors or arc welding equipment's etc.) are switched. This problem can be eliminated using suitable suppression devices across the coil. Coil transients can also be transmitted through the air, so the recorder itself should be mounted as far as possible from power control devices and/or wiring.
4. When line power is poorly regulated and / or subject to voltage surges or transients, consideration should be given to the use of a line conditioning/transient suppressing line power regulator. Process control motors, valves, relays, and heaters should not be connected to the same power lines that are used for instrumentation.
5. The connection of the scanner to a proper safety earth ground is essential. Such a connection not only reduces the possibility of electric shock, but also provides the required return for the scanner line power filters.
6. All local electrical codes of practice must be followed when installing any instrumentation.

## 4.1.2 Wiring diagram for SC5x9x Pro

### Check for proper Earthing:

Proper Earthing is necessary for best performance of the Scanner. Follow the steps mentioned below to check whether the earthing given to the scanner is proper or not:

- Find out the Phase line of connection with the help of “Tester with Neon Lamp”. When Neon Lamp glows, it is an indication of the phase line.
- Once Phase is found, the other hole which is in line of phase is the Neutral line.
- The third hole which is apparently bigger in diameter is the Earthing line.
- Now take the voltmeter with appropriate measurement range (normally 750VAC or higher) and put the probes into PHASE and NEUTRAL line and take reading.
- The voltage across PHASE and EARTH, and NEUTRAL and EARTH.
- The voltage between Neutral and Earth Should not be more than 6V. If by any chance, it is more than 30V, it is a serious fault on earth line. And must immediately be corrected.

**Proper Earthing is essential for safety of the personnel and for the proper functioning of the equipment.**

**Note:** If connecting the instrument in the panel, scanner and panel both should be at the same earthing potential.

### Wiring diagram for scanner:

See the back panel of the scanner, you will find all the connectors for wiring. As shown in the following figure 8.

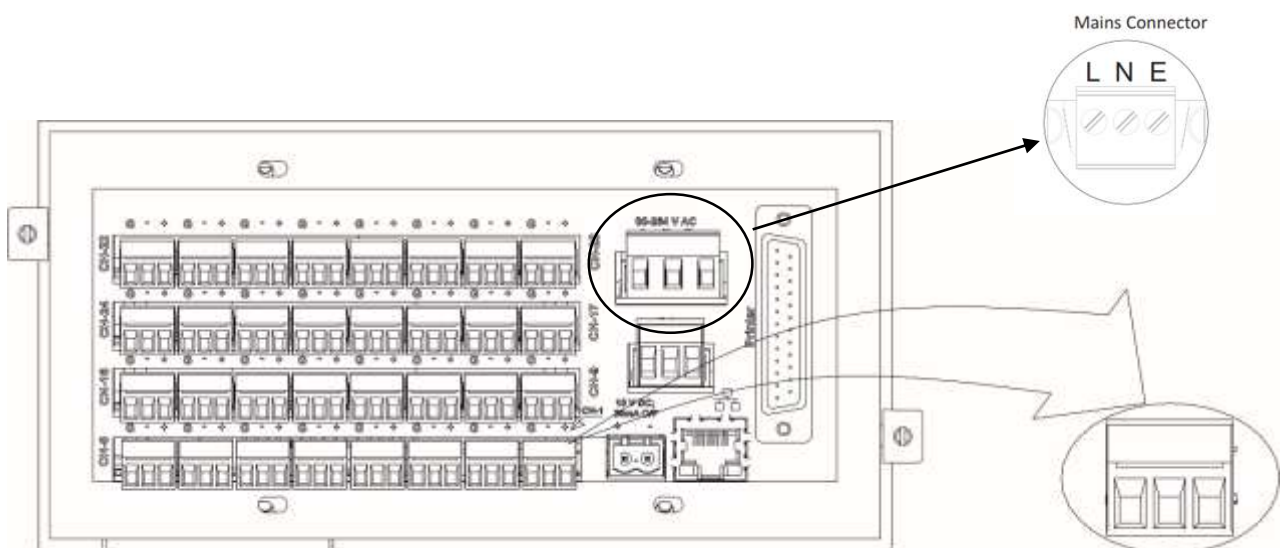

Figure 8 - Wiring Diagram for Scanner Series SC5x9x Pro

### 4.1.3 Mains Supply Connection

The connection for Mains supply is shown in figure 9. As per the figure the live, neutral & earth from the mains cord are connected to L, N & E, respectively. Ensure that the bared ends of the mains cord are fully inserted into the mains connector and no loose/poor connection.

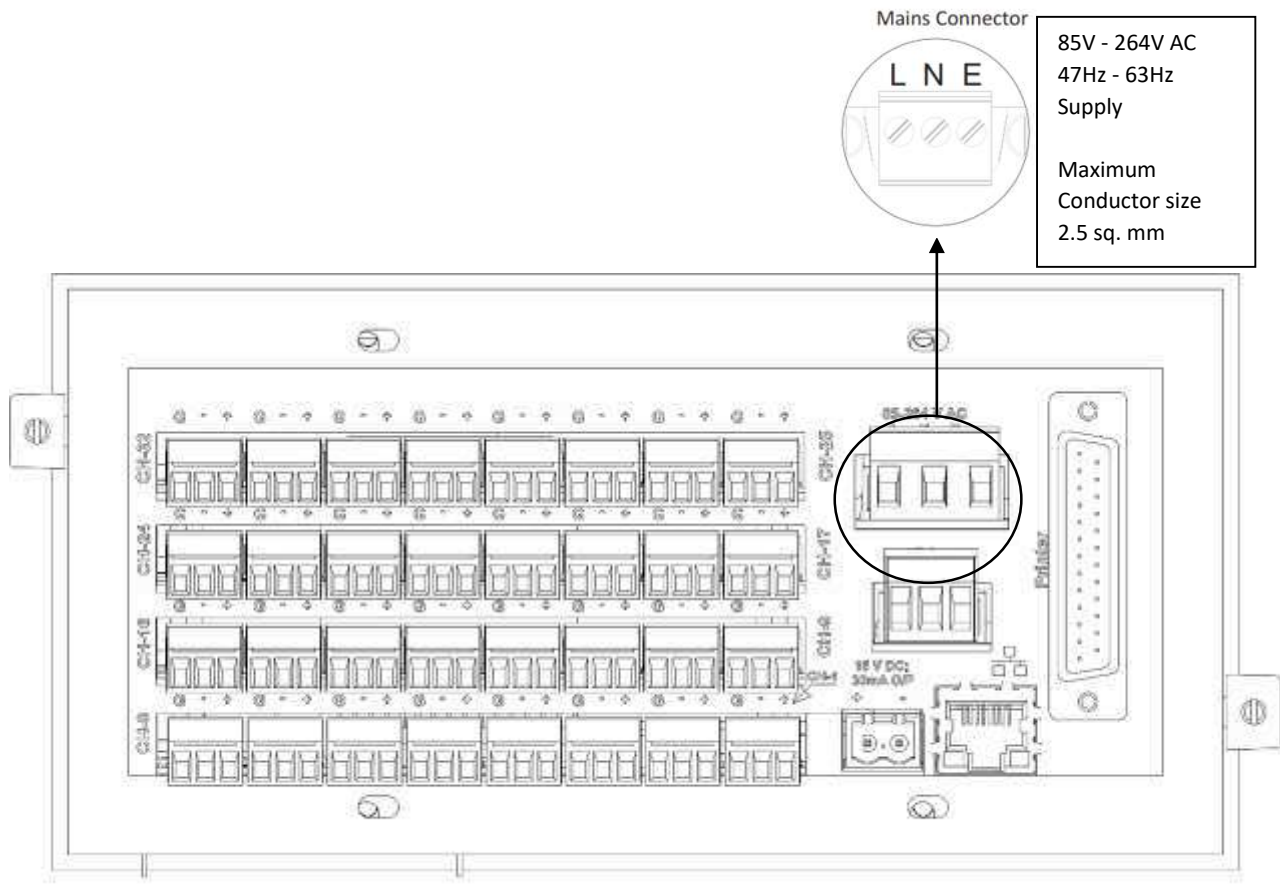

Figure 9 - Mains Supply Connection

#### 4.1.4 Sensor Wiring

To ensure maximum scanner performance, proper wiring installation practices must be followed. Failure to do so can result in a range of problems, from loss of configuration to component failure, caused by transmitted or radiated electrical noise. Proper consideration must be given to local noise sources and appropriate suppression steps taken to minimize any potential problems.

Among the most common sources of noise are: Relays, SCRs, valve solenoids, electric motors, power line disturbance, wire-to-wire coupling, electrostatic discharge (ESD) and radio-frequency interference (RFI).

1. To achieve the best results, the following notes should be considered:  
Low level signal wiring such as that associated with thermocouples, RTDs and current loops should always be kept separate from power and control output wiring.
2. Signal input wiring should be twisted pairs/triplets etc. and the conductors should be stranded rather than solid in construction. All signal wiring should use ground-shielded wires or be routed through grounded conduit. This minimizes the effects of RFI and ESD.
3. Care should be taken when wiring to relay or solenoid coils, as large transients are produced when coils (or any other inductive devices) are switched. This problem can be eliminated using suitable suppression devices across the coil. Coil transients can also be transmitted through the air, so the recorder itself should be mounted as far as possible from power control devices and/or wiring.
4. When line power is poorly regulated and / or subject to voltage surges or transients, consideration should be given to the use of a line conditioning/transient suppressing line power regulator. Process control motors, valves, relays, and heaters should not be connected to the same power lines that are used for instrumentation.
5. The connection of the Scanner to a proper safety earth ground is essential. Such a connection not only reduces the possibility of electric shock, but also provides the required return for the recorder line power filters.
6. All local electrical codes of practice must be followed when installing any instrumentation.

For sensor wiring, all the sensor connectors are at the back side of the scanner as shown in Figure 10.

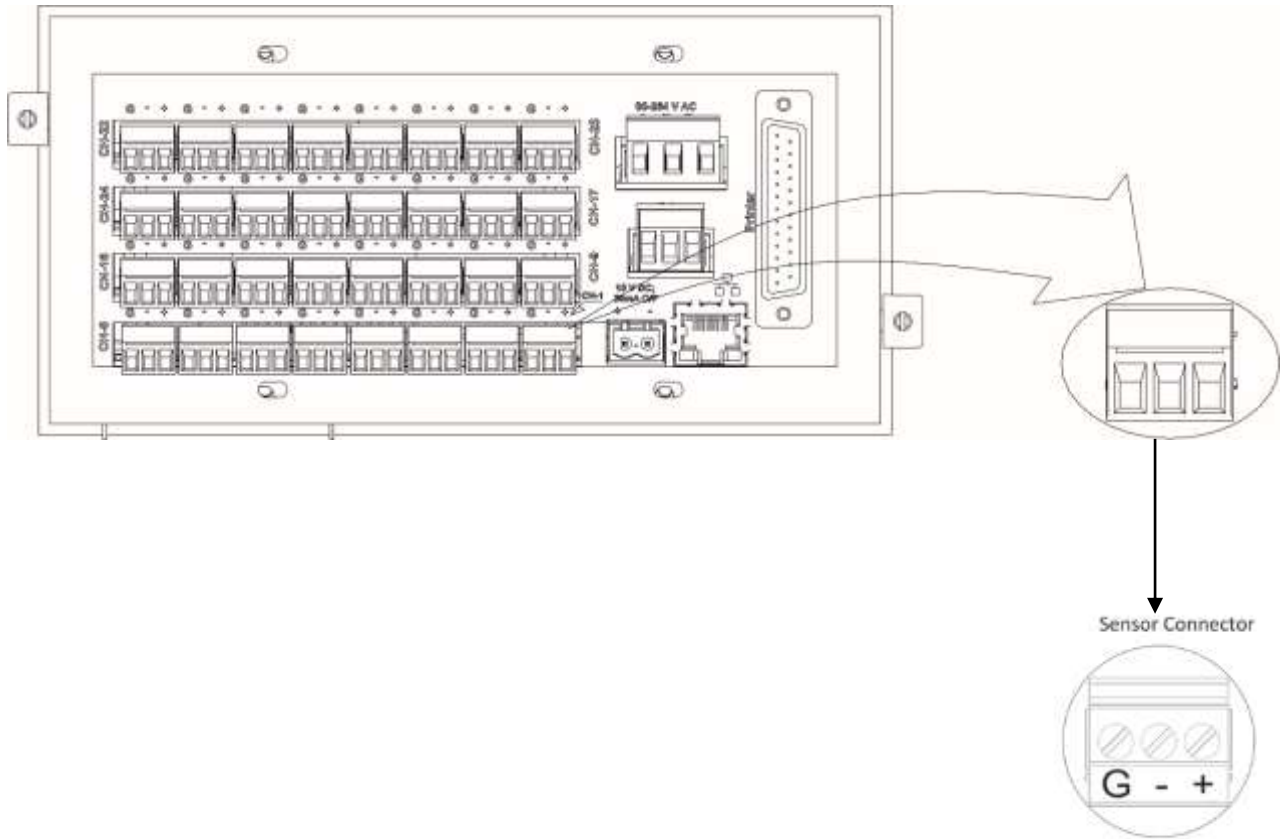

Figure 10 - Sensor Wiring

The Scanner can be connected and configured to operate with a variety of signal sources as thermocouple, RTD, DC current, DC voltage etc. The sensor wiring for different sensors is shown in following sections.

4.1.4.1 Sensor wiring - RTD (Pt-100) 3-wire input

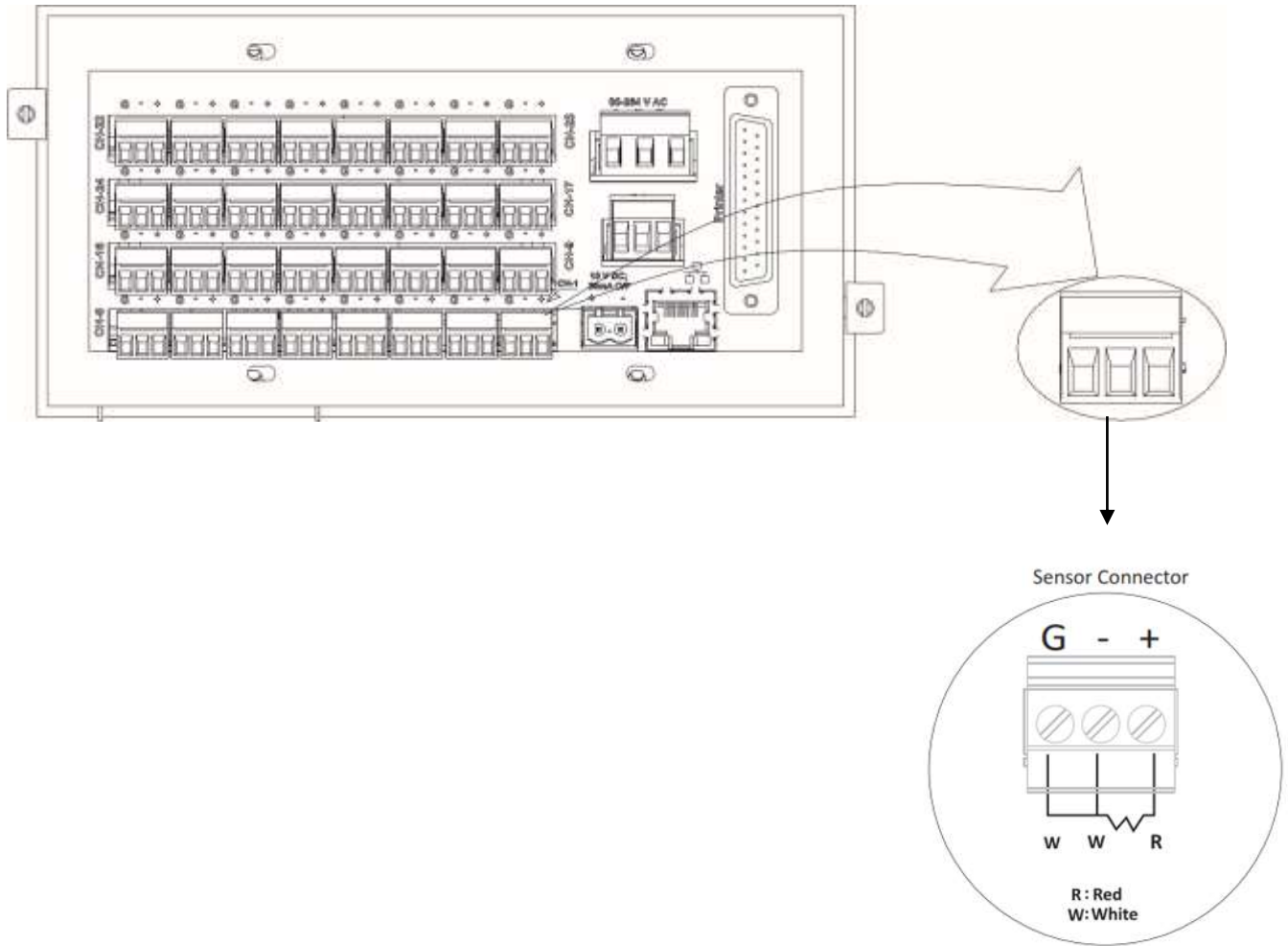

Figure 11 - Sensor Wiring - RTD (Pt-100) 3-Wire Input

The connection for 3-wire RTD (Pt-100) sensor is shown in figure 8. Normally RTD (Pt-100) sensor with 3-wires has two similar color wire and other one distinct color. Connect two similar color wires at '-' and 'G'. Connect the remaining dissimilar color wire at '+'. Similarly connect for another channel.

#### 4.1.4.2 Sensor wiring – RTD (Pt-100) 2-Wire Input

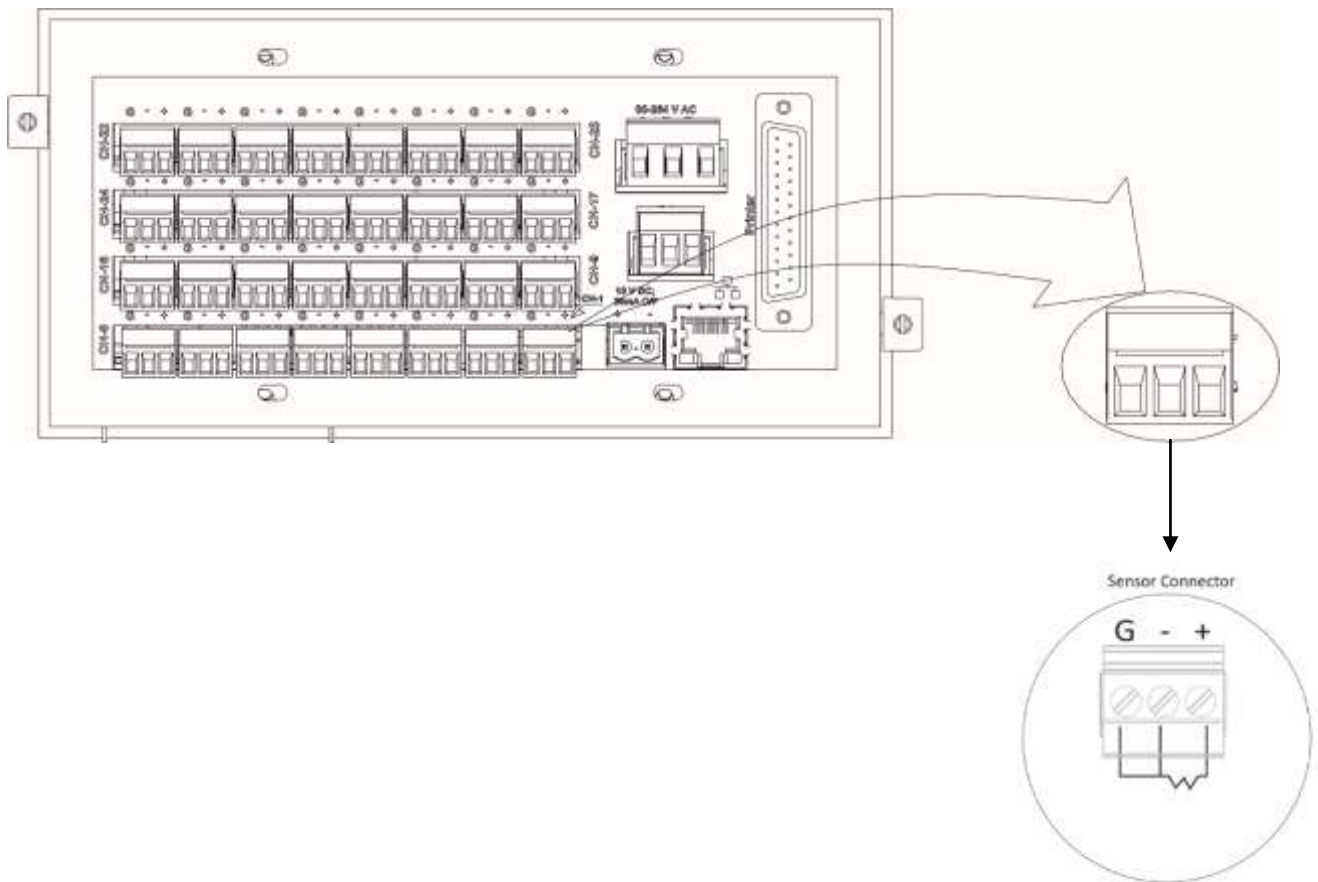

Figure 12 - Sensor Wiring - RTD (Pt-100) 2-Wire Input

For 2-wire RTD (Pt-100) sensor connects 2-wires of the sensor at '+' & '-' and put an external short link between '-' and 'G' as shown in figure 12. Similarly connect for all other channels.

#### Notes:

1. When wiring RTDs, lead length and diameter must be chosen such that lead length are equal and that each lead exhibits no more than 10Ω resistance between the scanner and the RTD (Pt-100).
2. For Input connections, high quality, low resistance contacts must be used which are suitable for dry operations.

#### 4.1.4.3 Sensor wiring - thermocouple Input

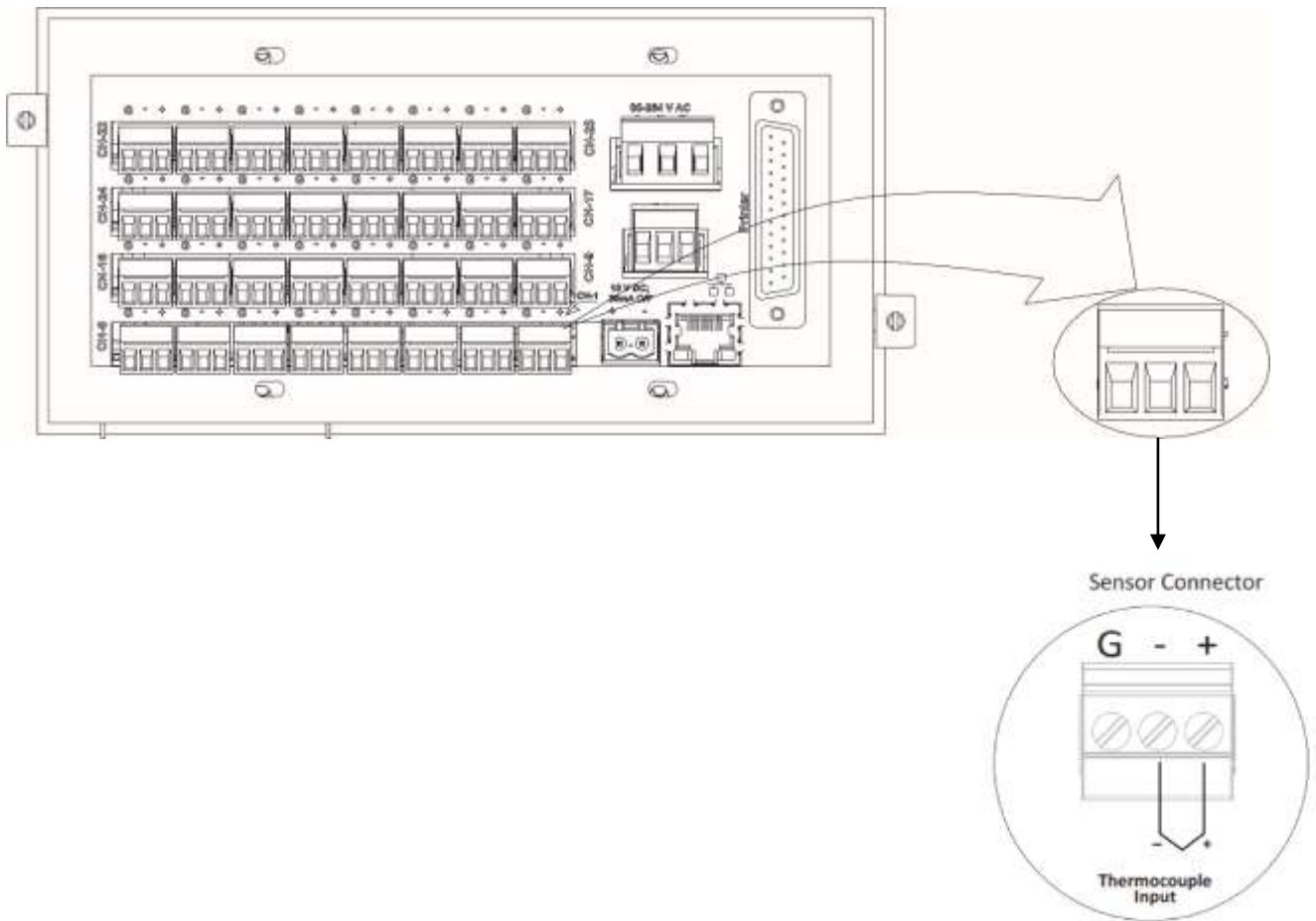

Figure 13 - Sensor Wiring - Thermocouple Input

Connect the 2-wires of Thermocouple sensor at '+' & '-' of sensor connector as shown in Figure 13.

**NOTE:** If thermocouple reading fluctuates then apply short link in between "-" and "GND".

#### 4.1.4.4 Sensor wiring - Volt input

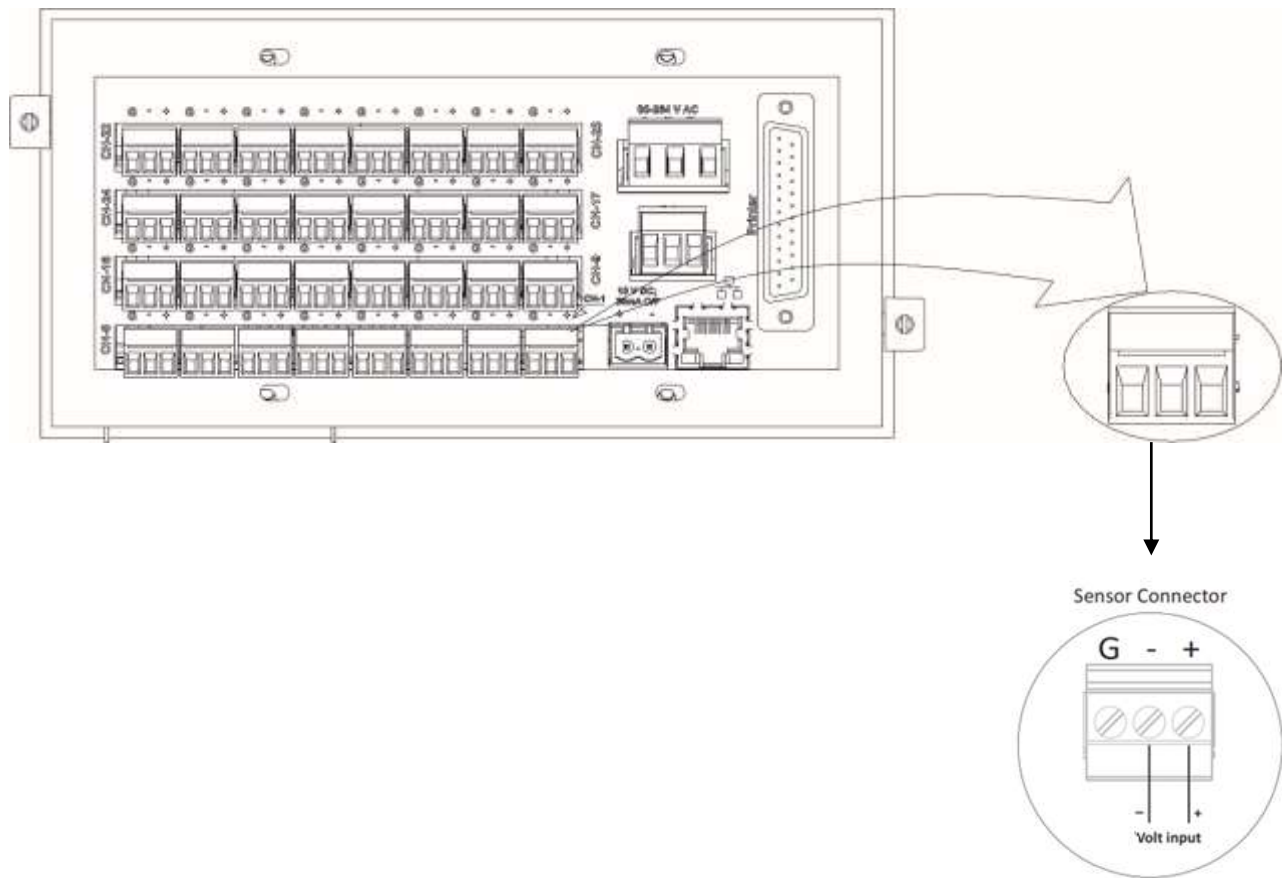

Figure 14 - Sensor Wiring – Volt Input

The Sensor connection for Volt input is shown in figure 14. Connect the '+' and '-' of the sensor to '+' and '-' respectively of sensor connector as shown in Figure 10. Similarly connect for all other channels.

4.1.4.5 Sensor wiring - 4-20mA / 0-20mA Input

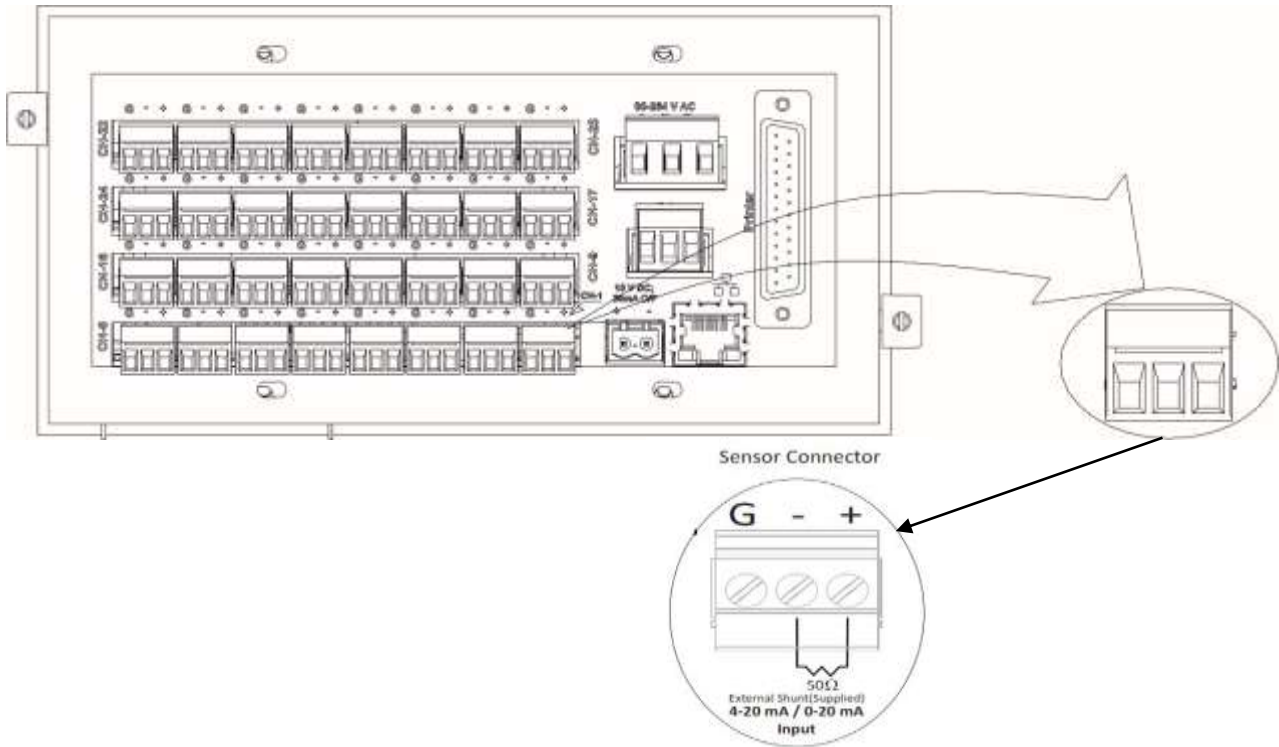

Figure 15(A)

Connecting Scanner and other instrument in series with Transmitter and External Power Supply

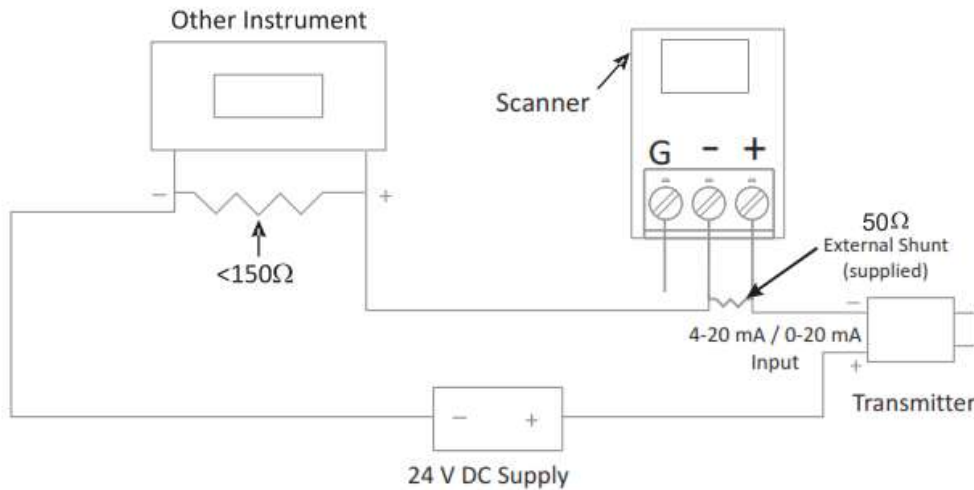

Figure 15 (B)

Figure 15 - Sensor Wiring - 4-20mA / 0-20mA Input

The connection for 4-20mA / 0-20mA input is shown in the figure 15(A). For Scanner, the shunt of 50Ω 0.1% is externally supplied. If you want to connect more than one instrument in series, than scanner should be placed in such a way that not more than 150Ω of load resistance is added in the loop after scanner as shown in Figure 15(B).

**Note:** - If 50Ω 0.1% shunt is used than the user must keep the multiplier as 1.008 approximately for 4-20mA and as 1.003 approximately for 0-20mA.

#### 4.1.5 Connecting Scanner with Transmitter and External Power Supply

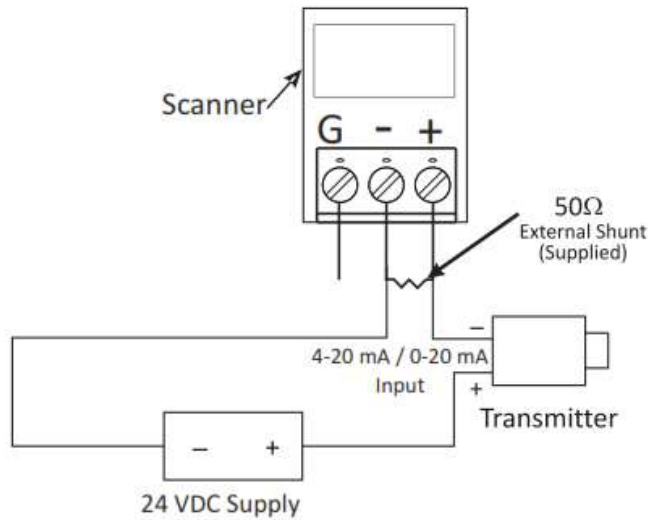

\* If required, put link between '-' & 'G'.

Figure 16 - Connecting Scanner with Transmitter and External Power Supply

Connection of Scanner with Transmitter and External Power Supply is as shown in Figure 16. For Scanner, the shunt of 50Ω is externally supplied.

#### 4.1.6 Wiring Diagram for Relay Connection

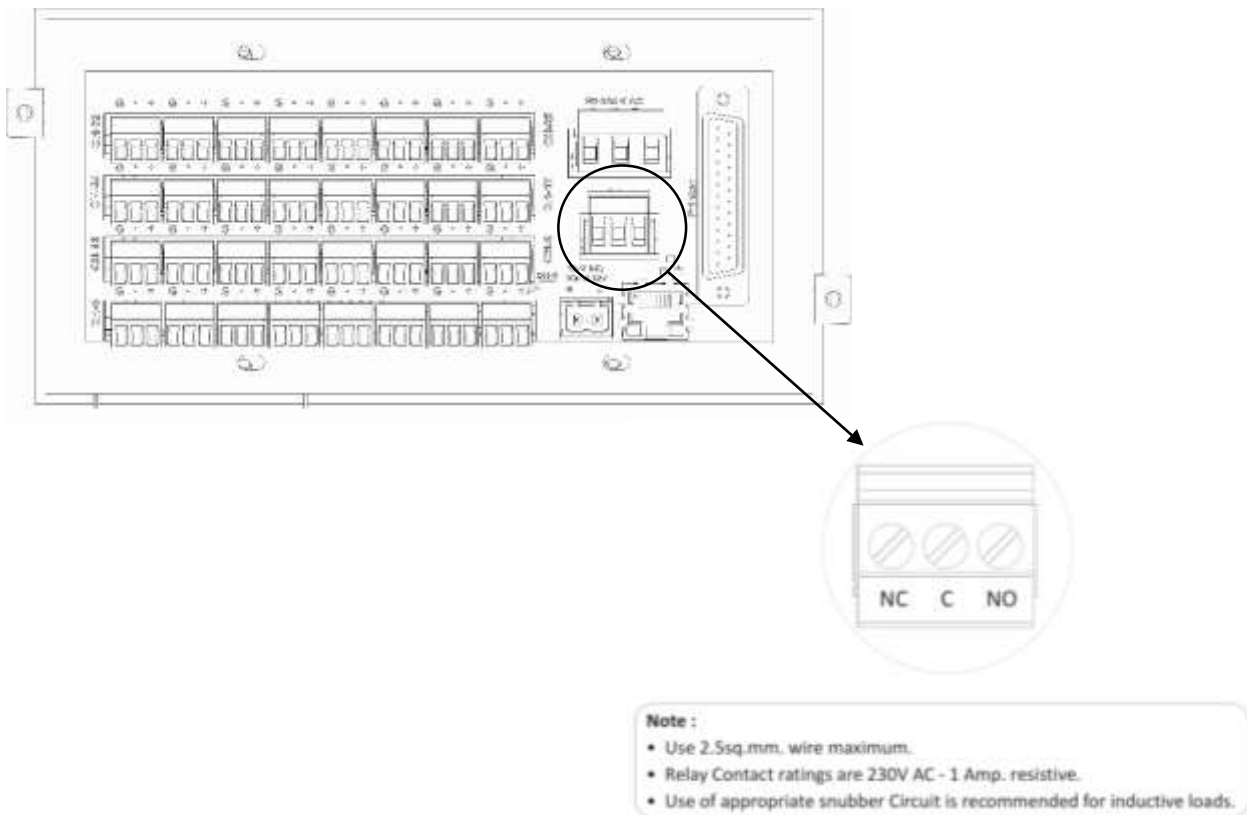

Figure 17 - Wiring Details for Relay Connections

### 4.1.7 Wiring diagram for PC interface

The Scanner can relate to PC using TCP/IP Interface through GtekNet software developed by G-Tek. For this, RJ-45 connector is given on the back panel of the scanner. A Crossover TCP/IP Cable is required to connect Sc5x9x Pro device to LAN. The cable wiring for crossover cable is shown in figure 18.

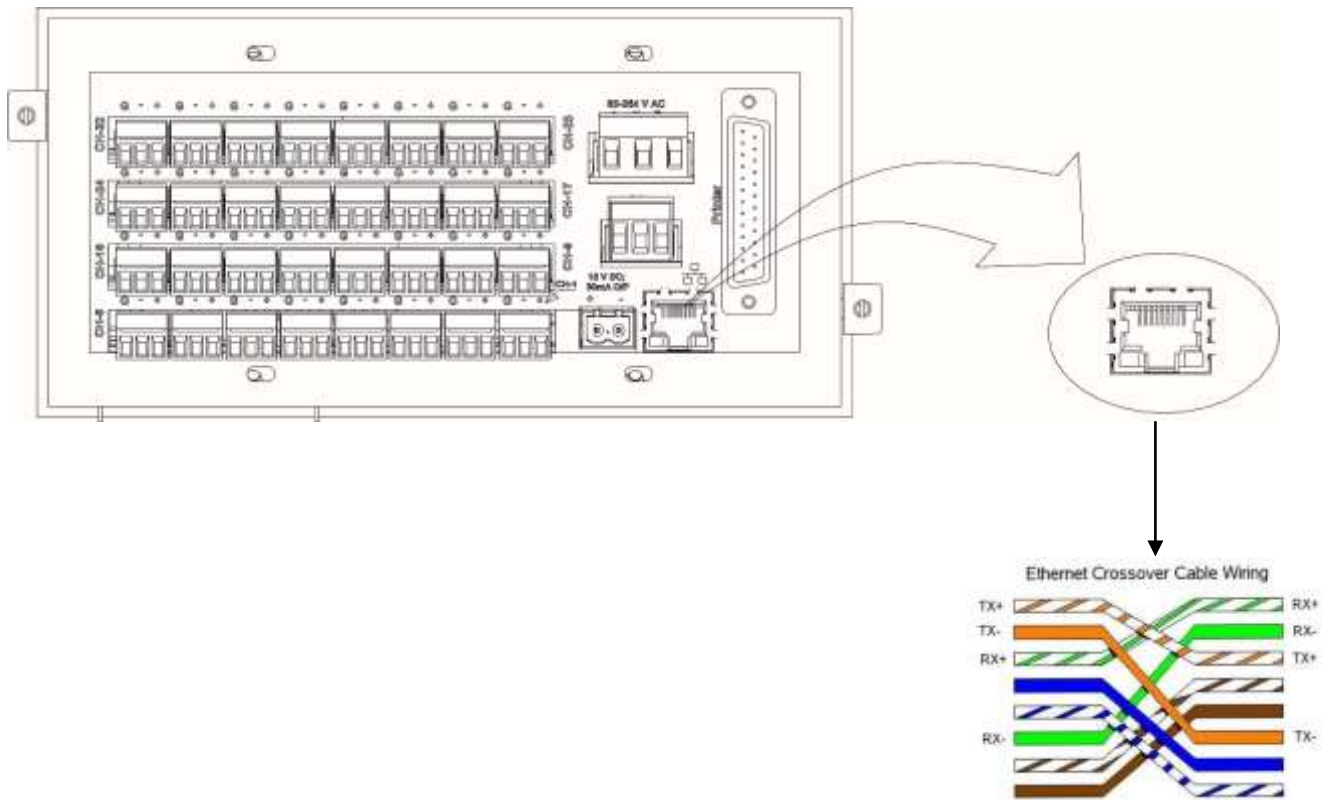

Figure 18 - Wiring Details for Ethernet Connections

## 5 OPERATION

After the proper wiring is done, power on the Scanner. The display will show “G-Tek Corporation”. Following this, the parameter values of channel 1 to 4 is displayed on the right along with its unit, with the channel number on the left & it continue for the group of next 4 channels. If the batch is not running, then parameters of previously stored data will be taken as configuration, but the storage & printing will not start. To start the storage and online printing, user must start the online batch on the scanner. If the batch is previously running and is not stopped, then after power up the batch will continue to run and online storage & printing will resume. User can reconfigure the parameters here by going into programming(configuration) menu (Refer Programming section).

The Scanner front panel consist of LCD display, keyboard, USB slot and status indication LEDs as shown in figure 19.

### Front Panel:

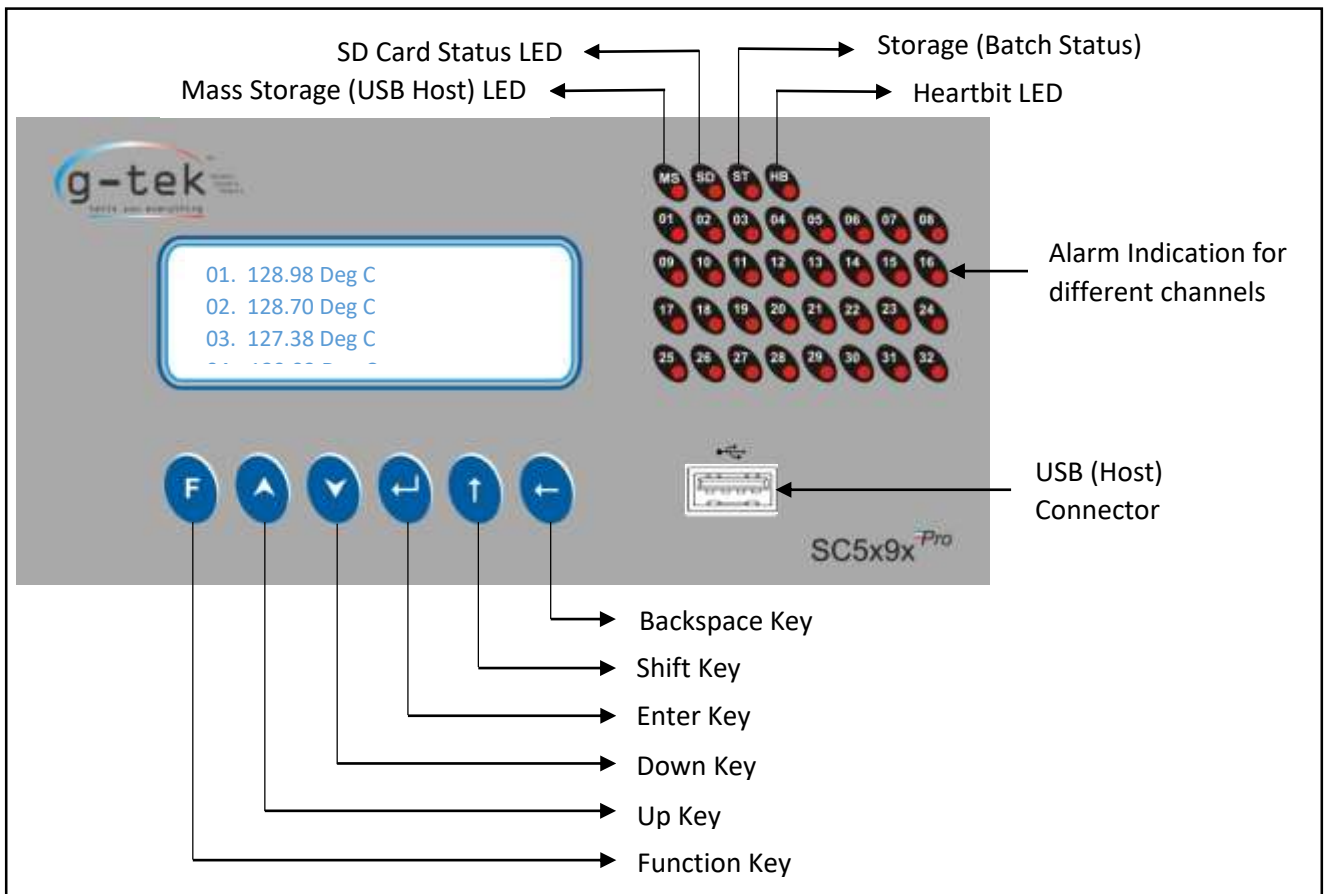









Figure 19 - Front Panel

### Character Set:

The available Character set are A to Z, a to z, 0 to 9 and some other special characters like -, @, !, %, #, ", etc.

### Keys:

There are four multifunction keys are available on the front panel of the scanner to configure the different parameters. The function of these keys is described as below:

-  Function key is used to enter the main menu sequence as well as come out from the submenus or the main menu to default display.
-  Up key is used to **increment the parameter value**. It only increases the value or go into the previous menu/submenu.
-  Down key is used to **decrement parameter value**. It only decreases the value or go into next menu. In case of the Channel On/Skip menu this key is used to toggle the status of that channel.
-  Enter key is used to **save the parameter values**, to enter a menu/submenu.
-  Shift key is used to **shift cursor** right by one position or used to IP reset.
-  Back key is used to return from the submenu.
-   **Down + Back** - This key combination is used to Acknowledge alarm.

### LED Indication:

**Channel LEDs:** These LEDs are provided on the front panel for Alarm indication of their respective channel number. If the channel value exceeds SPH or goes below SPL than the LED of that channel will turn ON.

**Storage (ST):** This LED shows Batch start indication, which means the device has started collecting data. It will blink every 1 sec if the batch is started.









**SD Card (SD):** If SD Card is present in the datalogger then the SD LED will turn ON.

**Mass Storage (MS):** If USB Device is present in the datalogger then Mass Storage LED will turn ON.

**Heartbeat (HB):** This LED shows Device Status. If the device is working perfectly than this LED will blink every 1 sec.

## 6 SCANNER CONFIGURATION

### Usage of Keys:

-  Function key is used to enter the main menu sequence as well as come out from the submenus or the main menu to default display.
-  Up key is used to **increment the parameter value**. It only increases the value or go into the previous menu/submenu.
-  Down key is used to **decrement parameter value**. It only decreases the value or go into next menu. In case of the Channel On/Skip menu this key is used to toggle the status of that channel.
-  Enter key is used to **save the parameter values**, to enter a menu/submenu.
-  Shift key is used to **shift cursor** right by one position or used to IP reset.
-  Back key is used to return from the submenu.
-   **Down + Back** - This key combination is used to Acknowledge alarm.

### • Configurable Item:

Sensor Type	Type of sensors which can be connected. 1. RTD (Pt-100) 2. TC - J 3. TC - K 4. TC - R 5. TC - S 6. TC - T 7. TC - E 8. TC - N 9. 4-20mA 10. 0-20mA 11. Unipolar 1V 12. Bipolar 1V 13. Unipolar 5V 14. Bipolar 5V
Batch Start/Stop	Control to start a new batch and stop a running batch
Batch Name	Configure 8 Char length batch name excluding all special chars
Batch Start Time	Set a future time to start the batch automatically
Printer Use	Enable or Disable printing
Print Interval	Interval of data printing
Printing Types	1. Print if batch is On 2. Always printing
Print CH Config	Option to configure whether the user wants to print channel configuration or not.
Printer Header and Footer	User can set the header and footer of the page from this menu option. There are two headers and two footers. Each of the Header and footer will be 40 char length. Each header and footer are divided in two parts e.g., Header 1(a), Header 1(b) & Header 2(a) and Header 2(b), Similarly for footer.

No. of Lines per page	User can set no. of lines to be print on a single page. User can set no. of lines in the range of 1 to 32767.
Dump start time	User can select start time from where batch data should be printed.
Dump stop time	User can select stop time up to which batch data should be printed.
Dump to print	User can select which batch file should be printed. There are 2 options available 1.Last Batch 2.Selected time
Print page no.	User can select whether page no. should be printed or not. User can set "Yes" if page no. should be printed and set "No" if page no. should not be printed.
Display setting	1. Freeze or unfreeze a channel on default display 2. You can set channel data display along with unit or not 3. Configure display rolling time
Restore CH Param	Not Implemented
Restore Calibration	Not Implemented
Set Date and Time	Set internal real-time clock of Scanner when the batch is off.
Skip Channel	Skip a channel from scanning.
Store Interval	Time interval at which the data will be stored.
Range Low	The minimum value to be displayed when process inputs like 0V to 1V, -1V to +1V, 0V to 5V, -5V to +5V, 0mA to 20mA & 4mA to 20mA are at the lowest value.
Span	The difference between maximum & minimum value used for process inputs.
Offset	A small correction may be required when actual sensor is connected to the Scanner. This is a mathematical value which is directly added to the reading.
Multiplier	A value to remove any scale error. This is a mathematical value which is directly multiplied to the reading. <b>Displayed reading = (reading x multiplier) + offset</b>
Resolution	Configure the smallest value the datalogger can detect and display in terms of decimal places.
Alarm set point High (SPH)	The upper limit of value, after which alarm is generated
Alarm set point Low (SPL)	The lower limit of value, after which alarm is generated
Unit	A quantity generally accepted as a standard e.g., DEG C, %RH etc. The maximum length of a unit is 10 characters.
Tag	A user defined name to a particular channel e.g., "CH 1". The maximum length of a Tag is 10 characters.

## 6.1 PROGRAMMING(CONFIGURATION) SEQUENCE

The Scanner can be Configured using front panel Keyboard. The following figure shows the main menu sequence:

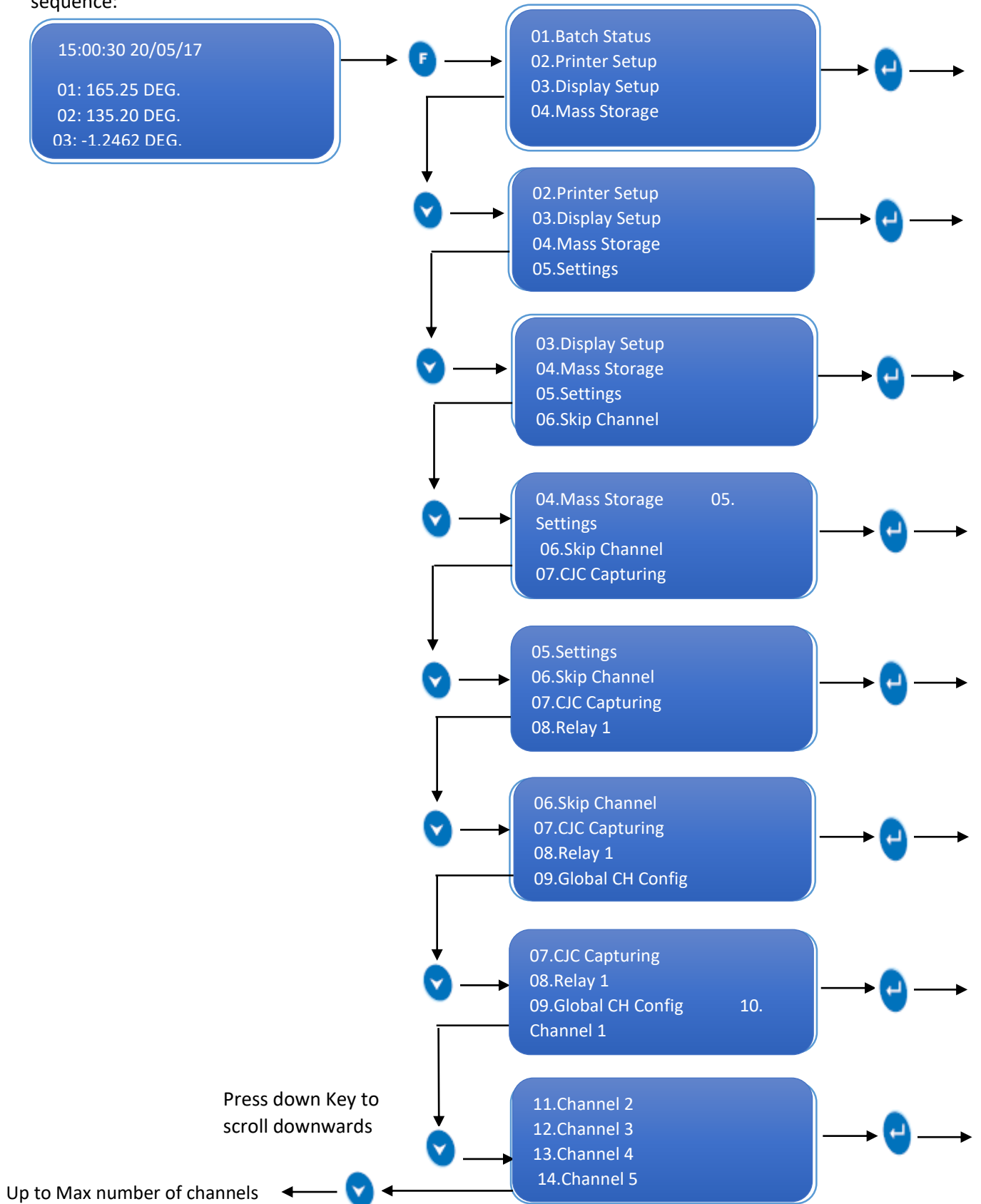





## 6.2 BATCH STATUS

This Menu Includes following submenu options:

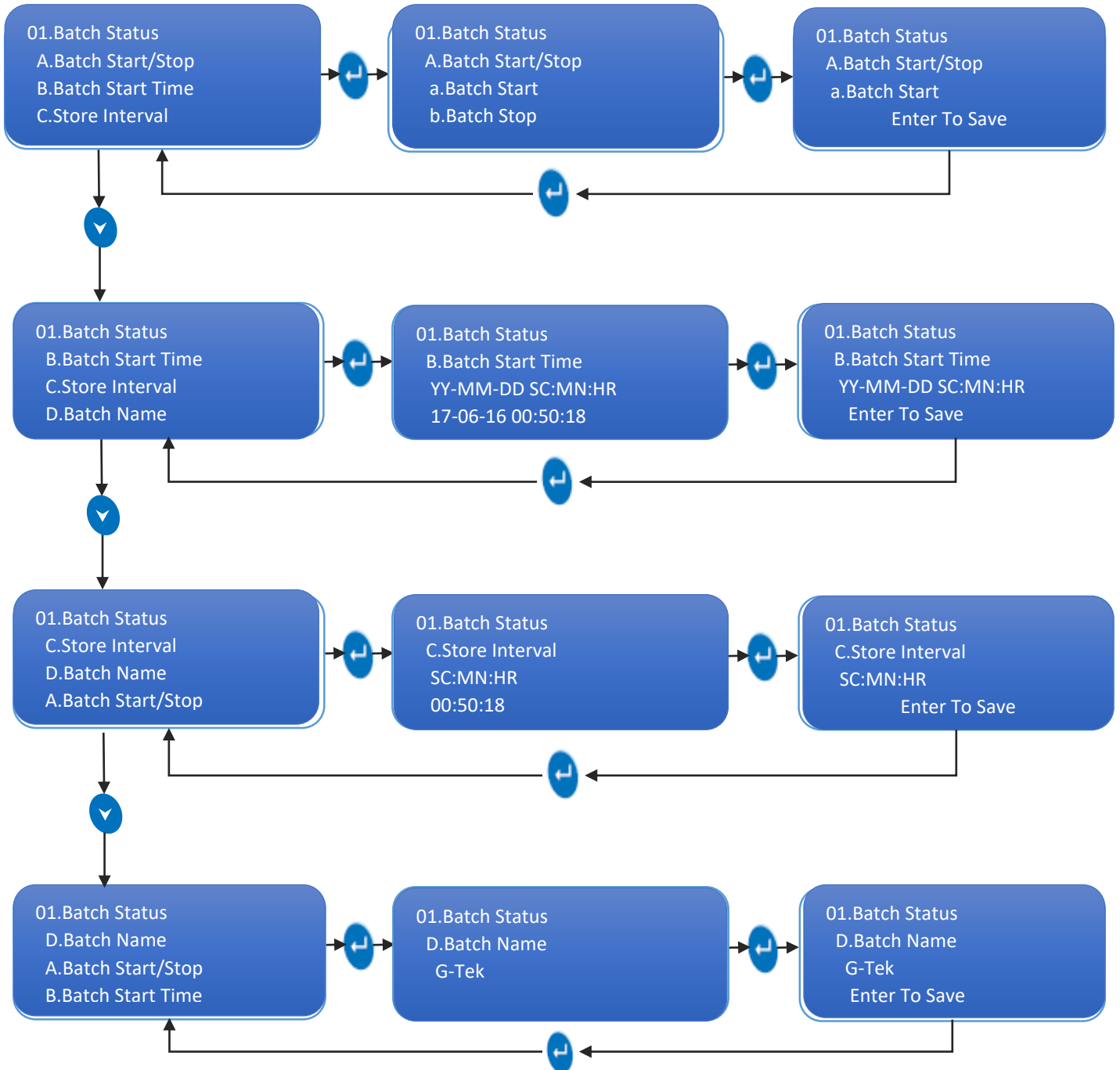
1. Batch Start/Stop Control
2. Batch Start Time for pre-config batch
3. Store Interval
4. Batch Name

To operate above mentioned submenus, follow procedure mentioned below in graphical form:



**Note:** - 1) Use  or  Key to Increment/Decrement parameter Values or to scroll up or down.  
 2) Use  Key to shift cursor Right by One Position to Enter Batch Name.

### 6.2.1 Batch Start/Stop

Batch start and stop procedure is shown in graphical form below.

**Batch Start Procedure:**

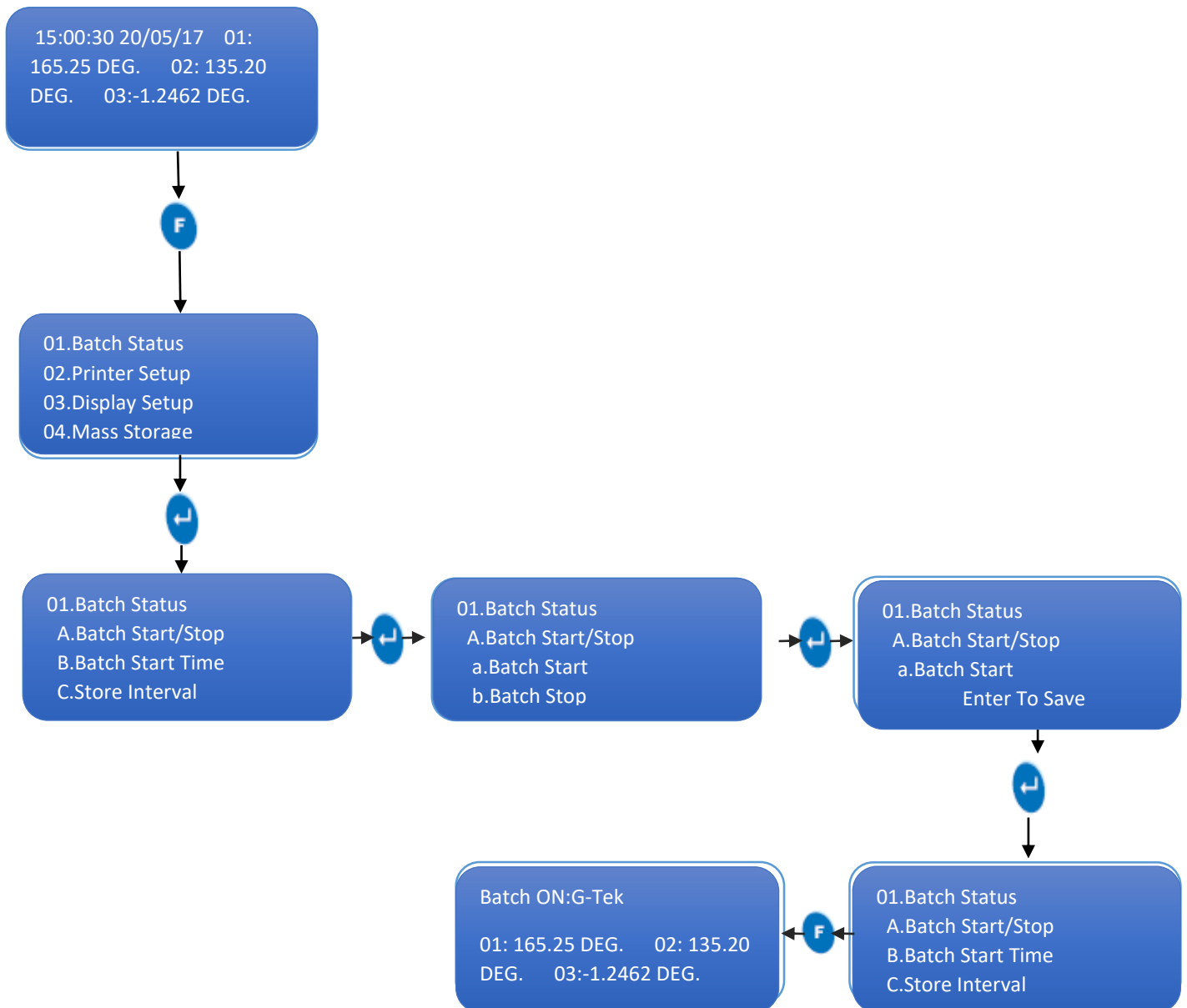

**Note:** - After the batch is started, when the user presses Function key, “Batch On: *Batch Name*” message will appear on default display.

**Batch Stop Procedure:**

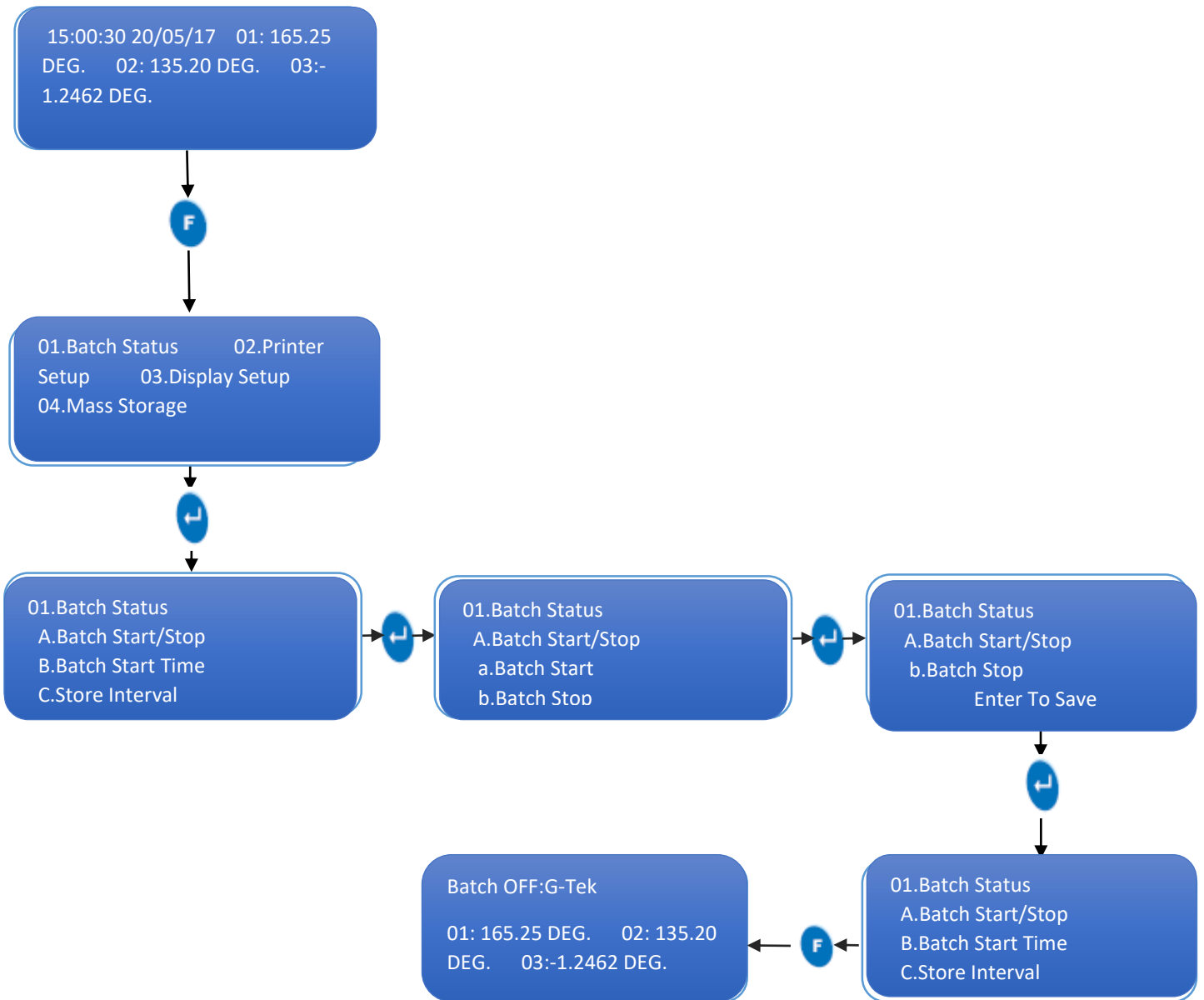

**Note:** - After the batch is stopped, when the user presses Function key, “Batch OFF: *Batch Name*” message will appear on default display.

### 6.3 PRINTER SETUP

This Menu Includes following options:

1. Use Printer
2. Print Interval
3. Printing Type
4. Print Channel Config
5. Header
6. Footer

To operate above mentioned submenus, follow procedure mentioned below in graphical form:

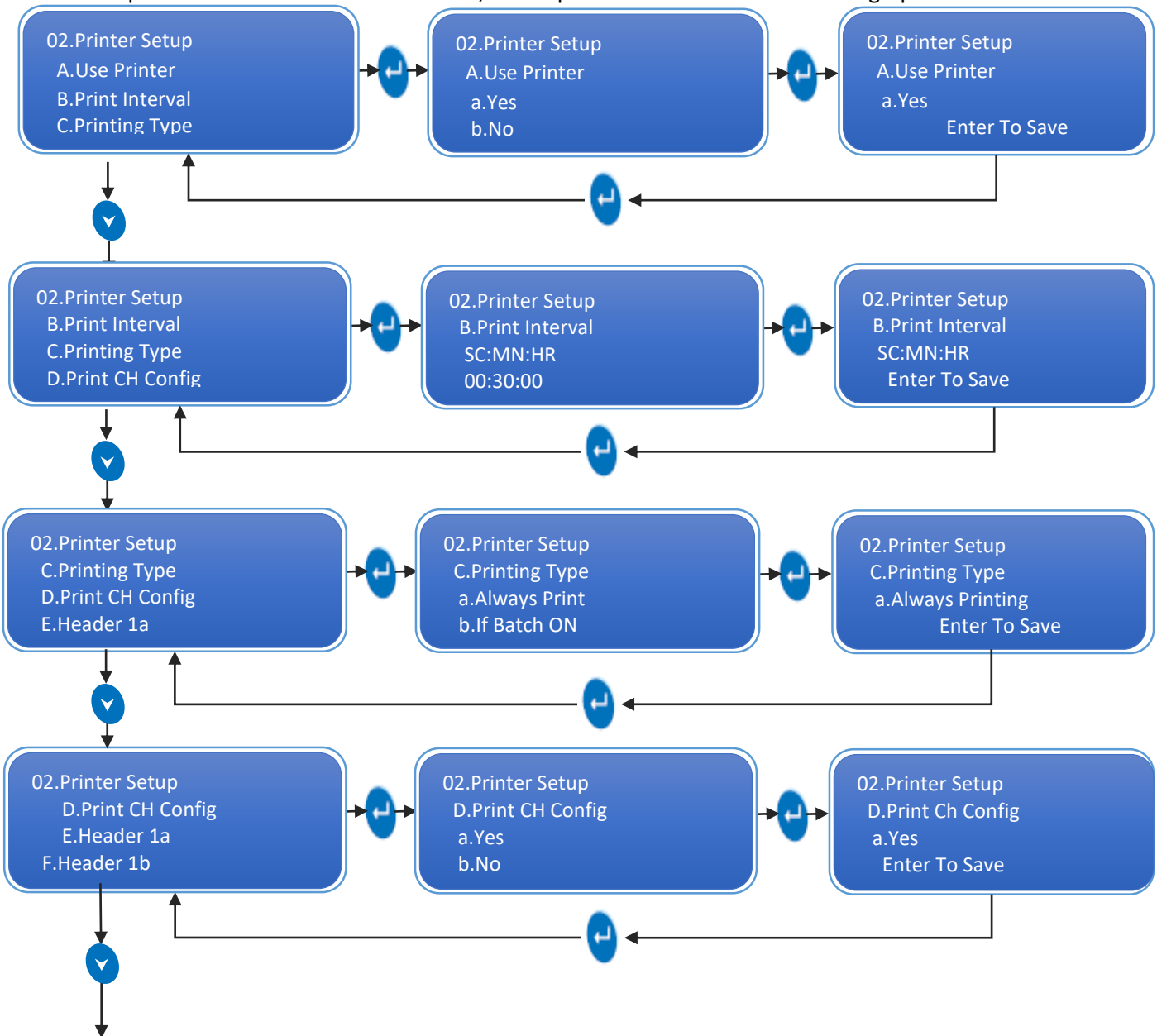

**Note:** - Print Interval should be at least 1 minute.

**Note:** - Use Shift Key to move cursor right and use Up Key and Down Key to change characters.

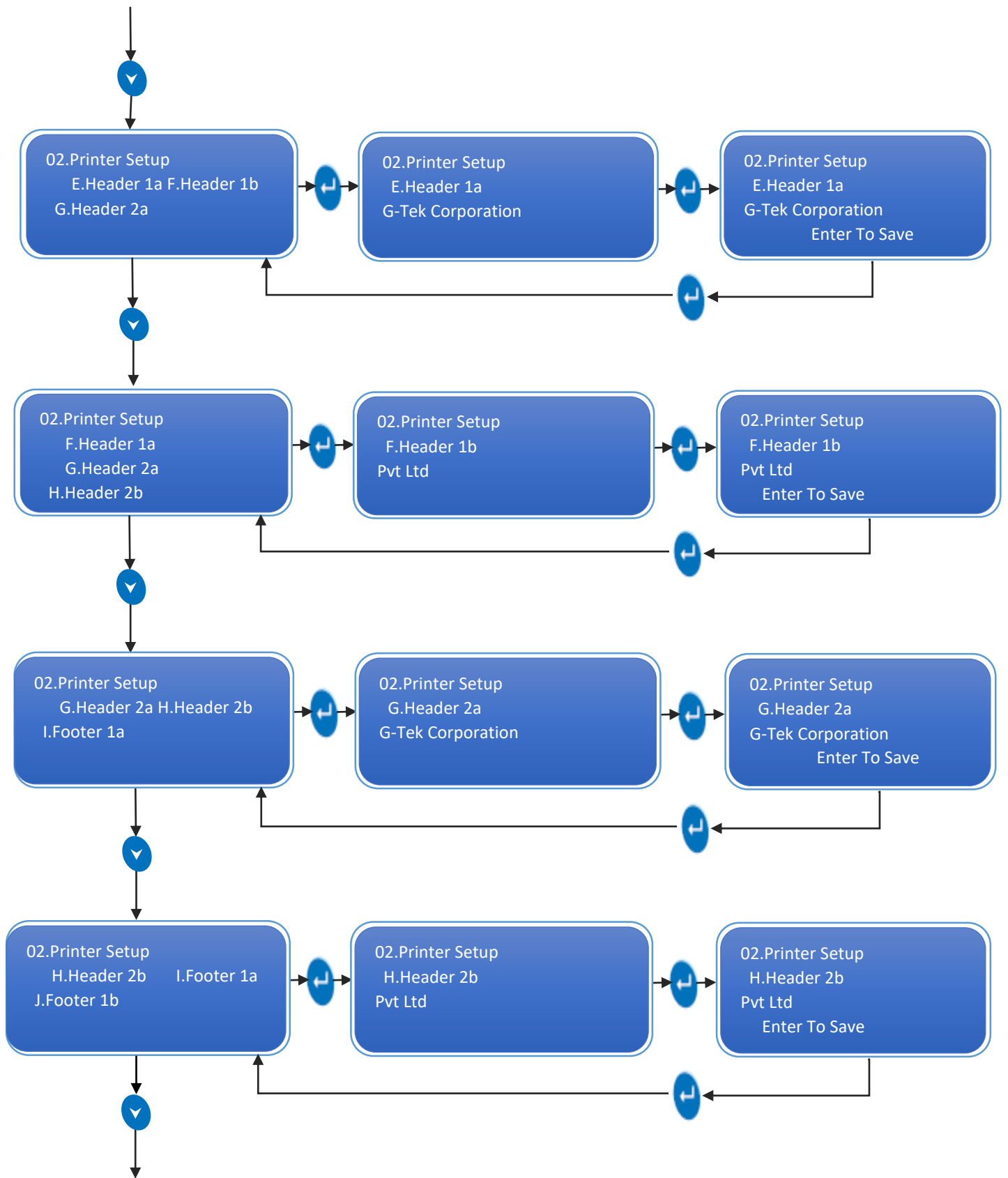

**Note:** - Use Shift Key to move cursor right and use Up Key and Down Key to change characters.

**Note:** - User can only write 40 Characters in Header 1 (20 in Header 1a and 20 in Header 1b) and 40 characters in Header 2 (20 in Header 2a and 20 in Header 2b)

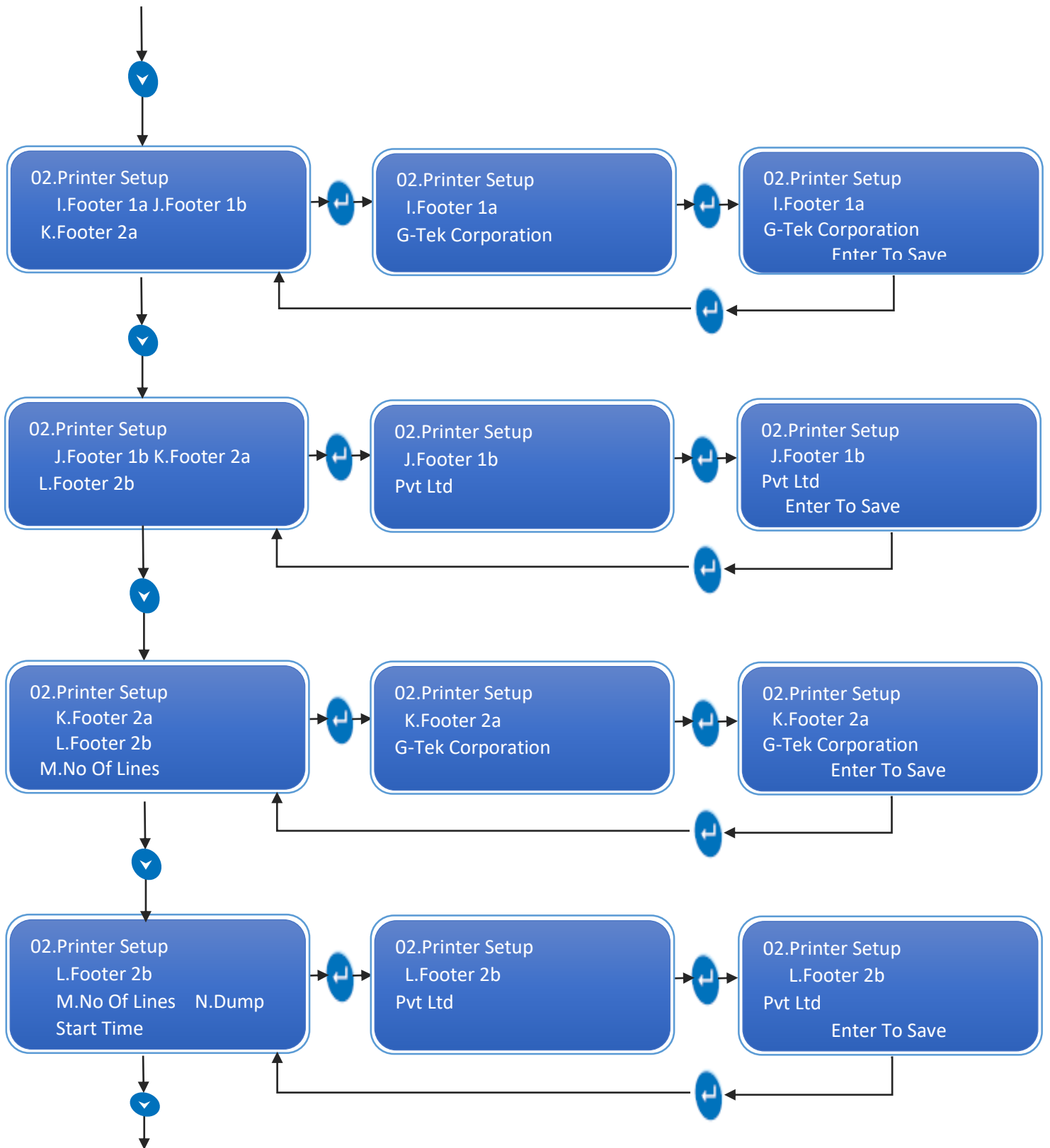

**Note:** - Use Shift Key to move cursor right and use Up Key and Down Key to change characters.

**Note:** - User can only write 40 Characters in Footer 1 (20 in Footer 1a and 20 in Footer 1b) and 40 characters in Footer 2 (20 in Footer 2a and 20 in Footer 2b)

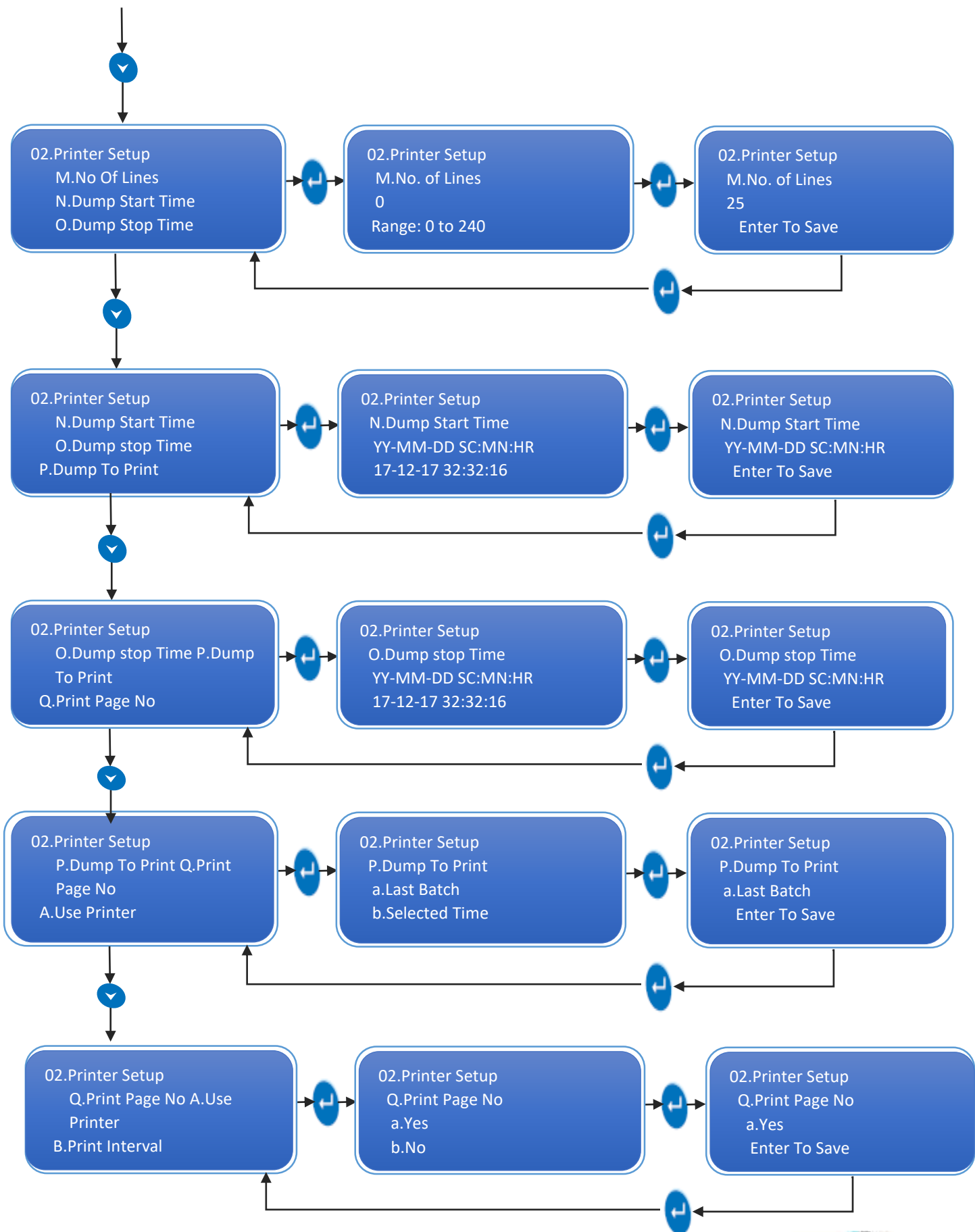



## 6.4 DISPLAY SETUP

This Menu Includes following options:

1. Display Unit
2. Channel Rolling Time
3. Freeze RTC
4. Freeze Channel *Number*

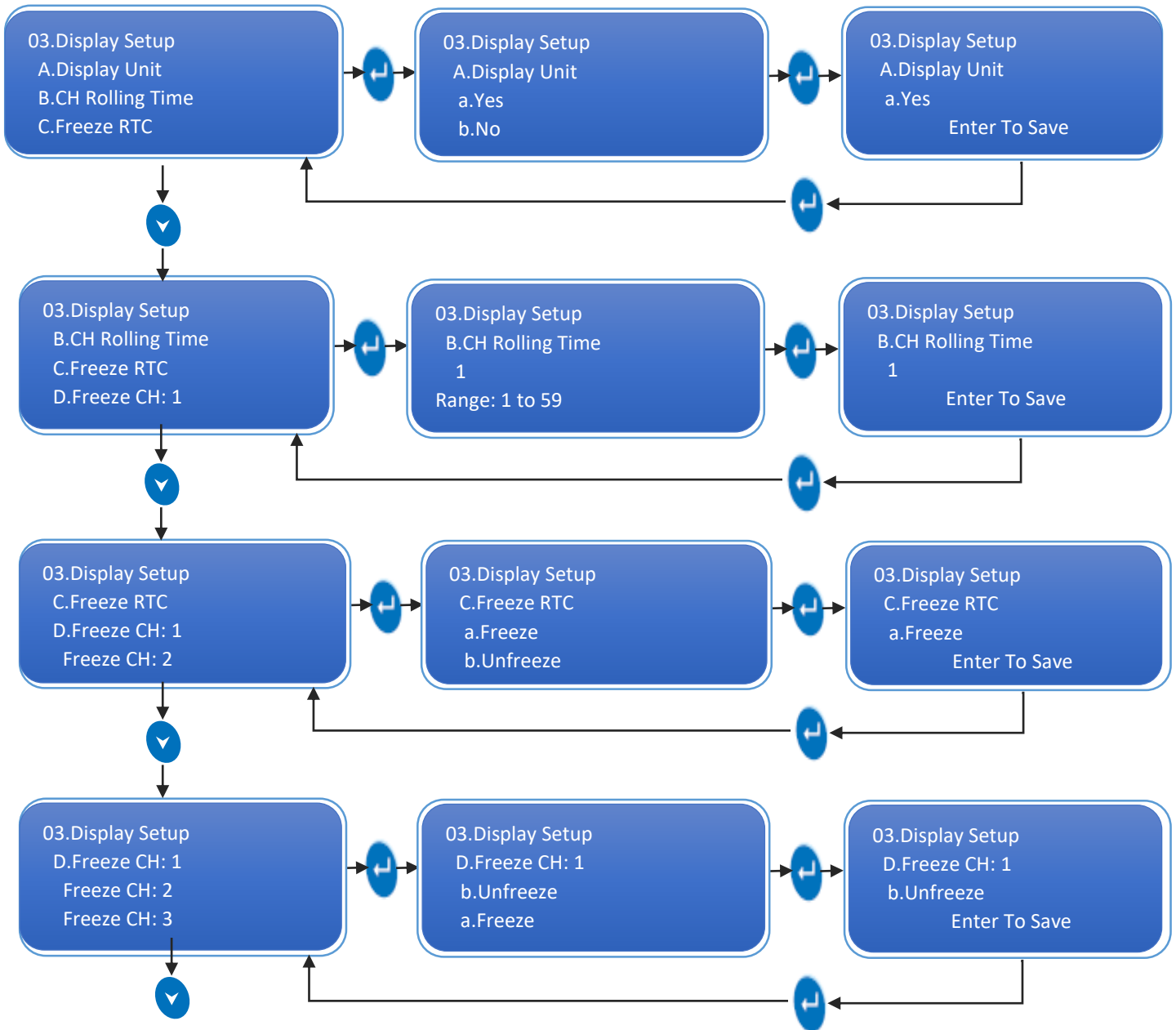
To operate above mentioned submenus, follow procedure mentioned below in graphical form:



**Note:** - Press  Key to Freeze/Unfreeze Channel up to Max Channel.

**Note:** - Use Shift Key to move cursor right and use Up Key and Down Key to change characters.

### 6.4.1 Display Unit

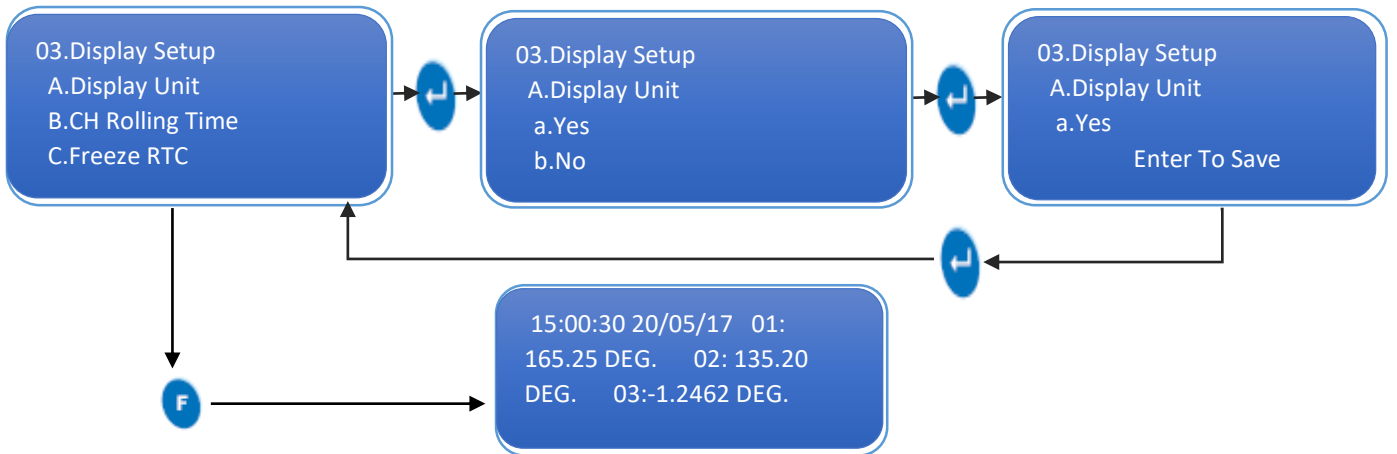

If the user wants to display channel unit along with the channel reading than select YES in Display Unit submenu. So, the display will show one channel reading in one line.

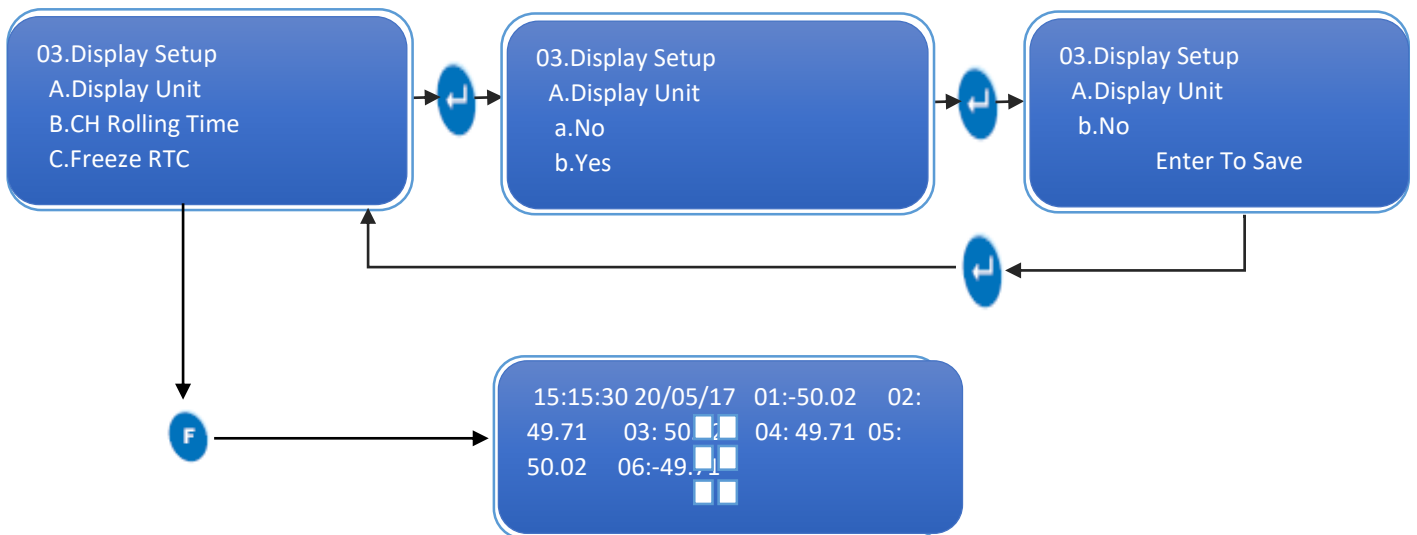

If the user does not want to display channel unit along with the channel reading than select NO in Display Unit submenu. So, the display will show two channels reading in one line as shown above.

## 6.5 MASS STORAGE

There are two kinds of mass storage devices which are supported by Sc5x9x Pro data logger.

1. SD Card
2. USB Host Device

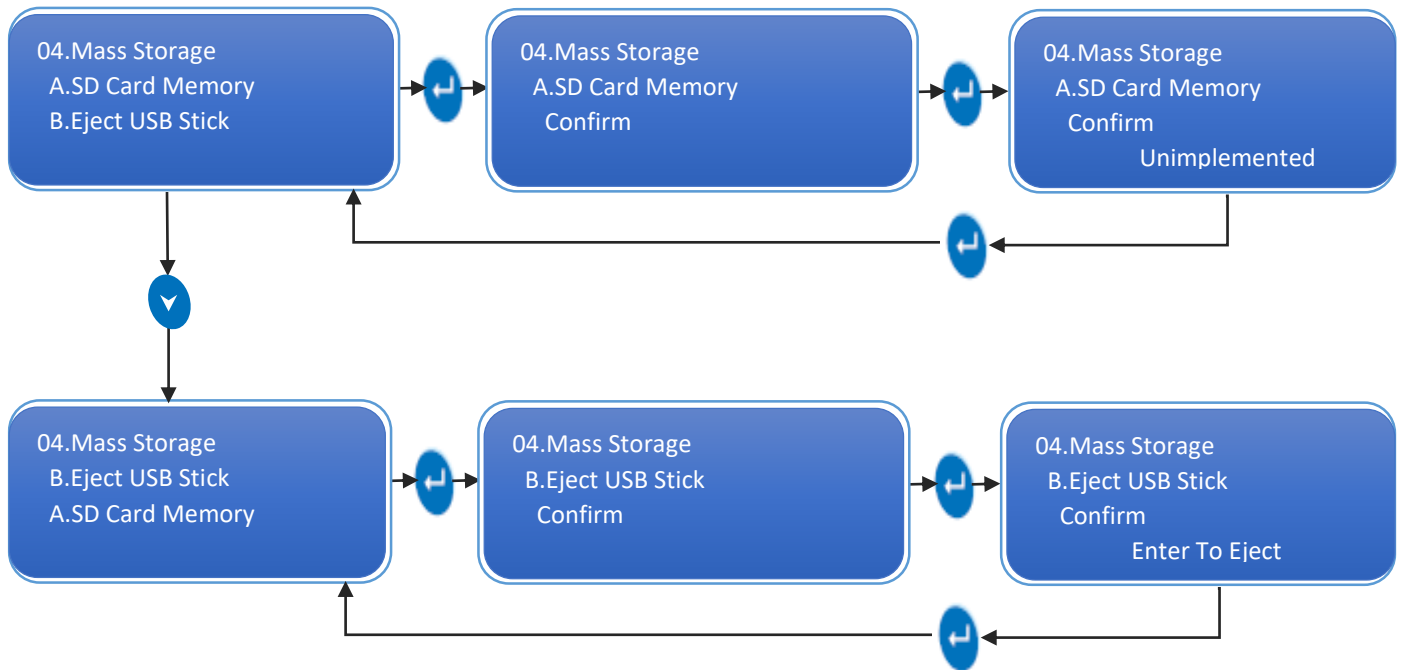

User is advised not to remove the SD Card from the data logger to avoid data loss. And it is recommended to use SD Card provided from the factory.

To remove USB stick from the data logger, the user must eject the USB Stick first from the mass storage menu as shown above.

## 6.6 SETTINGS

In settings menu, we can restore channel parameters (e.g., Sensor type, range low, span, offset multiplier etc.) & restore calibrations (factory calibration). We can also set time and date of system in this menu.

The restore channel parameter menu option will overwrite current channel parameter to predefined parameters saved in the memory.

The user will require a password to restore channel parameters and factory calibration parameters.

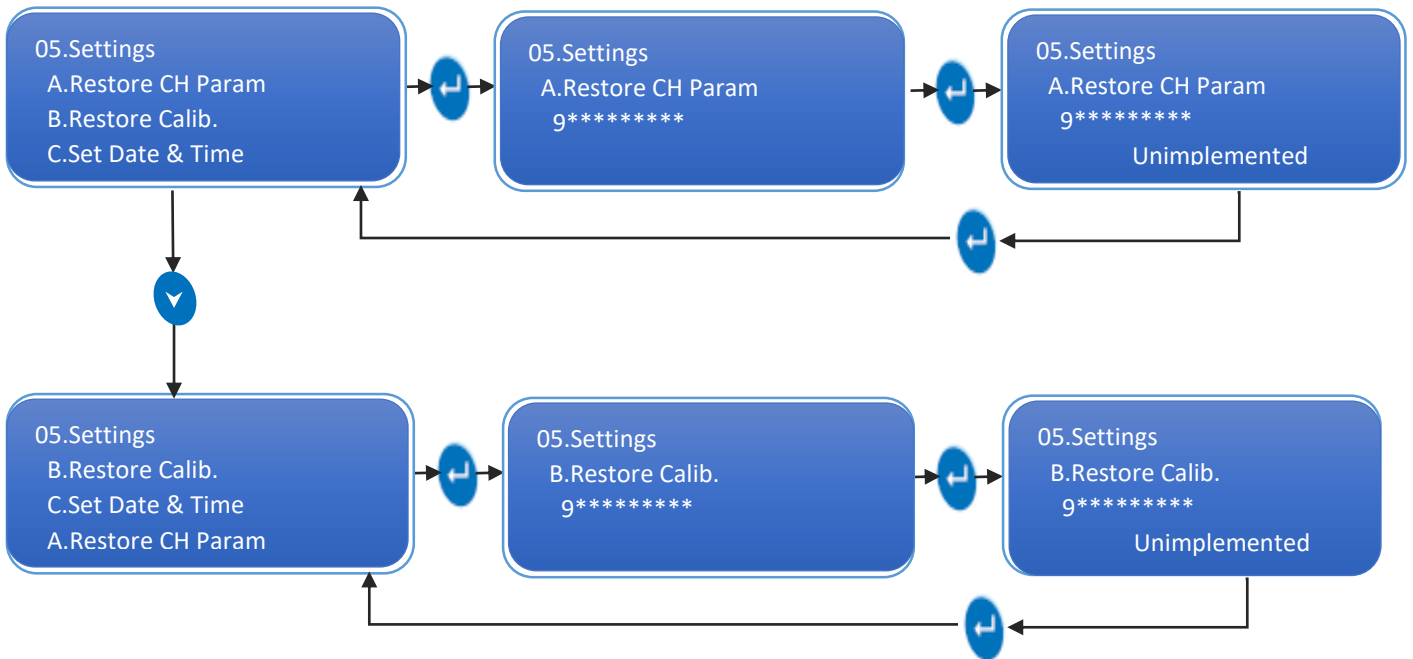

### 6.6.1 Date and Time

Sc5x9x Pro device maintains real time clock and date even when the device is Off. The datalogger also takes Leap years into consideration and maintains date and time accordingly.

Using this submenu, the user can set the Date, Month, Year, Hour, Minute and Second for SC5x9x Pro device.

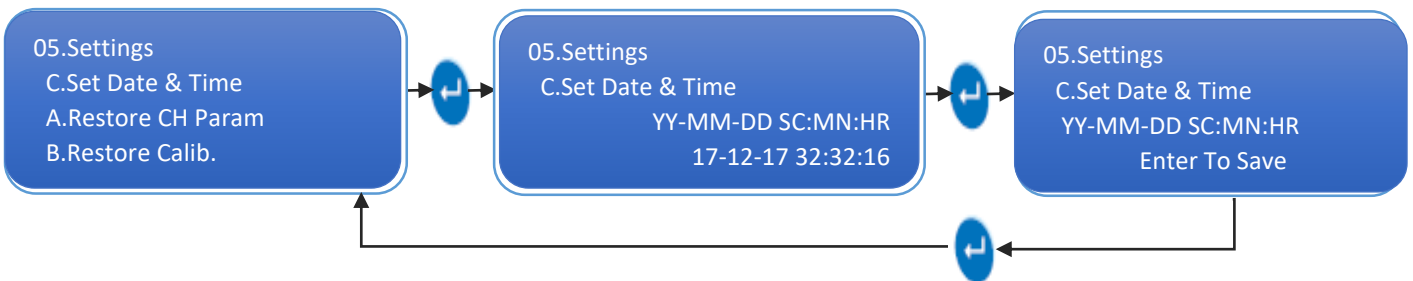

**Note:** - In Settings date and time is in YY-MM-DD SC:MN:HR format but On Default Display It Shows DD-MM-YY HR:MN:SC in format.

**Note:** - Use Shift Key to move cursor right and use Up Key and Down Key to change characters.

### 6.7 CHANNEL SKIP

The channel skip functionality allows the user to skip a specific channel from scanning. Skipping a channel will not show its reading on the default display and when the data is downloaded, the reading of the skipped channel will be shown as “NaN” or “Not a Number”.

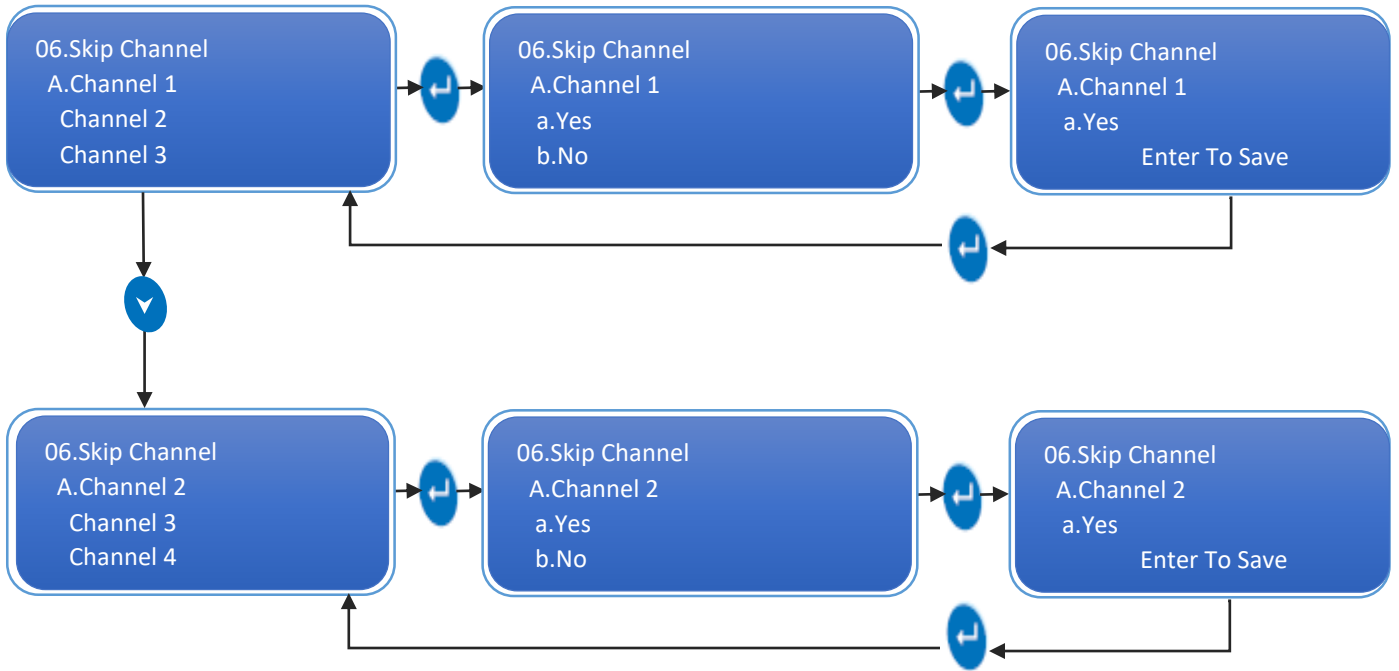

## 6.8 CJC CAPTURING

### 6.8.1 Offset

A small correction may be required when actual sensor is connected to the device. To set offset for temperature reading, a mathematical value is directly added to the reading coming on display with the reference value which we consider as an accurate value coming on other display device or machine.

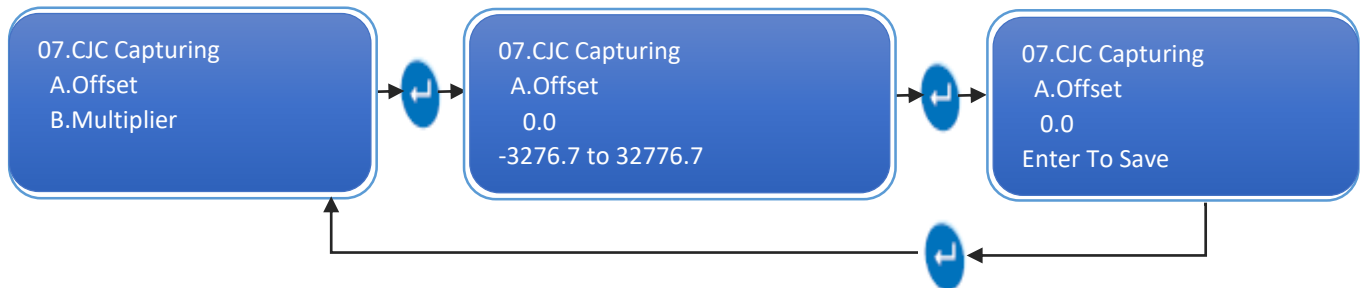

### 6.8.2 Multiplier

Sometime a major correction, may be required for temperature when actual sensor is connected to the device. A mathematical value except zero is directly multiplied to the reading coming on display to get the specific output and to store it during batch running.

To set Multiplier for CJC follow the procedure shown in figure by pressing the appropriate buttons given on the front panel of the SC5x9xpro Device.

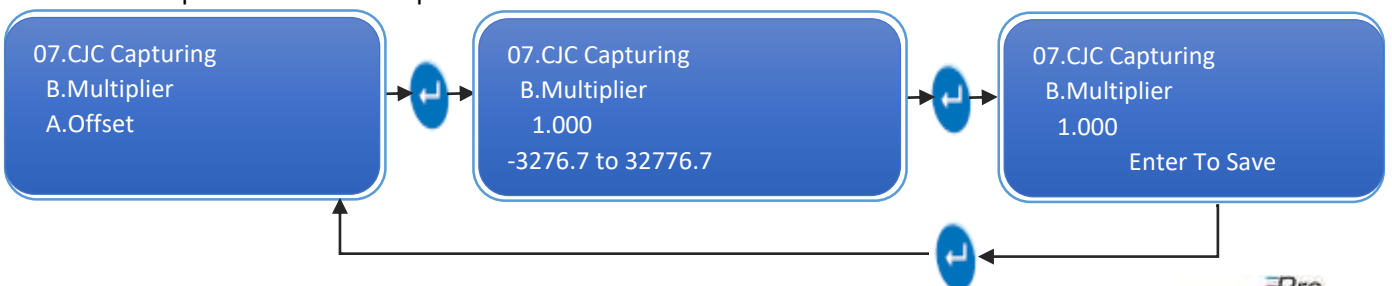

**Note:** - User Can Change Offset & Multiplier During Running Batch.

**Note:** - Use Shift Key to move cursor right and use Up Key and Down Key to change characters.

## 6.9 RELAY SETTING

The number of relays depends on the type of product the user has ordered. The user is advised to see the product code of the Sc5x9x Pro Device.

### 6.9.1 Alarm On Delay

Alarm On Delay is user settable parameter in seconds, minutes, and hour. It is more of a settling time of the channel reading. For instance, if the Alarm On Delay is kept 10min and the channel reading goes out of range, the device will wait of 10min and after that an Alarm will be generated and relay will be operated and the LED of that particular channel will turn On.

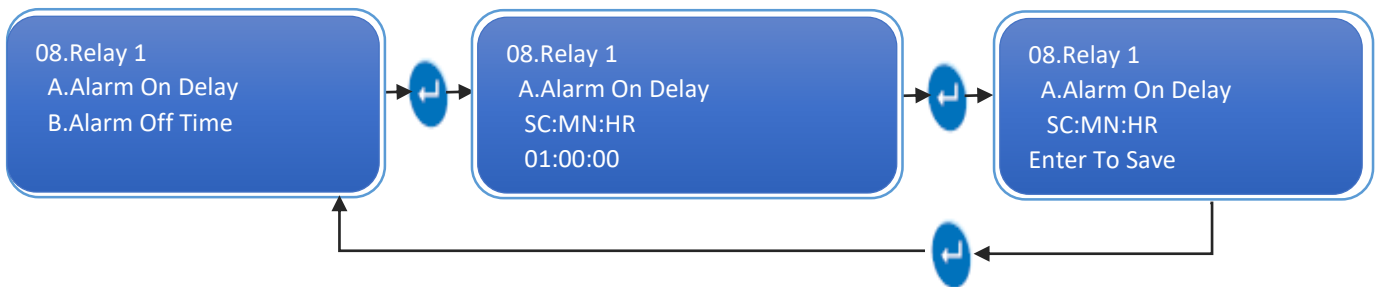

To set the Alarm On Delay, follow the procedure shown in figure by pressing the appropriate buttons given in the front panel of the SC5x9xpro.

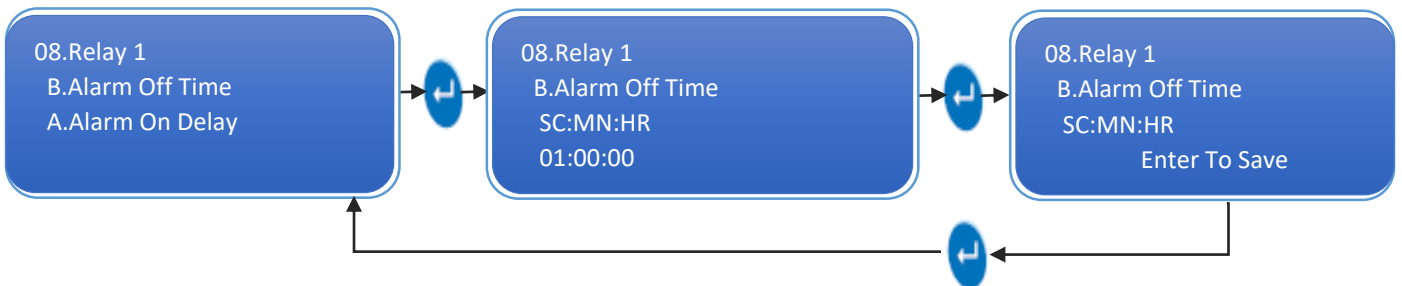

### 6.9.2 Alarm Off Time

Alarm off time is the time, for which the relays will be turned off once the alarms are acknowledged if the alarm condition persists even after this time, the alarm will go on again and relays turned on The LED indication for the alarm condition remains visible till the alarm condition is removed.



**Note:** - Use  +  Keys to Acknowledge Alarm.

**Note:** - Use Shift Key to move cursor right and use Up Key and Down Key to change characters.

## 6.10 CHANNEL CONFIGURATION

User can select any of the channel and can set the below mentioned parameters for it. There are 8 various parameters in each channel, but each channel has its different parameter values according to its use decided by user. Those parameters of every channel discussed below in detail.

### 6.10.1 Sensor Type

Three types of sensor inputs are being accepted by the Scanner

#### 6.10.1.1 RTD

It is Resistance Temperature Detector. The sensor name is PT100.

A platinum resistance temperature detector (RTD) is a device with a typical resistance of  $100\Omega$  at  $0^{\circ}\text{C}$ . It consists of a thin film of platinum on a plastic film. Its resistance varies with temperature and it can typically measure temperatures From  $-200$  to  $850^{\circ}\text{C}$ . The relationship between resistance and temperature is relatively linear.

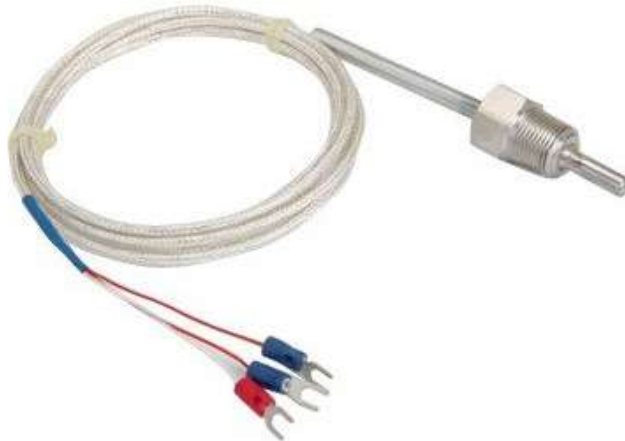

#### 6.10.1.2 Thermocouple

There are total 7 types of thermocouple inputs, the Scanner accept as listed under.

- ❖ TC-J  
It is made up of iron (+ve electrode) & constantan (-ve electrode). It operates over the temperature range of  $(-200)$  to  $(1200)^{\circ}\text{C}$  temperature. Its sensitivity is  $50\ \mu\text{V}/^{\circ}\text{C}$ .
- ❖ TC-K  
It is made up of chromel (+ve electrode) & alumel (-ve electrode). It operates over the temperature range of  $(-200)$  to  $(1300)^{\circ}\text{C}$  temperature. Its sensitivity is  $41\ \mu\text{V}/^{\circ}\text{C}$ .
- ❖ TC-R  
It is made up of plutonium (+ve electrode) & rhodium (-ve electrode). It operates over the temperature range of  $(0)$  to  $(1700)^{\circ}\text{C}$  temperature. Its sensitivity is  $36\ \mu\text{V}/^{\circ}\text{C}$ .
- ❖ TC-S

It is made up of platinum & rhodium (+ve electrode) & platinum (-ve electrode). It operates over the temperature range of (0) to (1700) °C temperature. Its sensitivity is 43  $\mu\text{V}/^\circ\text{C}$ . Mainly used for calibration for melting point of gold.

❖ TC-T

It is made up of copper (+ve electrode) & constantan (-ve electrode). It operates over the temperature range of (-200) to (400) °C temperature. Its sensitivity is 32  $\mu\text{V}/^\circ\text{C}$ . Mostly used in vacuum furnaces.

❖ TC-E

It is made up of chromel (+ve electrode) & constantan (-ve electrode). It operates over the temperature range of (-100) to (1000) °C temperature. Also used for measuring low temperature, cryogenics (-100) to (140) °C. Its sensitivity is 68  $\mu\text{V}/^\circ\text{C}$ .

❖ TC-N

It is made up of nicrosil (+ve electrode) & nilsil (-ve electrode). It operates over the temperature range of (-200) to (1300) °C temperature. Its sensitivity is 39  $\mu\text{V}/^\circ\text{C}$ .

### 6.10.1.3 Process Inputs

There are total types of process inputs that the data logger accepts,

- 4-20 mA
- 0-20 mA
- Unipolar 1 Volt
- Bipolar 1 Volt
- Unipolar 5 Volt
- Bipolar 5 Volt

One of the examples of these process input is the 4-162 Vibration sensor, giving a process output of 4-20mA proportional to various vibration ranges in terms of velocity RMS.

Unipolar voltages include only one positive voltage for logic 1. That is unipolar 1V and 5V gives 1V, and 5V output respectively for logic 1 and 0V for logic 0.

Whereas bipolar voltages give output in form of positive and negative voltages. Bipolar 1 volt and 5 volt gives output +1V and +5V for logic 1 respectively and gives -1V and -5V for logic 0, respectively.

To select sensor as RTD/ Thermocouple/ Process inputs then follow the below mentioned procedure by pressing the appropriate buttons given on the top panel of the Scanner.

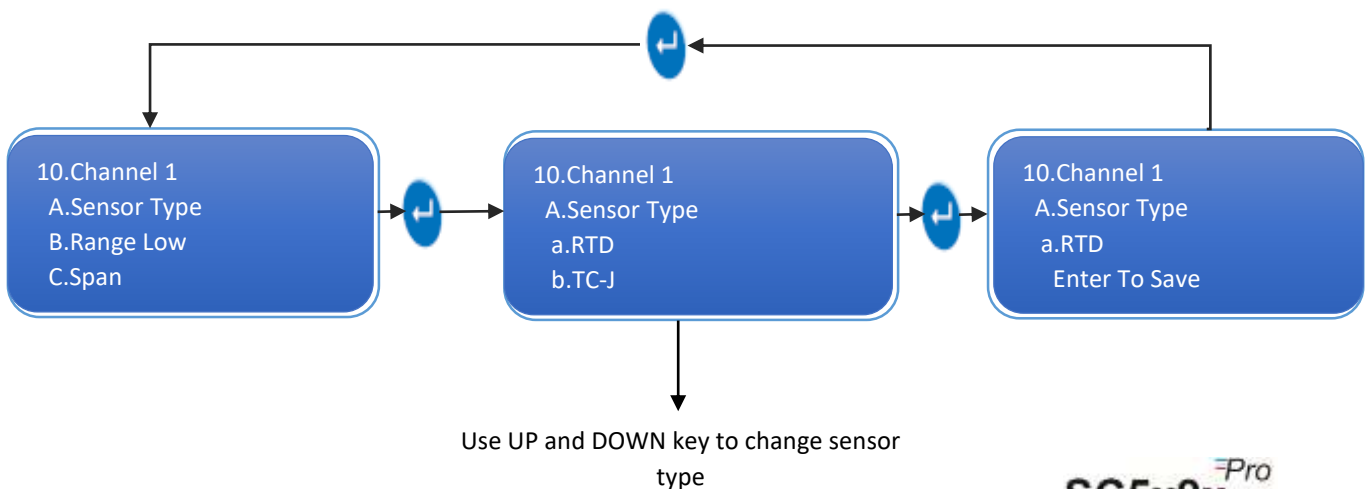

### 6.10.2 Range low

This feature is used for selecting the minimum value that should be displayed on the LCD with reference to the measured value by the sensor.

For example:

If the user wants to measure the percentage of pressure of gases in the pressure valve, then user needs to display the output in range of 0 to 100 %. So, here the range low must be set as 0 by the user.

Now, for the above case if the user wants to just measure the percentage of pressure if gone above 50% that is 50-100% then in this case the user must set the value of range low as 50.

User can set the range low values anywhere between -3276.8 to 3276.7.

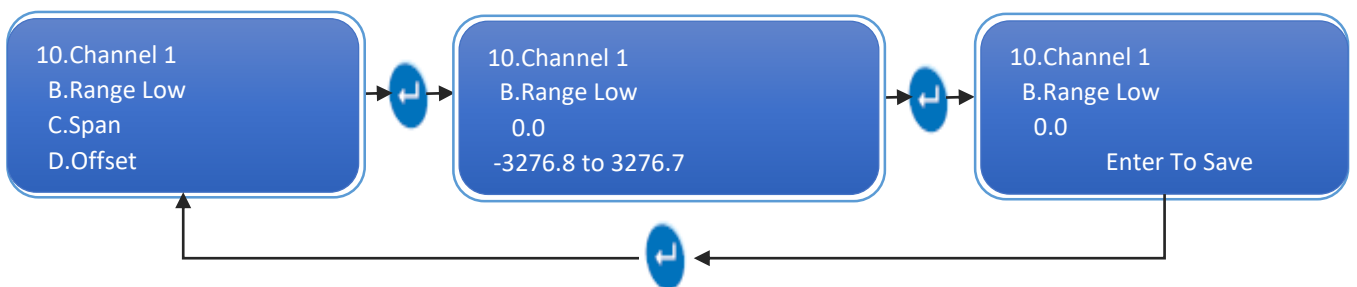

### 6.10.3 Span

Span is the total range of values that a user wants to measure. Span value indicates the total interval of which all the output values will be displayed.

For example:

If the user wants to measure the percentage of pressure of gases in the pressure valve, then then user needs to display the output in range of 0 to 100 %. So, here the span must be set as 100 by the user.

So,

$$Span = (100 - 0)$$

Now, for the above case if the user wants to just measure the percentage of pressure if gone above 50% that is 50-100% then in this case the user must set the value of span as 50.

So,

$$Span = (100 - 50)$$

User can set the Span value anywhere between -3276.8 to 3276.7.

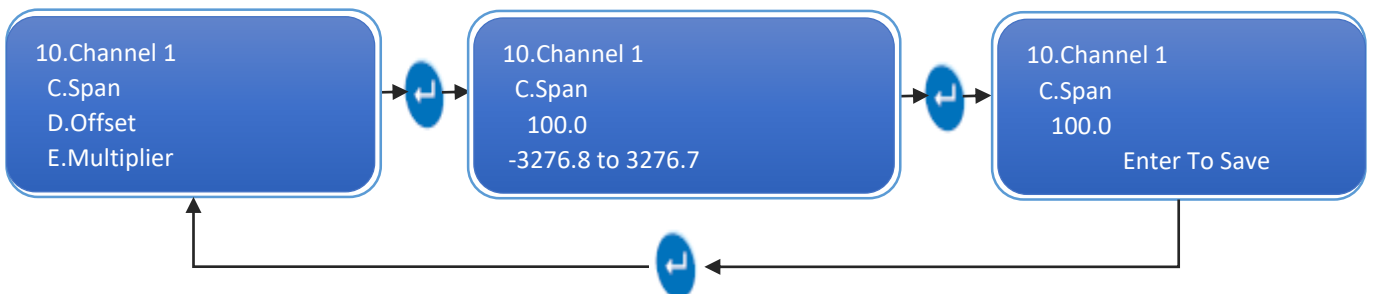

**Note:** - Use Shift Key to move cursor right and use Up Key and Down Key to change characters.

### 6.10.4 Offset

Offset is the amount of deviations that occurs in the output due to calibration errors of the sensor. Thus, if there are deviations in the output compared to the expected output, offset value should be set appropriately to null the effect.

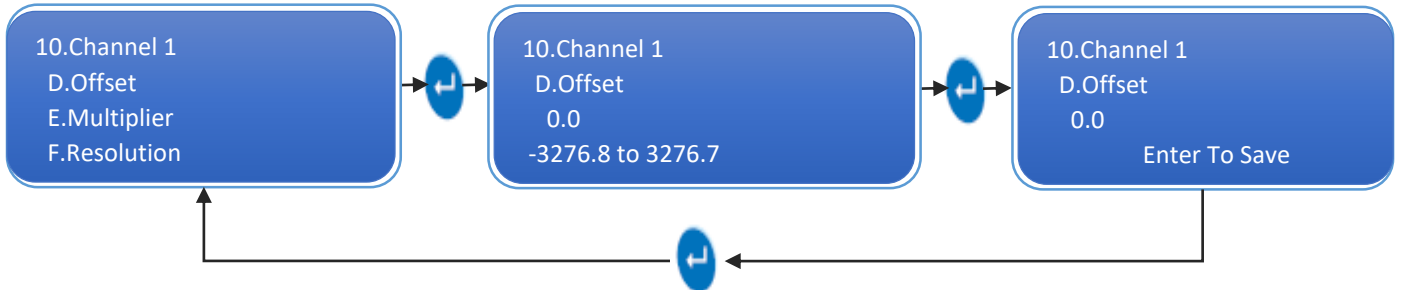

### 6.10.5 Multiplier

Multiplier is a function given for the user flexibility. If the user wants to observe the output in the range other than the actual output range, multiplier value must be set.

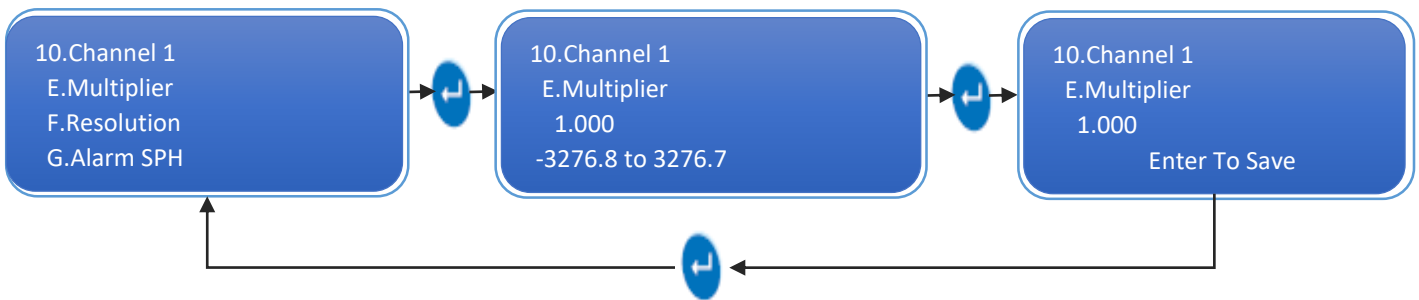

### 6.10.6 Resolution (Decimal Place)

This is the measure of the accuracy of the output value. It is the measure of number of digits that user wants to include in the output display.

For example:

If the output is 2.3012 then user can set the display output as below.

If Resolution is kept 0 then output is 2

If Resolution is kept 0.1 then output is 2.3

If Resolution is kept 0.01 then output is 2.30

If Resolution is kept 0.001 then output is 2.301

If Resolution is kept 0.0001 then output is 2.3012

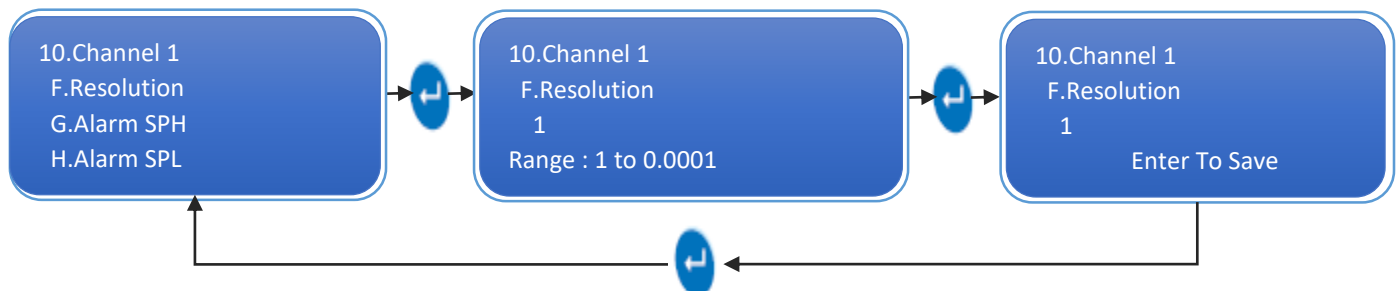

**Note:** - Use Shift Key to move cursor right and use Up Key and Down Key to change characters.

### 6.10.7 Alarm Set Point High

In this parameter, we should set the value to alert us whenever device reading goes higher than the set value, and that value should be set from -3276.8 to 3276.7.

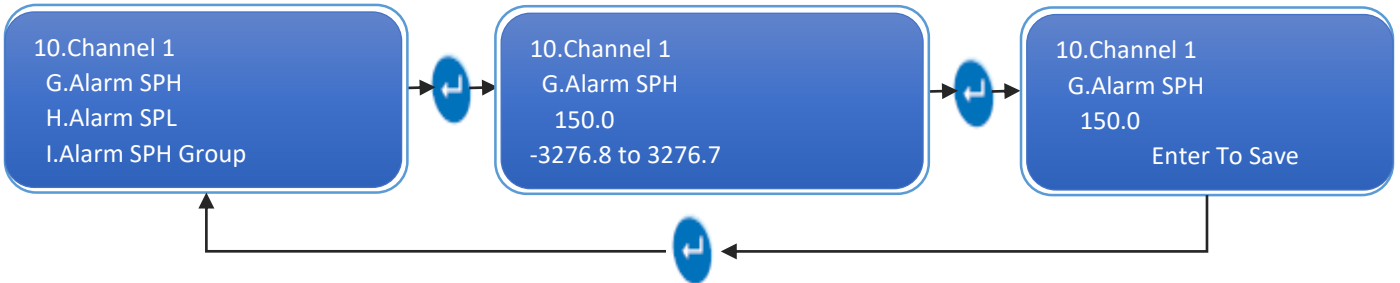

### 6.10.8 Alarm Set Point Low

In this parameter, we should set the value to alert us whenever device reading goes low than the set value, and that value should be set from -3276.8 to 3276.7

Above function Alarm set point high and Alarm set point low set the range, If the value increase and decrease from high and low range respectively then internal buzzer will turned ON along with the relay till the value does not come back within the range.

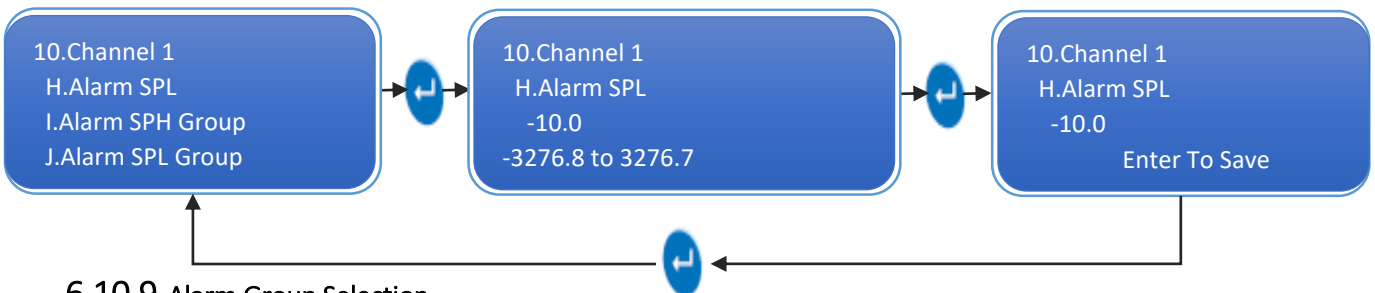

### 6.10.9 Alarm Group Selection

In this parameter, you can assign alarm group for the different channel as per convenience. For instance, if you have set Channel 1 - Alarm SPH Group as 1 and Channel 1 - Alarm SPL Group as 2, then if channel 1 reading goes high than set point high value, relay 1 get activated and if channel 1 reading goes low than set point low value, then relay 2 gets activated. So, in this way you can select different or same group number to single channel.

#### 6.10.9.1 Alarm SPH Group

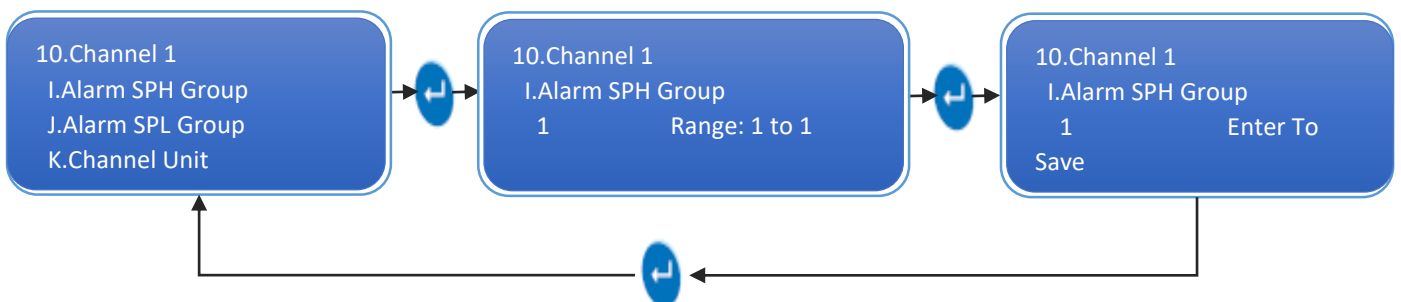

### 6.10.9.2 Alarm SPL Group

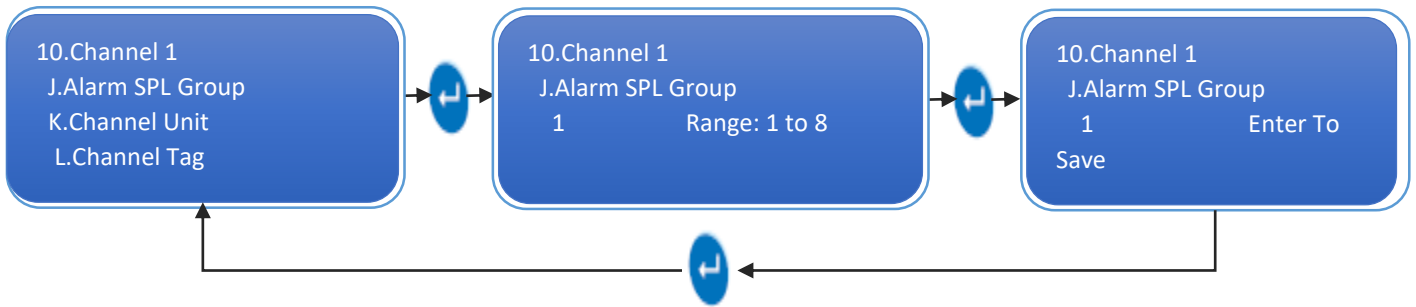

### 6.10.9.3 Channel Unit

This menu allows you to set Channel Unit to be displayed on LCD and recorded in the logs. The channel unit length is restricted to 10 characters. Use UP and DOWN key to change characters and use SHIFT key to move cursor one step in right direction.

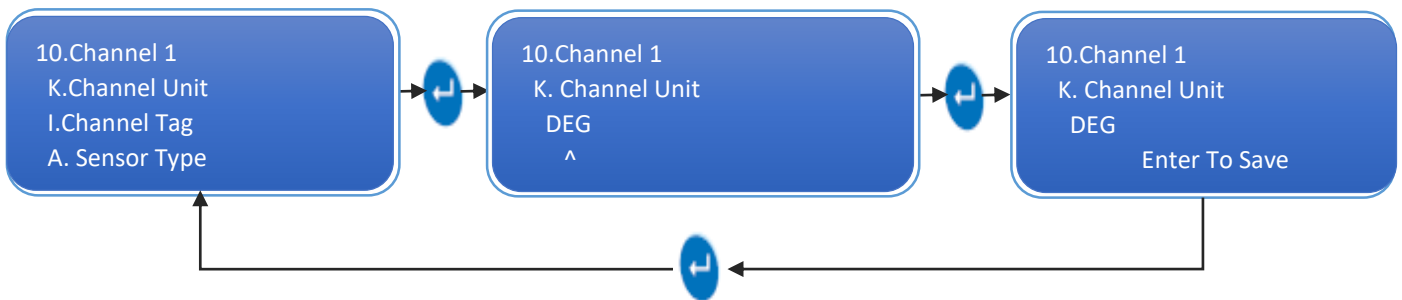

### 6.10.9.4 Channel Tag

This menu allows you to set Channel Tag which is used in Printer and Application to identify a channel. This is kind of a user defined channel name. The channel tag length is restricted to 10 characters. Use UP and DOWN key to change characters and use SHIFT key to move cursor one step in right direction.



**Note:** - Use Shift Key to move cursor right and use Up Key and Down Key to change characters.

## 6.11 GLOBAL CHANNEL CONFIGURATION

The Global Channel Configuration allows the user to use a set of channel configuration and paste it in the channel configuration of all channels.

The configuration options are same as per [Section 6.10](#). The procedure to set parameters is same as per Section 6.10 Channel Configuration.

**Note:** - User cannot save a single parameter from this menu i.e., if the user tries to save a single parameter from this menu, all the other parameters will also get saved in the memory as well as all the parameters will get inserted in all channels.

# 7 NETWORK

---

## 7.1 NETWORK CONFIGURATION

- Default Device network information:

1	IP address	192.168.1.81
2	Default Gateway	192.168.1.1
3	Subnet Mask	255.255.255.0
4	Port no	502

- Follow the below steps to configure Scanner device with application.
  1. Connect device and PC using Ethernet cable.
  2. Open Device Configuration Application.
  3. **Double Click on DeviceConfiguration.exe**

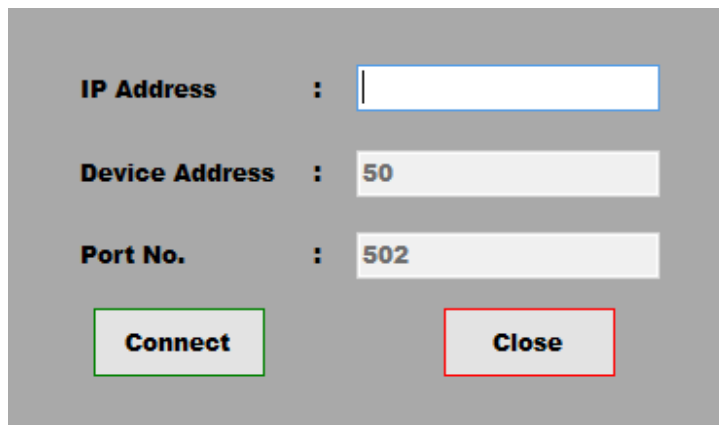

Figure 20 - Device Configuration Application

4. Enter IP Address.

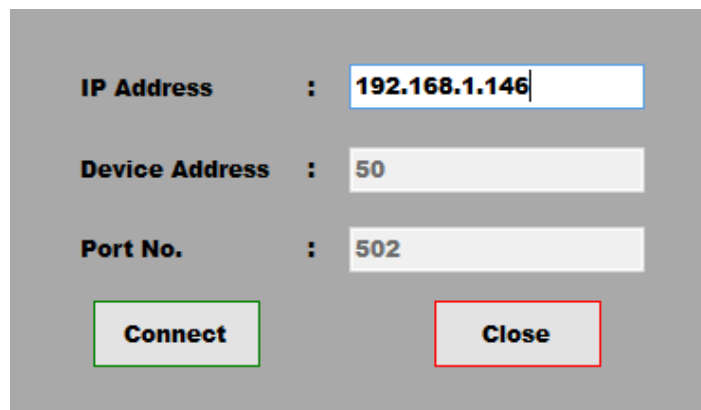

Figure 21 - Connect to Device

5. Click on Connect Button. Device Configuration will be seen if the connection is successful.

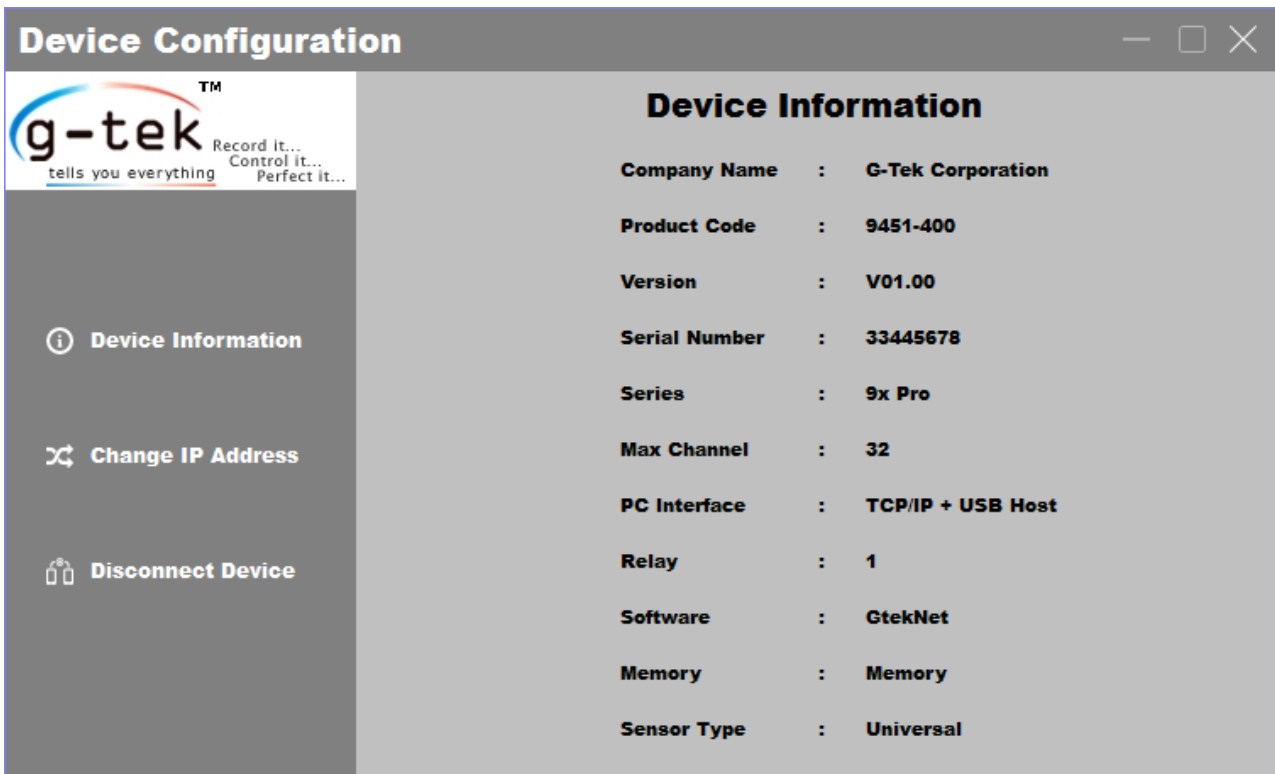

Figure 22 - Device Information

6. Click on Change IP Address Button. The current Network Configuration can be seen.

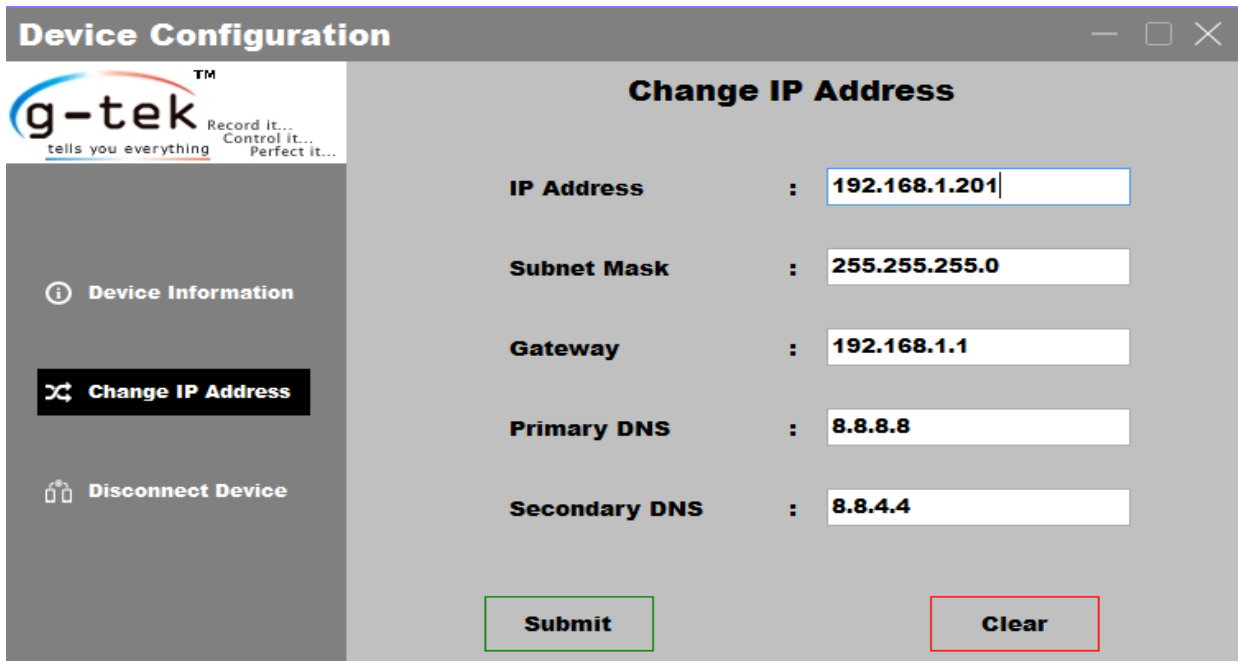

Figure 23 - Current Network Configuration

7. Click on Clear Button & Fill Network Information.

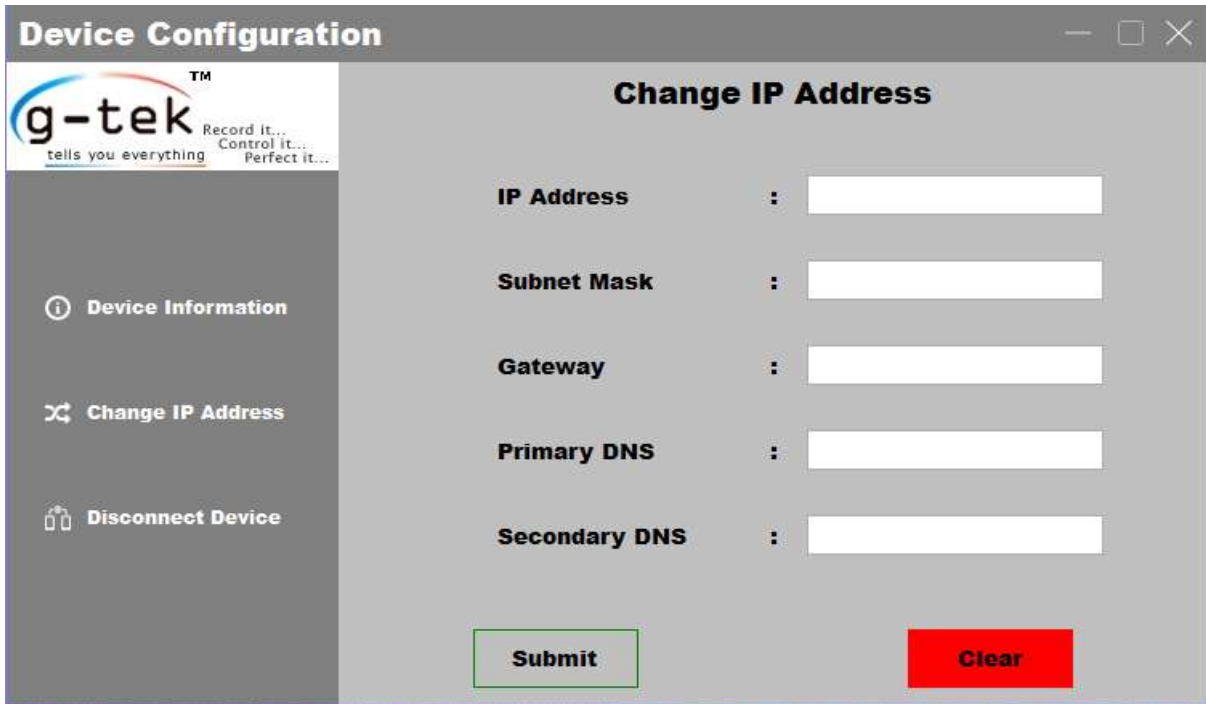

Figure 24 - Clear Network Configuration

8. After Filling the Configuration Click on Submit Button

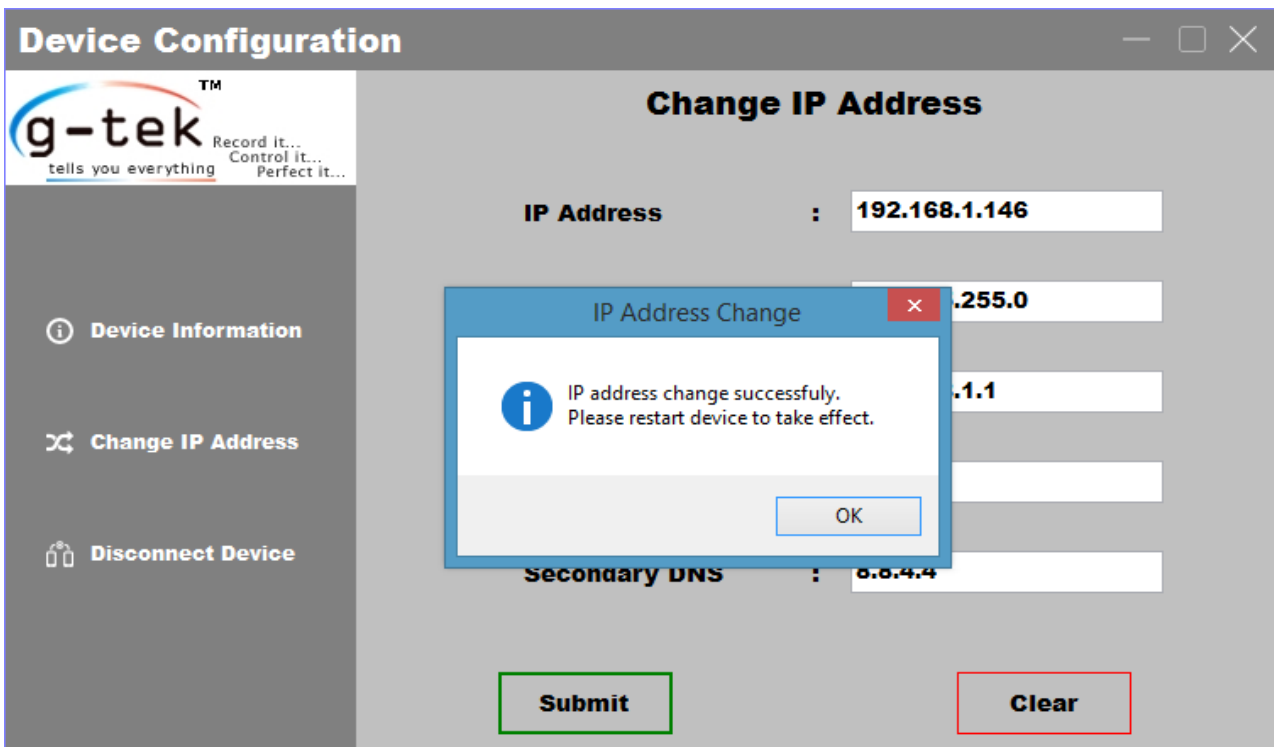

Figure 25 - IP Changed Successfully

9. After Network Configuration is changed successfully, click on Disconnect Device button.

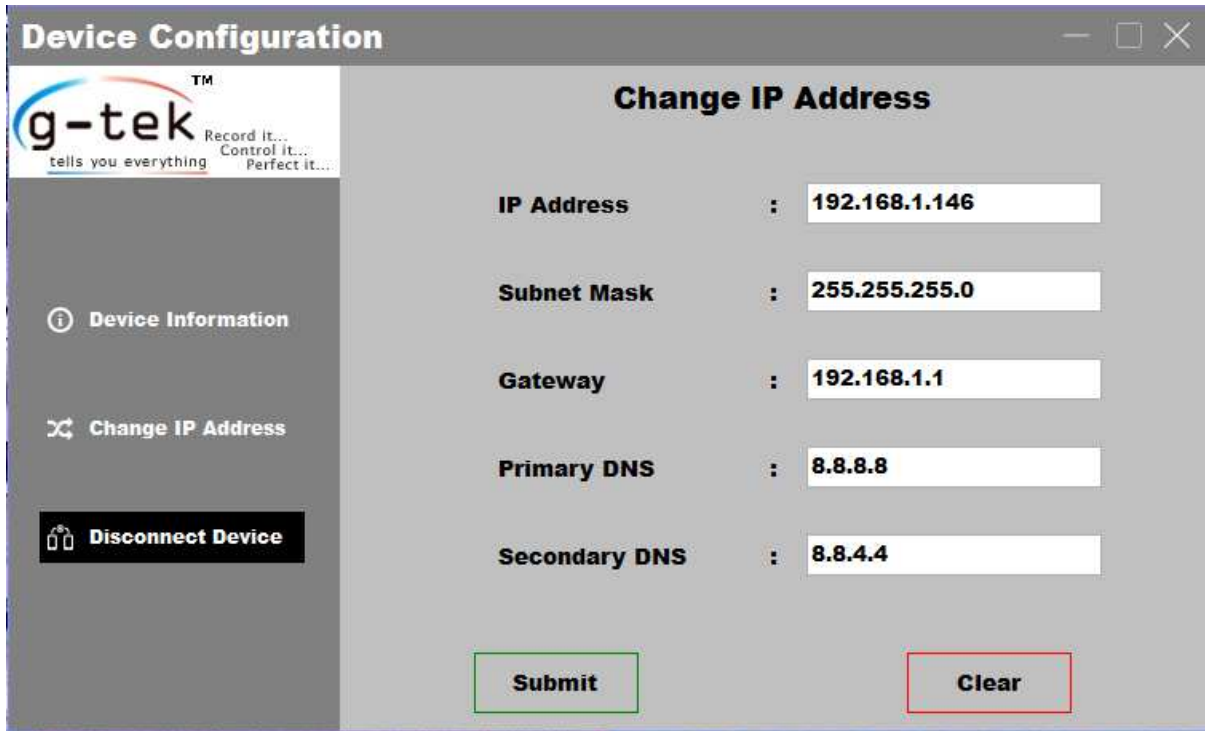

Figure 26 - Disconnect Device

10. A dialog box will pop up acknowledging that the device is disconnected successfully.

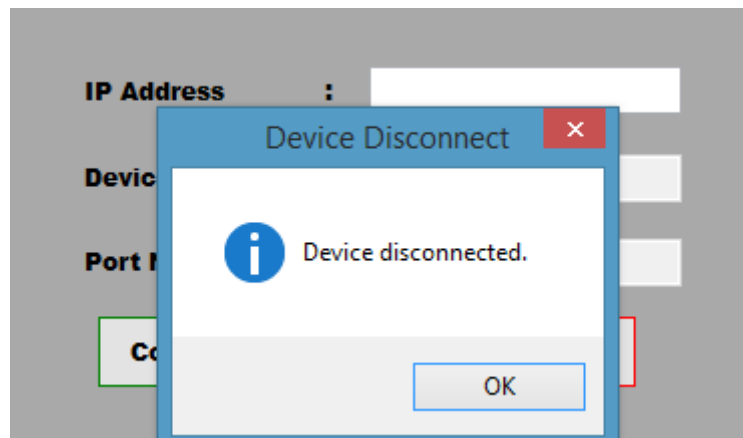

Figure 27 - Device Disconnected Successfully

## 8 READING CURRENT CHANNEL DATA ON MODSCAN APPLICATION

### 8.1 STEPS TO READ CURRENT DATA ON MODSCAN

- Open Modscan application to read the current channel data of device. Select the display option as floating point MSB first.

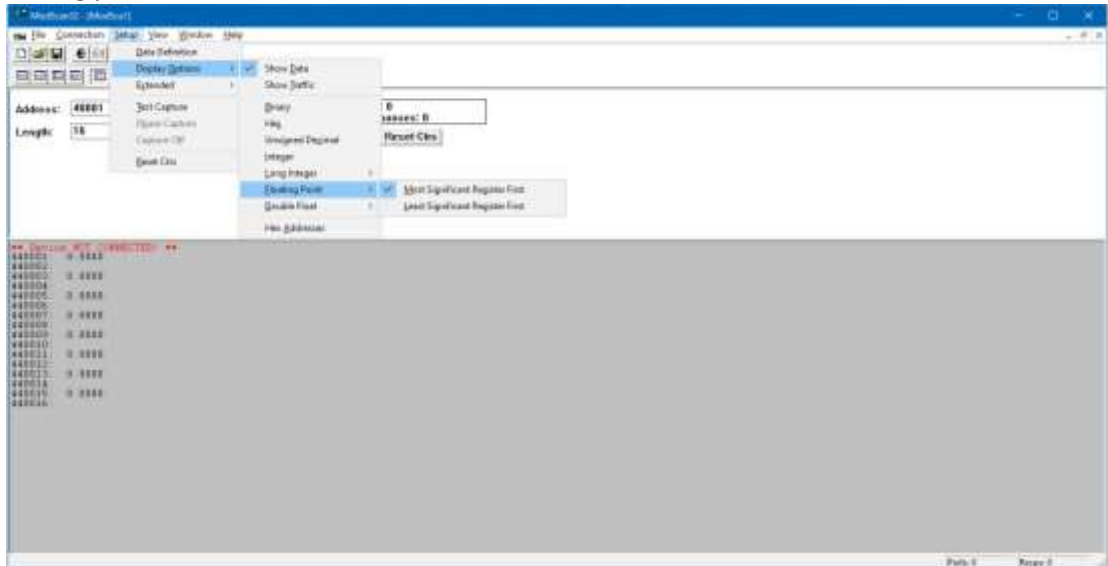

Figure 28 - Selection of display data format in Modscan

- Enter values in the setup as follows:
  - Device ID: 50 (decimal)
  - Address: 40001 (decimal)
  - Length: 16 (Length = No. of Channels \*2)
  - Modbus Point Type: 03 (Read holding registers)

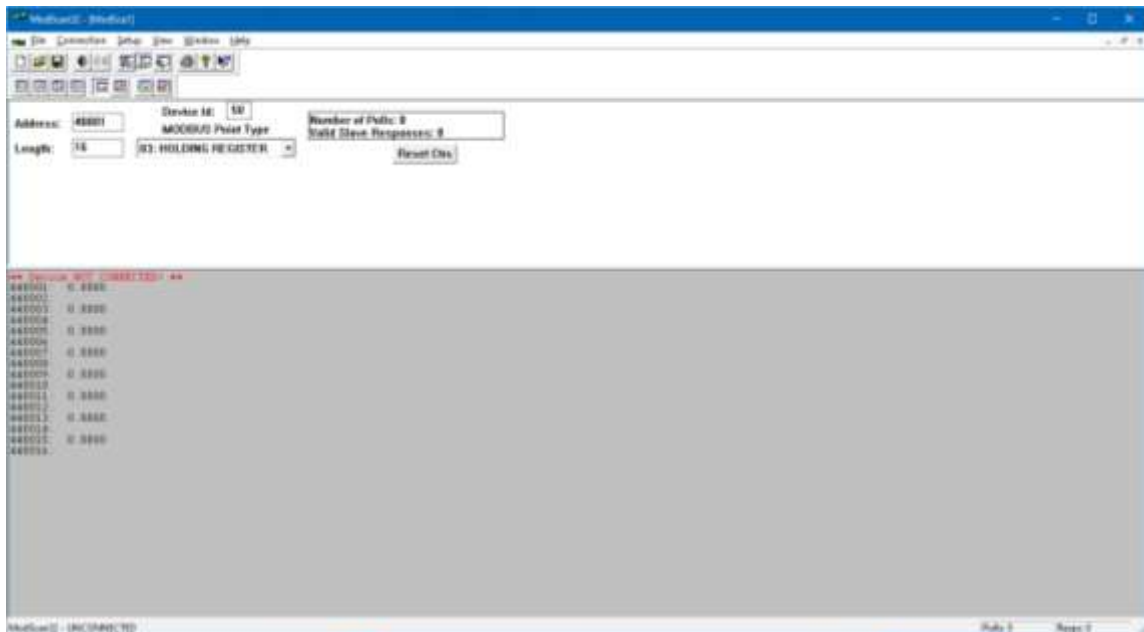

Figure 29 - Setup of device ID, Address, length and function code

- Click on Connection tab and write the device IP address.
  - Device IP Address#: 192.168.1.81 (default device IP address)

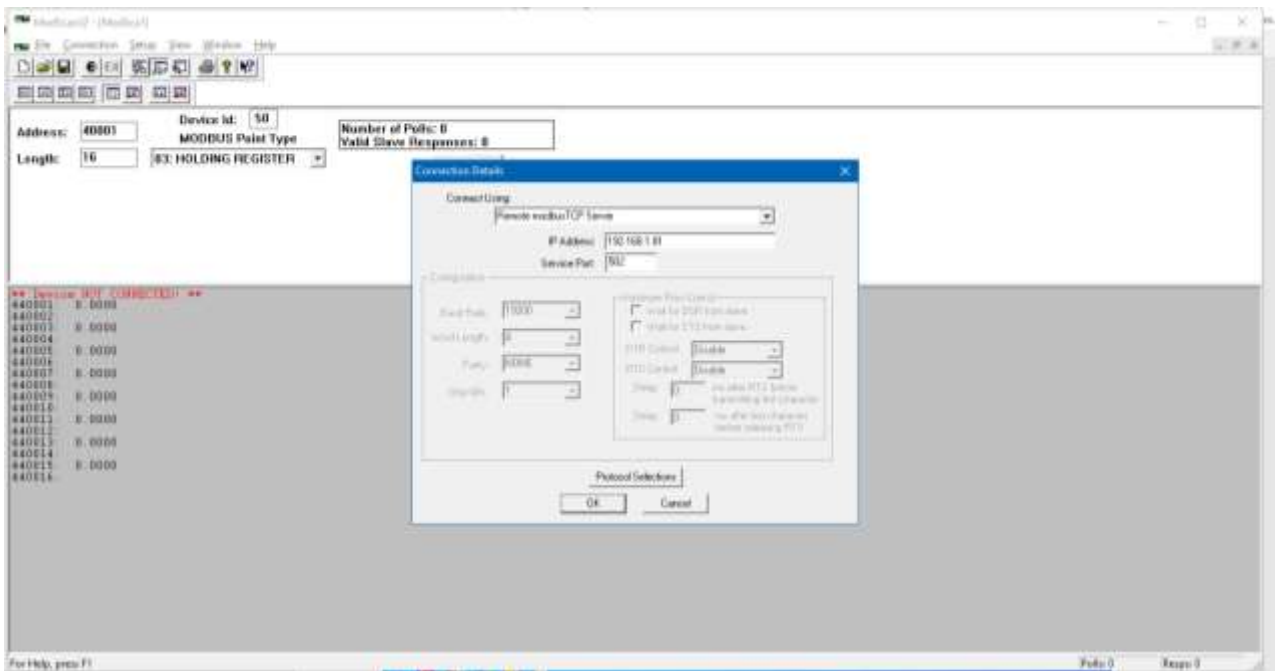

Figure 30 - Set the Device IP address for Modbus TCPIP communication

**# Enter IP address of the Scanner device.**

- Start connection by selecting OK button in Modscan.
- Select the data format as float to view current data readings of all 8 channels.

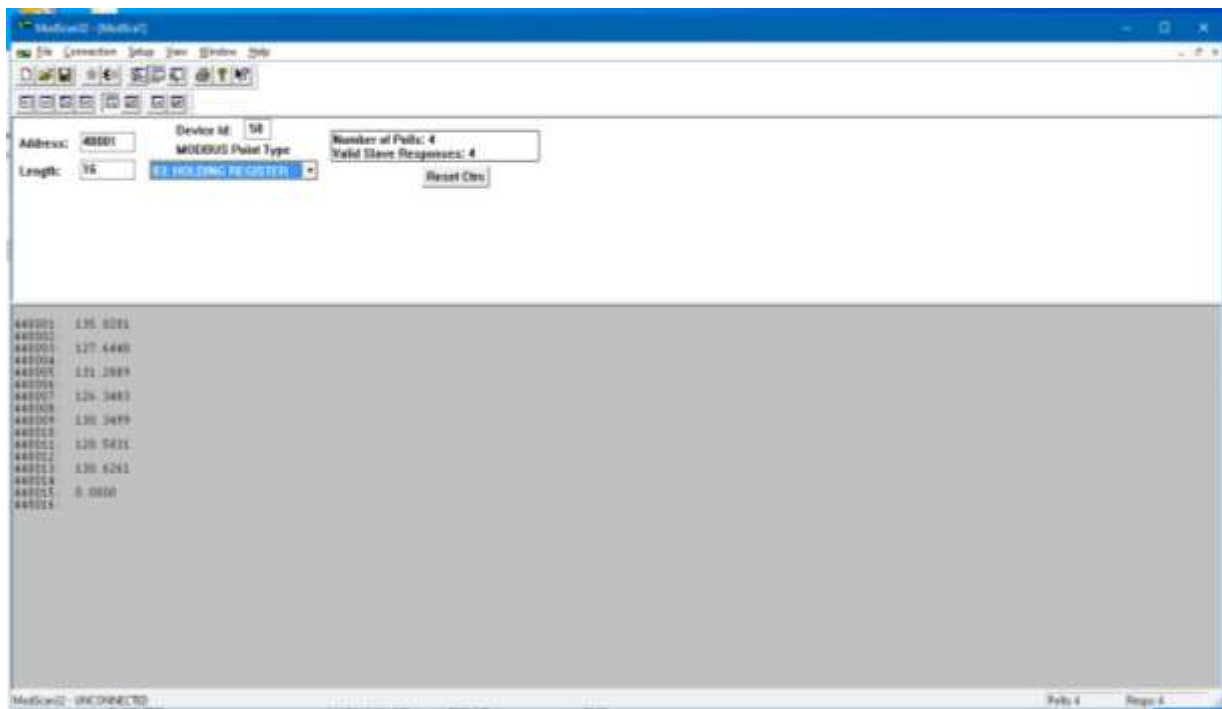

Figure 31 - Display Current channel data in floating point format

## 9 TROUBLESHOOTING GUIDE

Table 2 - Troubleshooting Guide

PROBLEM	CORRECTIVE ACTION
Display shows "G-Tek Corporation" only	<ul style="list-style-type: none"> <li>Reset the Scanner</li> <li>Check the earthing voltage, should not be more than 6V.</li> </ul>
Reading is not proper	<ul style="list-style-type: none"> <li>Check the set values of Range low &amp; Span (incase of 4-20mA, 0-20mA, 0-1V input)</li> <li>Check the external SMPS is powered on (incase of 4-20mA, 0-20mA, 0-1V input)</li> <li>Check the sensor type, offset &amp; Multiplier are set properly</li> <li>Check all the sensor cables are inserted properly &amp; there is no loose connection.</li> <li>If problem persists, contact factory.</li> </ul>
Display shows same reading	<ul style="list-style-type: none"> <li>Switch off the scanner &amp; replace the sensor. If problem persists, contact factory.</li> </ul>
Printing does not come	<ul style="list-style-type: none"> <li>Ensure that printer is connected properly &amp; powered on.</li> <li>Ensure that the online batch is turned on in the scanner.</li> <li>Ensure that the Print Interval is set properly.</li> <li>Check Printer is not in halt/pause/error mode</li> <li>Ensure that the Paper is loaded properly</li> </ul>
Data printed is not legible	<ul style="list-style-type: none"> <li>Replace the printer cable and/or Printer and verify</li> </ul>
Display is Frozen	<ul style="list-style-type: none"> <li>If required, use 3-core shielded cable for mains and earth the shield at power supply end &amp; keep the other end open at scanner side.</li> </ul>
Difference between standard equipment reading & scanner reading	<ul style="list-style-type: none"> <li>Verify the reading &amp; if required use the offset menu to Correct the error.</li> </ul>
Data logger is not working; nothing is displayed on LCD	<ul style="list-style-type: none"> <li>Please ensure that mains connector &amp; mains voltage are proper.</li> </ul>
Problem in Communicating with PC	<ul style="list-style-type: none"> <li>Check whether the LAN cable is inserted properly or not on both ends.</li> <li>Check the cable type (Straight or Cross Over). Cross Over connection type is recommended. Refer <a href="#">Section 4.1.3</a></li> <li>Communication LEDs should blink on Ethernet Connector on device.</li> </ul>
Data is not stored in Scanner	<ul style="list-style-type: none"> <li>Ensure that the batch is turned on in the Scanner.</li> <li>Ensure that the Store Interval is set properly.</li> </ul>
USB (pen drive) not detect	<ul style="list-style-type: none"> <li>Ensure USB is not Corrupted</li> <li>Ensure that device accept only up to 32GB</li> <li>Device tested using some of the branded pen drive like Toshiba, SanDisk etc. if in case your pen drive does not work then contact to company.</li> </ul>
Keyboard not working	<ul style="list-style-type: none"> <li>Ensure that keys not damage, if key board damage, then contact to company</li> </ul>
Relay not working	<ul style="list-style-type: none"> <li>Ensure relay contact switching and if still problem persist then contact to company.</li> </ul>

## 10 ACCESSORIES

---

### 10.1 PANEL MOUNTING CLAMPS

Panel Mounting Clamps: 2 numbers; Part No. 210034

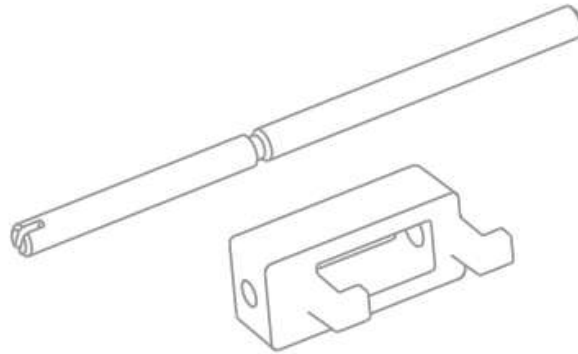

*Figure 32 - Panel Mounting kit*

### 10.2 ETHERNET CABLE

Cross Over Ethernet Cable (if PC communication is available)

Part No.: 236249



*Figure 33 - Ethernet Cable*

# 11 SPECIFICATIONS

Table 3 - Specifications

Model No	SC5x9x Pro Scanner / Data logger	
Order Code	Sc5x	Sc9x
<b>Display and Operator Panels</b>		
Display Type	4x20 Characters backlit LCD display white over blue	
Status Indicator	Various LED indication for Data Storage, Device health, SD Card mount status, USB pen drive mount status and Alarm status Indication for each channel	
Panel Keys	Front panel KB consisting of 6 keys for programming and configuration setting	
Real Time Clock (RTC)	Scrolling of RTC along with other data; user can also fix one line to continuously Display RTC.	
Event Notifications	Different events are notified on display	
Display Blinking	on Alarm high - low Condition	
Error Code	Various faults are indicated using Error Code on Display	
Display Action	Display Rolling and Freeze (Does not Display skipped channel)	
Log memory	% Log memory available on display	
Sensor Connectivity	Sensor Failure Indication on Display (Open or Short)	
<b>Analog Input Details</b>		
No Of Inputs	8/16/24/32 Channels Max.	
Sensor Input Type; Range and Accuracy*	Refer Table 4	Refer Table 5
RTD	PT-100; DIN43760, $\sigma=0.00385$	
Vdc	0-1V; $\pm 1V$ ; 0-5V; $\pm 5V$	
mA	4-20mA; 0-20mA (External Shunt Resistance of 50 $\Omega$ 0.1%)	
Thermocouple	Types J, K, R, S, T, E, N	
Linearization	Polynomial Based Software Linearization	
Resolution	0.01	
CJC Error	$\pm 0.9^{\circ}\text{C}$ for 0-50 $^{\circ}\text{C}$	
Data Scan Rate	Maximum 15 Seconds for all Channels	Maximum 3 Seconds for all Channels
<b>Protection</b>		
Input Impedance RTD/TC /Volt	> 20 M $\Omega$	
Input Impedance mA	50 $\Omega$ Shunt External	
CMRR	>110 dB@ 50, 60 Hz at 50 Sample per Second	
NMRR	>80 dB@ 50, 60 Hz at 50 Samples per Second	
Maximum Common Mode Voltage	5V AC	
Isolation Channel – EARTH	2.5KV, 1 Minute	
Input Protection	30V AC/DC Max	
<b>Batch Storage / Data Memory Details</b>		
Start / Stop	Key Press / Remote Start - Stop	
Store Interval	1 Second to 18 Hours	

<b>Memory Size</b>	16GB Standard / Expandable to 32GB / Stop on Full
<b>General</b>	
<b>Termination</b>	Non Interchangeable, Removable Plugs, Individual for Each Input
<b>Max No of Input Cards Per Device</b>	4 (8 channels each)
<b>Password Protection</b>	Optional
<b>Device RTC set</b>	Set Device RTC from application (So that PC and Device RTC are in sync while starting the batch)
<b>Environmental</b>	
<b>Temperature</b>	(Operation) 5°C to 45°C (Limiting) 0°C to 50°C (Storage) -20°C to 60°C
<b>Humidity</b>	(Operation) 10 to 80 % RH Non Condensing (Storage) 5 to 90 % RH Non Condensing
<b>Altitude</b>	<2000 meter
<b>Power Requirement</b>	
<b>Supply Voltage</b>	85-264VAC 47-63Hz
<b>Power</b>	15W Max with Maximum Configuration
<b>Transmitter Power Supply</b>	
<b>No of outputs available</b>	1
<b>Voltage</b>	12-15 V DC
<b>Max Load current</b>	30 mA
<b>Short circuit protection</b>	Yes
<b>Isolation</b>	NA
<b>Communication</b>	
<b>PC Interface</b>	Ethernet TCP/IP
<b>Ethernet</b>	10 /100 Base T (IEEE 802.3)
<b>Connector</b>	RJ45
<b>Protocols Supported</b>	MODBUS TCP/IP; HTTP; FTP
<b>Communication Activity LED</b>	Yes
<b>Isolation (Terminal – GND)</b>	1KV, 1minute
<b>Printer Interface</b>	Centronics Port
<b>USB Host</b>	If flash drive is connected, then the data is downloaded automatically
<b>Relay Output Details</b>	
<b>Max. no. of Relay</b>	1
<b>Max. no. of relay group</b>	1 (any channel/set-point can be assigned to any group)
<b>Output Type</b>	1 Form C
<b>Alarm Set-point</b>	High/Low individually settable for each channel
<b>Life Expectancy</b>	Mechanical: 10 <sup>7</sup> operations Electrical: 10 <sup>5</sup> operations
<b>Relay Contact</b>	1A 230VAC resistive
<b>Relay Refresh Rate</b>	5 Sec
<b>Isolation Relay contact – GND</b>	1.5KV 1 Minute
<b>Safety</b>	

<b>Safety/EMI-EMC</b>	IEC 61010-1/ EN 61326 Class B
<b>Pollution Degree</b>	II
<b>Installation Category</b>	III
<b>Vibration</b>	2g Peak (10Hz-150Hz)
<b>Shock</b>	IEC 61010-1
<b>IP Rating</b>	IP20
<b>Overall Dimension</b>	
<b>Dimension L x W x D (mm)</b>	210 x 192 x 96

\* Calibration test certificates are provided for commonly used sensor inputs; calibration for other sensors is carried out upon request.

Table 4 - Sensor Type, Range & Accuracy

Sensor Type	Range	Accuracy
<b>RTD Type</b>		
Pt-100	-200 to +850	±0.5% FSD ±1 Digit
<b>TC Type</b>		
E	-100 to +1000	±0.5% FSD ±1 Digit
J	-200 to +1200	±0.5% FSD ±1 Digit
K	-200 to +1300	±0.5% FSD ±1 Digit
N	-200 to +1300	±0.5% FSD ±1 Digit
R	0 to +1700	±0.5% FSD ±1 Digit
S	0 to +1700	±0.5% FSD ±1 Digit
T	-200 to +400	±0.5% FSD ±1 Digit
<b>Volt</b>		
0 to 1V	±9999	±0.5% FSD ±1 Digit
±1V	±9999	±0.5% FSD ±1 Digit
0 to 5V	±9999	±0.5% FSD ±1 Digit
±5V	±9999	±0.5% FSD ±1 Digit
<b>mA-DC</b>		
0-20mA	±9999	±0.5% FSD ±1 Digit
4-20mA	±9999	±0.5% FSD ±1 Digit

Table 5 - Sensor Type, Range, Error & Temp. Specification

Sensor Type	Standard	Range	Error	Error% Input	Error% Range	Error Temperature Coef. ppm/°C
<b>RTD Type</b>						
Pt-100	IEC751	-200 To +850	0.01°C	0.04%	0.04%	30ppm
<b>TC Type</b>						
E	IEC584.1	-100 To +1000	0.03°C	0.05%	0.06%	25ppm
J	IEC584.1	-200 To +1200	0.02°C	0.05%	0.06%	25ppm
K	IEC584.1	-200 To +1300	0.04°C	0.05%	0.06%	25ppm
N	IEC584.1	-200 To +1300	0.04°C	0.05%	0.06%	25ppm
R	IEC584.1	0 To +1700	0.04°C	0.05%	0.06%	25ppm
S	IEC584.1	0 To +1700	0.04°C	0.05%	0.06%	25ppm
T	IEC584.1	-200 To +400	0.02°C	0.05%	0.06%	25ppm
<b>Volt</b>						
0 to 1V	-	±9999	-	0.03%	0.03%	25ppm
±1V	-	±9999	-	0.03%	0.03%	25ppm
0 to 5V	-	±9999	-	0.03%	0.03%	25ppm
±5V	-	±9999	-	0.03%	0.03%	25ppm
<b>mA-DC</b>						
0-20mA	-	±9999	-	0.03%	0.03%	25ppm
4-20mA	-	±9999	-	0.03%	0.03%	25ppm

# 12 ORDERING CODE

Order Code for Sc5X9X Pro

Table 6 - Ordering Code

<b>S</b>		<b>X</b>		<b>Y</b>		<b>R</b>		-	<b>SW</b>		<b>HW</b>		<b>S</b>	
S = Series		x = Channel		Y= PC Interface		R= Relay			SW= Software		HW Type		S=Sensor Type	
5	5x Pro	1	8 Ch	0	None	0	None		2	NONE	0	non 21CFR HW	0	Uni.
9	9x Pro	2	16 Ch	3	USB Host	1	1		4	Gtek Net Non Secure	1	21CFR HW		
		3	24 Ch	4	TCP/IP				5	Gtek Net Secure				
		4	32 Ch	5	TCP/IP & USB Host									