

OPERATING MANUAL LM-XS^{Pro}

LM-XS^{Pro} ULT
Temperature Data Logger
Model No.: 99959



Manufacturers of :

- Circular Chart Recorders
- Inkless Recorders
- Paperless Recorders
- Scanners & Data Loggers
- Networked Data Loggers
- Application Software
- WHO PQS Qualified Data Loggers
- Vaccine Series Data Loggers

G-TEK CORPORATION PVT. LTD.

"Gunaji House"
Plot No. 25/1, Besides Status Bungalow,
Padra Road, Vadodara – 391410.
tel.: +91-98245 24140
e-mail: info@gtek-india.com
url: www.gtek-india.com

CONTENTS

List of Tables	3
List of Figures	3
1 SAFETY AND THE ENVIRONMENT	4
1.1. About this document	4
1.2. Ensure Safety.....	4
1.3. Protecting the Environment	4
2 SPECIFICATIONS.....	5
2.1. Use.....	5
2.2 Technical Data	5
3 UNPACKING THE PRODUCT.....	8
3.1 Unpacking and Inspection of LM-XS ^{Pro} ULT Data Logger.....	8
3.2 Mechanical Dimensions of LM-XS ^{Pro} ULT Data Logger	9
3.3 Enclosure Wall Mounting of LM-XS ^{Pro} ULT Data Logger.....	10
3.4 Sensor Connection of LM-XS ^{Pro} ULT Data Logger.....	10
4 LIST OF ABBREVIATIONS	11
5 PRODUCT DESCRIPTION.....	12
5.1 Status LEDs.....	12
5.2 Display (LCD)	12
5.3 Functions of Keys.....	13
6 USING THE PRODUCT	15
6.1 Set RTC Menu	15
6.2 View Min/Max and Current Data	16
6.3 View Current temperature	16
6.4 Main Menu Sequence	17
6.4.1 ASH (Alarm Set Point High).....	18
6.4.2 ASL (Alarm Set Point Low)	18
6.4.3 ACD (Alarm Acknowledge Delay)	19
6.4.4 HST (History Menu).....	19
6.4.5 ALH (Alarm History View)	21
6.4.6 DIF (Device Information)	22
6.4.7 UNT (Unit)	23
6.4.8 DTE (Date setting)	24

6.4.9 TME (Time setting).....	24
6.5 Measurement.....	25
6.6 Displaying of Reading in Normal and Alarm Condition	26
6.7 Buzzer Operation.....	27
6.8 Paused Function	28
6.9 Reading out Data	28
6.9.1 Connecting with the Software Application	28
6.9.2 Generating PDF report.....	29
6.9.3 PDF Report Explanation.....	31
6.9.4 Definition of Important Terms in PDF Report.....	33
7 MAINTAINING THE PRODUCT	34
7.1 Accessories.....	34
7.2 Cleaning the Data Logger	34
7.3 Battery	34
8 TIPS AND ASSISTANCE.....	35

List of Tables

Table 1 Technical Specifications	5
Table 2 Commonly used Abbreviations	11
Table 3 Status LEDs indication	12
Table 4 Frequent Asked Questions (FAQs)	35

List of Figures

Figure 1 LM-XS ^{Pro} ULT Data Logger	8
Figure 2 Overall Dimensions of LM-XS ^{Pro} ULT Data Logger	9
Figure 3 Screw Mounting	10
Figure 4 External Sensor attachment.....	10
Figure 5 External Sensor jack Inserted.....	10
Figure 6 LCD Display format.....	12
Figure 7 Set RTC Menu Sequence	15
Figure 8 View Min/Max and current Temperature.....	16
Figure 9 View Current Temperature	16
Figure 10 Main Menu Sequence	17
Figure 11 Alarm Set Point High	18
Figure 12 Alarm Set Point Low	18
Figure 13 Alarm Acknowledge Delay	19
Figure 14 History Menu to view Min/Max Temperature.....	20
Figure 15 View History data Sequence for 01 to 10 days	21
Figure 16 View Alarm History data in last 30 days.....	22
Figure 17 View Serial No., Version No. and CRC.....	23
Figure 18 Select Unit for Temperature reading	23
Figure 19 Date setting menu in dd-mm-yy format	24
Figure 20 Time setting menu	25
Figure 21 Micro USB Attachment	29
Figure 22 Selecting file location for saving data summary	29
Figure 23 Downloaded data summary.....	30
Figure 24 Selecting file location for saving PDF report.....	30
Figure 25 Sample PDF report part -1	31
Figure 26 Sample PDF report part -2	32
Figure 27 Sample PDF report part -3	32

1 SAFETY AND THE ENVIRONMENT

1.1. About this document

This instruction manual is an essential part of the product.

Please read this documentation carefully and pay attention to the safety instructions and warning notices to prevent injuries and damage to the product.

Keep this document handy so that you can refer to it when necessary.

1.2. Ensure Safety

- Operate the product properly, for its intended purpose and within the parameter specified in the technical data. Using it beyond the specified limit can cause the damage to the product and personnel also.
- Do not use the product if there are signs of damage to the housing.
- There are no user serviceable parts inside. For any defect, please consult the factory or the dealer from where you bought.

1.3. Protecting the Environment

- Dispose of faulty rechargeable batteries/spent batteries in accordance with the local regulations or valid legal specifications.

At the end of its useful life, send the product to the separate collection for electric and electronics devices (observe local regulations) or return the product to G-Tek for disposal. (Dispose or recycle the LM-XS^{Pro} ULT data logger in accordance with the WEEE 2012/19/EU guidelines or your local regulations. For the suitable recycling, the device may also be returned to the manufacturer.)

2 SPECIFICATIONS

2.1. Use

LM-XS^{Pro} ULT (Ultra Low Temperature) Data logger is an external sensor data logger meeting the requirements of **WHO PQS E006/TR06.4**. It stores the data up to 120 days and user can see the history data up to last 30 days on display without downloading or connecting the device to the computer. All the parameters and alarm limits are pre-configured as per the requirement of guidelines. They have been specifically designed for monitoring the temperature during transportation, storage of vaccines and other medical products or the medical refrigerator products subject to cold chain requirements.

The temperature readings are monitored and saved throughout the entire duration of measurement program.

LMViewXS-E006 software needs to be installed in PC To download data to generate a report in pdf format and to export data in csv format for further use.

2.2 Technical Data

Table 1 Technical Specifications

Model	LM-XS ^{Pro} ULT
General	
Remote Sensor	RTD(PT-100); Probe: diameter 5 mm, length 50 mm; spring 50 mm, 3.5 meter-long Cable
Temperature Measurement Range	-200 °C to +200 °C (-328 °F to +392 °F): External Sensor (Fixed installation)
Accuracy	± 0.5 °C for the range -200 °C to +200 °C ± 0.7 °C otherwise
Resolution	0.1 °C display and storage
Unit of Measurement	Data in °C. User has an option to view the data in °F
Calibration	Each device accompanies NABL (ISO/IEC 17025) traceable certificate
Alarm	Audio-Visual.
Alarm Low Settings*	<= 2 °C for more than 60 minutes
Alarm High Settings*	>= 8.0 °C for more than 10 hours
Response Time	T90 < 10 minutes as per EN12830:1999
Logging Interval*	Measurement interval 1 minute and Data store interval 5 minutes, pre-Fixed.
Delayed Start Option	Yes. 10 minutes after start of the device
Power Requirement	

Battery	Non-Replaceable 3.0 V 950 mAh; CR2477 Panasonic (or Equivalent) Coin Cell Battery;
Battery Life	Up to 1 year useful life and up to 0.5 years storage life. The battery indicator on the display provides information on the remaining lifetime.
Environmental Specification	
Temperature during Transportation and Storage – Device inactivated	-35°C to 70°C
Temperature during operation (Device)	5°C to 60°C (EN12830:1999 Table3, Climatic Type A)
Humidity During Transportation, Storage and usage	5 to 95% RH non-condensing
PC Interface and Software	
PC Interface	Data of more than 30 days can be extracted using LMViewXS-E006 software. History data of 30 days can be seen using device keyboard and display without attaching to PC.
Software Compatibility	LMViewXS-E006 is compatible with Windows Operating System currently supported by Microsoft.
Connectivity	USB 2.0 Type-A Ports Compatible; Data Download Time: approx. 6 minutes for full data download.
Human Interface	
Display Type	Character LCD Display with Min, Max, Battery Level Indication, OK/Alarm, calendar, clock, duration, delay counter, Alarm high and Low, Alarm marker, Bell symbol, REC/Pause indication and Current reading with measurement unit.
Memory Size	30 days overview on the display/ PDF report up to 120 days at store interval of 5mins using LMViewXS-E006 Software.
Activation	Device activation by long press of “UP” key for more than 10 seconds. Please refer to the operating manual for more details.
De-Activation	Cannot be manipulated, reset or deactivated without destroying it.
Status Indicator	RUN: Red LED flashes while device is activated. STP: Red LED flashes while device is not activated.
Alarm Visual	Flashing temperature reading on display along with ↑ or ↓ arrow for high or low alarm with bell symbol.
Alarm Audio*	Buzzer Output > 65 dBA. Buzzer will beep in alarm high/low condition.
Alarm Acknowledgement	After alarm acknowledgment, Buzzer will be deactivated for 1 hour
Power ON Indication	“RUN” LED blinks in active mode; LCD shows temperature data along with “REC” and alarm indications if any.
Mounting Device	Through 2 holes provided. Refer to operating manual for details
Material	Polycarbonate Plastic: non-breakable, non-corrodible housing
Warranty	12 months from the date of dispatch. Refer to warranty certificate for more details.

Service Provision	No user serviceable parts inside.
Physical Characteristics	
Overall Dimension (L x W x H) mm	128 x 60 x 22 mm
Weight	Approximate 120 grams
Standards	
Electromagnetic Compatibility	IEC 61000-6-2/6-3
Resistance to Electrical Storms	IEC 61000-6-2; (IEC 61000-4-2 Basic Standard for applicability of tests)
IP Rating	IEC 60529: IP 64 (External Sensor not Plugged in);
Impact Resistance	5 drops from 1 meter onto concrete floor at room temperature with battery in place. Device does not get damaged and there is no loss of calibration.
Vibration	EN 12830:1999 Clause 4.9.3.2 and Test Method 5.6.6
RoHS	Compliant (EU directive 2011/65/EU)
Verification	In accordance with PQS verification protocol E006/TR06.VP.4

*: Current alarm settings are pre-fixed from factory as per requirements of WHO/PQS/E006/TR06.4. Other settings are available on request.

3 UNPACKING THE PRODUCT

3.1 Unpacking and Inspection of LM-XS^{Pro} ULT Data Logger

- LM-XS^{Pro} ULT (Ultra Low Temperature) data logger is dispatched in a recyclable, environment friendly package specially designed to give adequate protection during transit.
- If the outer box shows sign of damage, it should be opened immediately, and the device be examined. If the device is found damaged, it should not be operated, and the local representative contacted for instructions.
- Ensure that all accessories and documentation are removed from the box.
- If the LM-XS^{Pro} ULT data logger is for immediate use, you can start installing it as per Installation instructions.
- **Please preserve the original packaging along with all internal packing for future transport requirements.**

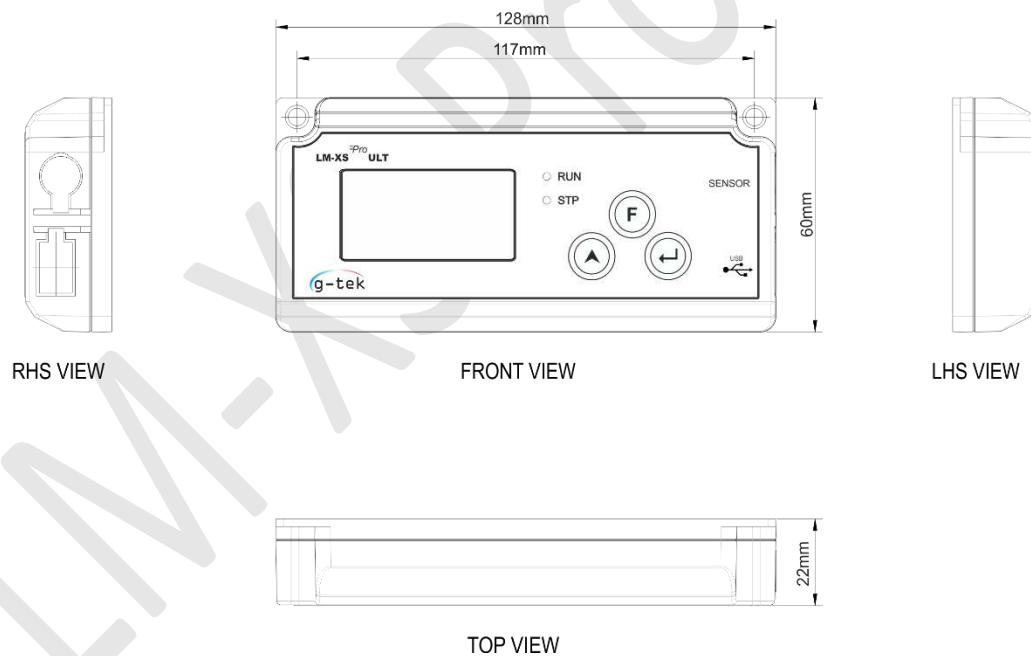
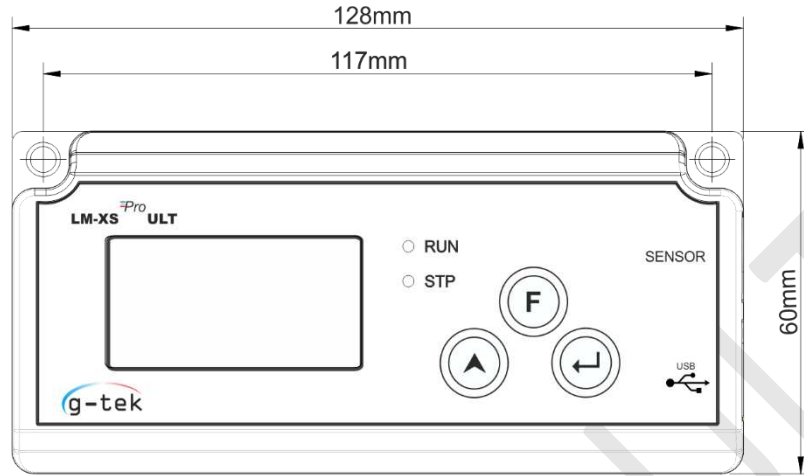

Figure 1 LM-XS^{Pro} ULT Data Logger

3.2 Mechanical Dimensions of LM-XS^{Pro} ULT Data Logger



FRONT VIEW



TOP VIEW

Figure 2 Overall Dimensions of LM-XS^{Pro} ULT Data Logger

Overall Dimensions	
Dimension (L x W x H) mm	128 x 60 x 22 approx.
Mounting	Screw Mounted
Weight	Approx. 120gms

3.3 Enclosure Wall Mounting of LM-XS^{Pro} ULT Data Logger

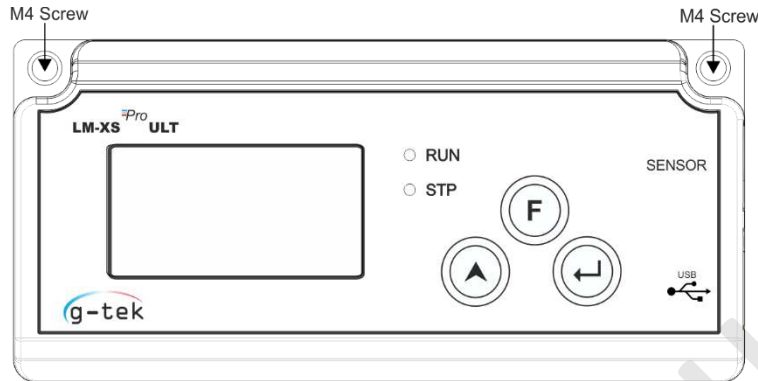

Figure 3 Screw Mounting

3.4 Sensor Connection of LM-XS^{Pro} ULT Data Logger

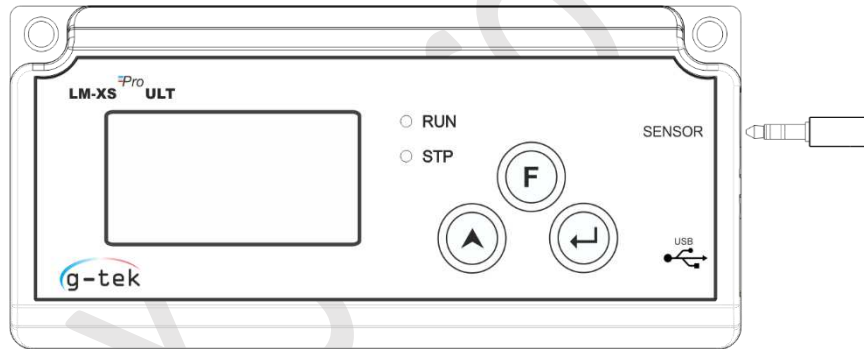

Figure 4 External Sensor attachment

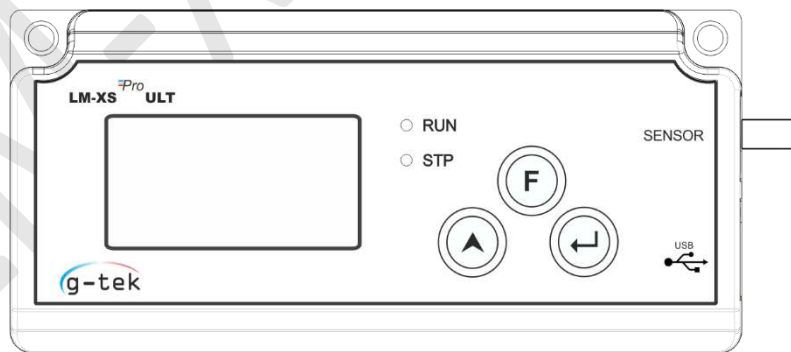

Figure 5 External Sensor jack Inserted

- Sensor will be inserted in the LM-XS^{Pro} ULT data logger using 4 contact 3.50 mm Stereo jack connector. Connect sensor cable as per figure 5.

4 LIST OF ABBREVIATIONS

Table 2 Commonly used Abbreviations

Abbreviation	Description
ULT	Ultra Low Temperature
dtF	Calendar format
dtE	Date setting
tME	Time setting
dd	Date
MM	Month
YY	Year
Hr	Hour
Mn	Minute
ASH	Alarm Set Point High
ASL	Alarm Set Point Low
ACd	Alarm Acknowledge Delay
ALA	Alarm Acknowledged
HSt	History
YES	Yes
ALH	Alarm History
dIF	Device Information
CrC	CRC checksum
Unt	Unit of temperature reading
CEL	Celsius
FAH	Fahrenheit
SAV	Save
Err	Error
SnC	Sensor not connected

5 PRODUCT DESCRIPTION

5.1 Status LEDs

Table 3 Status LEDs indication

Indicator	Description
RUN	Data Recording has started. At this time, the “STP” LED will be off and “RUN” LED flashes.
STP	Data Recording is Off, and device is On. At this time, “RUN” LED will be off and “STP” LED flashes.

5.2 Display (LCD)

The multi Character LCD Display consists of OK/Alarm, Bell, Min/Max, Battery Level Indication, Alarm high and Low, Rec/Pause, alarm day marker, day, calendar, clock, duration, delay counter, date/time/duration text and Current reading with measurement unit. The position and description of each segment is shown in figure 6.

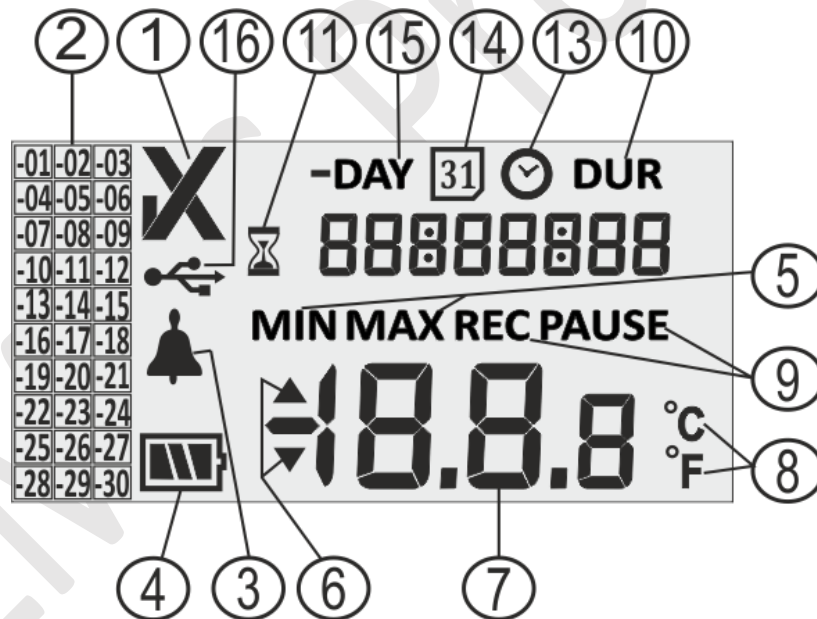





Figure 6 LCD Display format

- 1) OK ✓ / NOK X symbol:
 - a. If any time in last 30 days, alarm limits are crossed, the symbol “X”, **NOK will be turned on and will remain even if the alarm is acknowledged.**
 - b. If any time in last 30 days, alarm limits are not crossed, the symbol “✓” remains on the display.

- 2) Alarm indication marker for history of last 30 days;
 - a. "-01" means the alarm was there on yesterday
 - b. "-02" means the alarm was there on day before yesterday.
 - c. To understand better, let us assume today is 31-01-2021. Then "-01" will be 30-01-2021; "-02" will be 29-01-2021; "-10" will be 21-01-2021 and similarly "-30" will be 01-01-2021.
- 3) Bell symbol for alarm indication
- 4) Battery capacity: Sufficient  ; Partly empty  ; Low  ; Empty 
- 5) Min: Minimum stored reading for the given day
Max: Maximum stored reading for the given day
- 6) Upper ▲ / Lower ▼ limit if reading exceeded alarm limits.
- 7) Current temperature reading
- 8) Temperature Measurement unit (°C / °F)
- 9) Recording state indicators – REC - Recording; PAUSE – Recording Paused. When recording is paused, actually the data is recorded at the store interval but this data is not considered to calculate Min/ Max / Alarm duration. **PAUSE will be auto resumed to REC after 15 minutes.**
- 10) Digits used to display various parameters like Day, Date, time and duration.
- 11) Delayed start indicator: when first time logger is started by setting calendar, it will wait for 10 minutes to start logging the data. During these 10 minutes time only, this sand clock symbol will be on. This symbol will also come on during PAUSE mode.
- 12) DUR: Total alarm time duration symbol
- 13) Clock symbol: This symbol comes along with time displayed in digits
- 14) Calendar symbol: This symbol comes along with date displayed in digits
- 15) -DAY: Previous day(s) number indicator symbol for History data
- 16) USB connection symbol

Note: For Technical reasons, the display intensity of liquid crystal display becomes lower at temperatures below 0°C. This has no influence on the measuring accuracy. For technical Reasons, the battery performance decreases at lower temperatures. We Recommend the use of fully charged batteries to avoid a reset of the instrument at low temperatures.

5.3 Functions of Keys



Function (Set) key: It is used to enter main menu or come out from the main menu/submenu.



UP Key: It is used to increment the parameter value or go to the next submenu and for activating device when device goes to sleep mode.



Enter key: It is used to store the parameter value and to enter in menu for modification.

In addition to above functionality, keys are used for following functions:

Device Activation

- LM-XS^{Pro} ULT data logger is dispatched in deep sleep mode.
- **Please connect the sensor before activating the device.** To activate the LM-XS^{Pro} data logger, press **“Up”** key for about 10 seconds.
- Once the device is activated, all segments of display will turn ON for 5 seconds followed by calendar format selection and set RTC of the data logger.
- **If RTC is not set, the data logger will go in deep sleep mode again within 1 minute.**
- After RTC is set, device batch will start after **10 minutes** of device activation. During this delay time, sand clock symbol will be visible and **“STP”** LED will be flashing. Once the recording of data is started, **“STP”** LED turns off and **“RUN”** LED starts flashing and **“REC”** message is seen on display.

Min/Max

- Press **“Function”** and **“Up”** key at the same time for 1 sec, the display will start showing Min /Max temperature data of the current day in order.

Current Data

- Press **any key** for 1 sec, the display will show current temperature data.

Alarm Acknowledge

- Press **“Function”** and **“Enter”** key simultaneously to acknowledge the alarm high/low condition. The buzzer will be deactivated for prefixed 1 hour time Delay.
- After 1 hour acknowledgement delay, if alarm high/low condition persists, buzzer will activate again.

6 USING THE PRODUCT

6.1 Set RTC Menu

Once the LM-XS^{Pro} ULT data logger is activated by pressing “Up” key for 10 seconds, the user must set the RTC first. The user can set the RTC in one of the available calendar formats: “dd-mm-yy” or “mm-dd-yy” by following the sequence as shown in figure 7. **Once selected, date format cannot be changed throughout the life of data logger.** If the user has not set the RTC parameters, the device will go back in deep sleep mode.

After setting the proper RTC, start delay counter (10 minutes) will be turned ON and sand clock symbol will be turned ON.

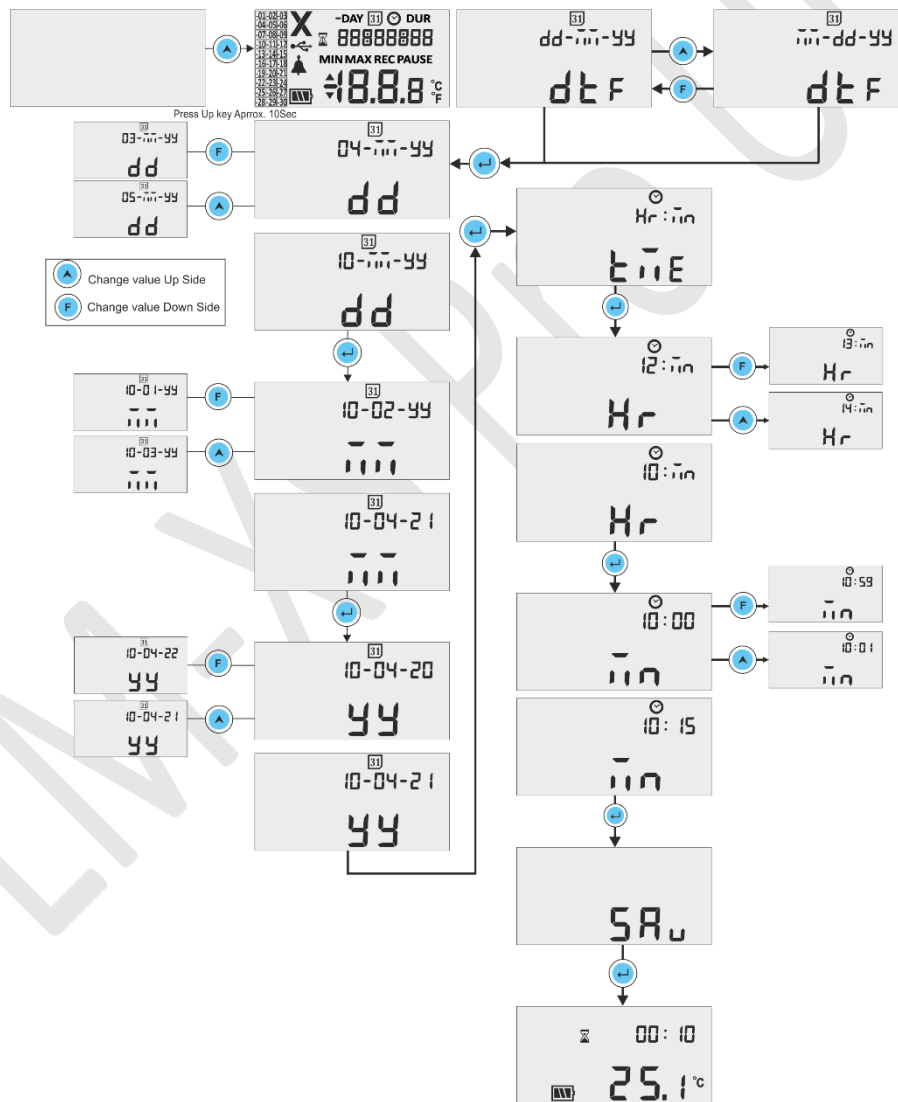

Figure 7 Set RTC Menu Sequence

Note:

1. Calendar format is set as “dd-mm-yy” default. Here, Blinking Segments indicates current selection. The calendar format followed throughout in the manual is “dd-mm-yy”.
2. Date validation is done as per month and year entered in Set RTC and date setting menu. E.g.
 - If user has entered the value 31 in date, 06 in month and 21 in year, it will be autocorrected as 30-06-21 (dd-mm-yy).
 - If user has entered the value 29 in date, 02 in month and 21 in year, it will be autocorrected as 28-02-21 (dd-mm-yy).

6.2 View Min/Max and Current Data

As described in key functions ([section 5.3](#)), by pressing “Function” and “Up” key at the same time for 1 sec in normal running condition, the display will show Min/Max temperature data for today respectively. After that display will show current temperature data as shown in figure 8.

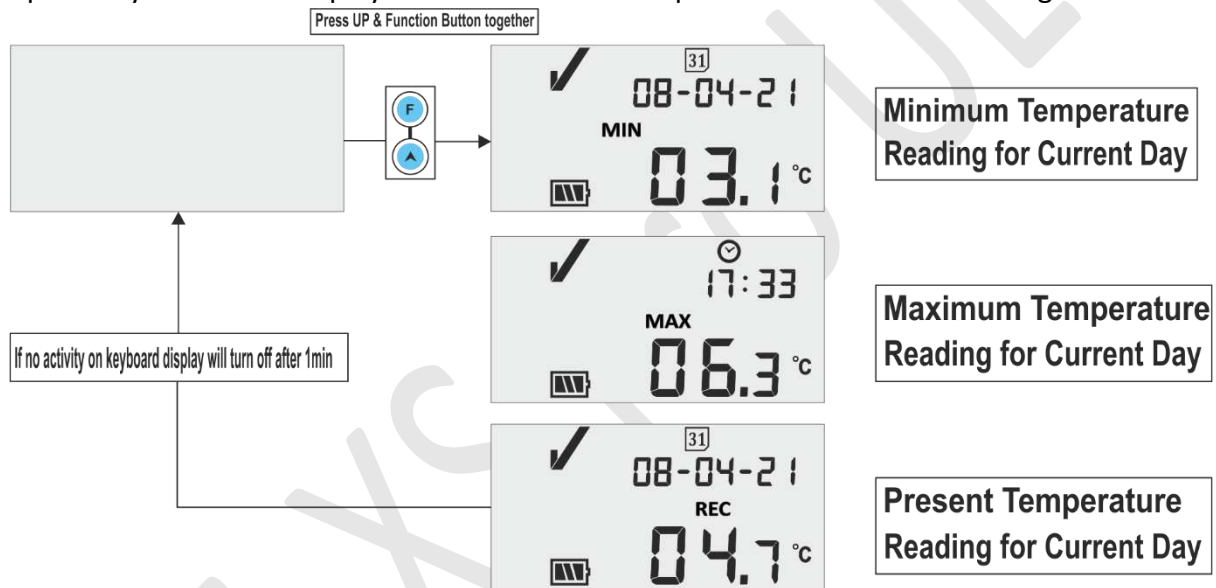

Figure 8 View Min/Max and current Temperature

6.3 View Current temperature

The user can view current temperature by pressing any key of keyboard as shown in figure 9.

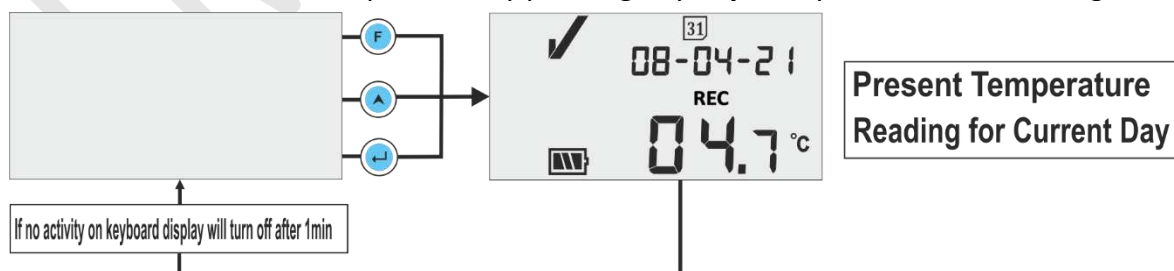

Figure 9 View Current Temperature

Note: Current date and time is displayed alternatively at every 3 seconds.

6.4 Main Menu Sequence

The user can view/set configuration setting of LM-XS^{Pro} ULT data logger using main menu. In this menu, the user can view Alarm set point high/low along with its duration, Alarm acknowledgement delay, history data, alarm history data and device information whereas the user can set unit, date and time.

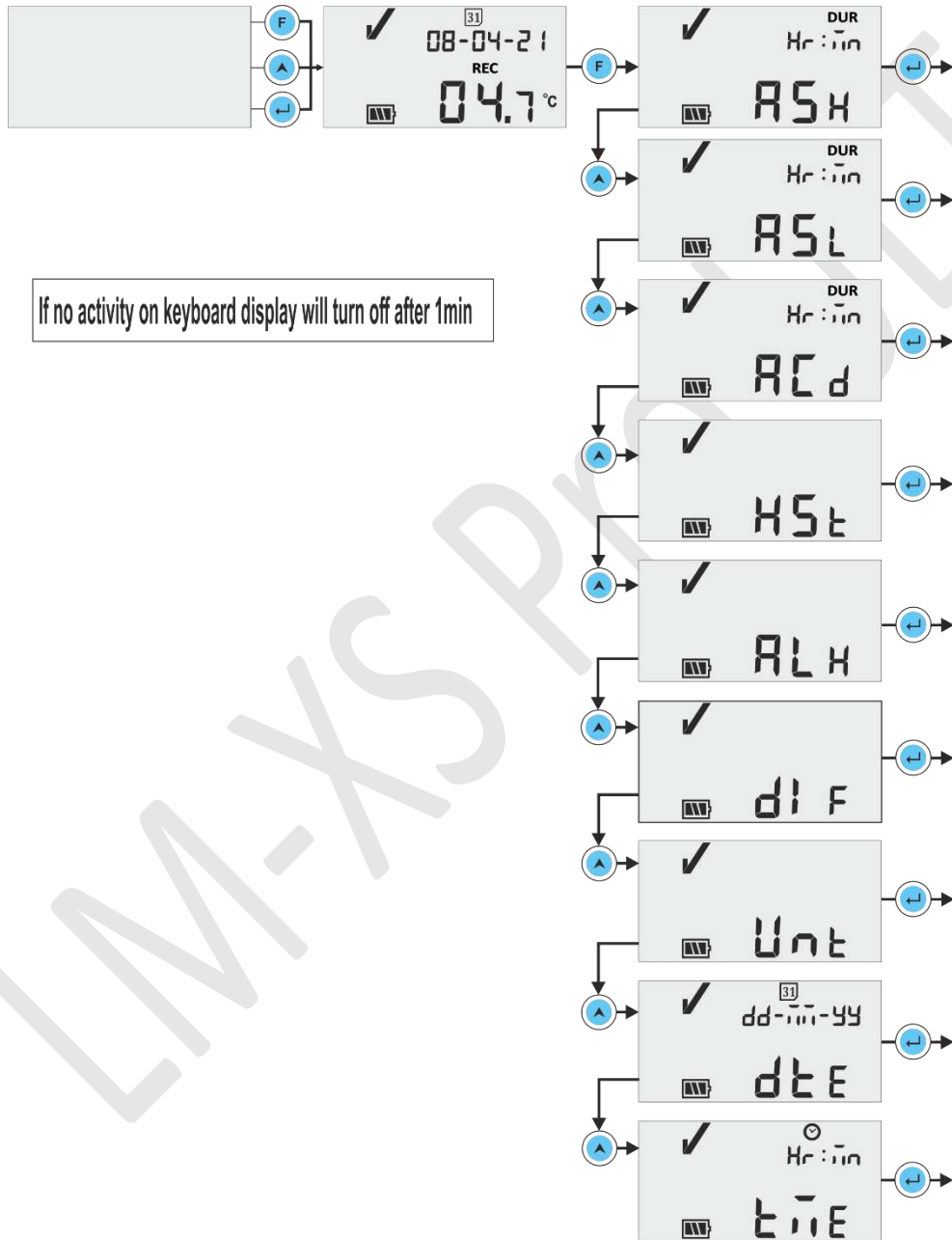

Figure 10 Main Menu Sequence

6.4.1 ASH (Alarm Set Point High)

In this menu, Alarm setpoint High along with its alarm delay can be seen, which is **Preset at +8°C and 10 hours**. **User can only view this parameter.**

Alarm ON Time duration for Setpoint High is in HR:MN#. This is the time required for the reading to remain more than ASH, to be treated as alarm.

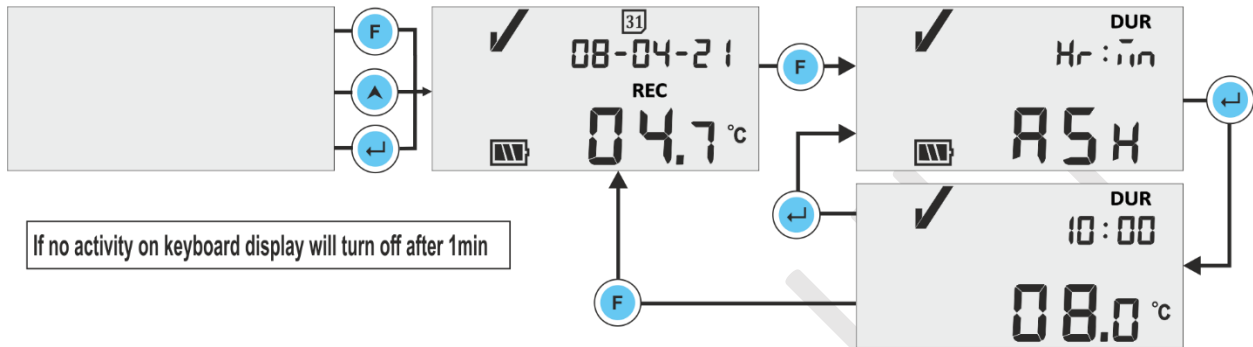

Figure 11 Alarm Set Point High

6.4.2 ASL (Alarm Set Point Low)

In this menu, Alarm setpoint Low along with its alarm delay can be seen, which is **preset at -0.5 °C and 1 hour**. **User can only view this parameter.**

Alarm ON Time duration for Setpoint Low is in HR:MN#. This is the time required for the reading to remain more than ASL, to be treated as alarm.

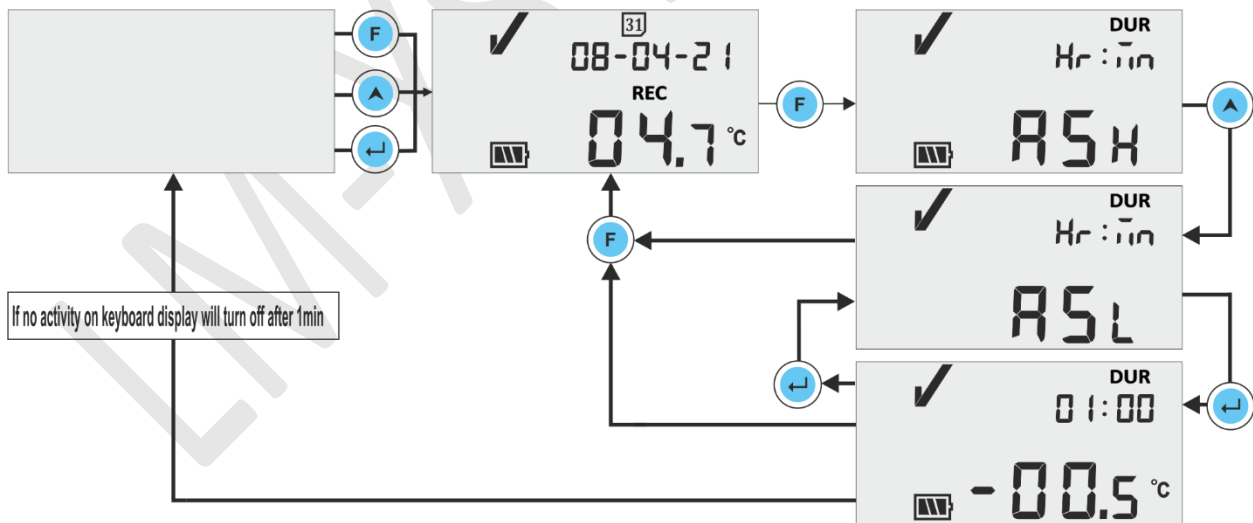

Figure 12 Alarm Set Point Low

In alarm high/low condition after Alarm ON High/ Low delay, the buzzer will be activated for 1 sec at every 1 hour interval. For detailed buzzer operation refer [section 6.7](#).

6.4.3 ACD (Alarm Acknowledge Delay)

If the alarm condition persists for more time, user can deactivate the buzzer by acknowledging it. The alarm can be acknowledged by pressing “Function” and “Enter” key simultaneously. The buzzer will be deactivated for Alarm acknowledge delay time.

Alarm acknowledge Delay time is preset with 1 hour. The user can read alarm acknowledgement delay by following the sequence shown in figure 13.

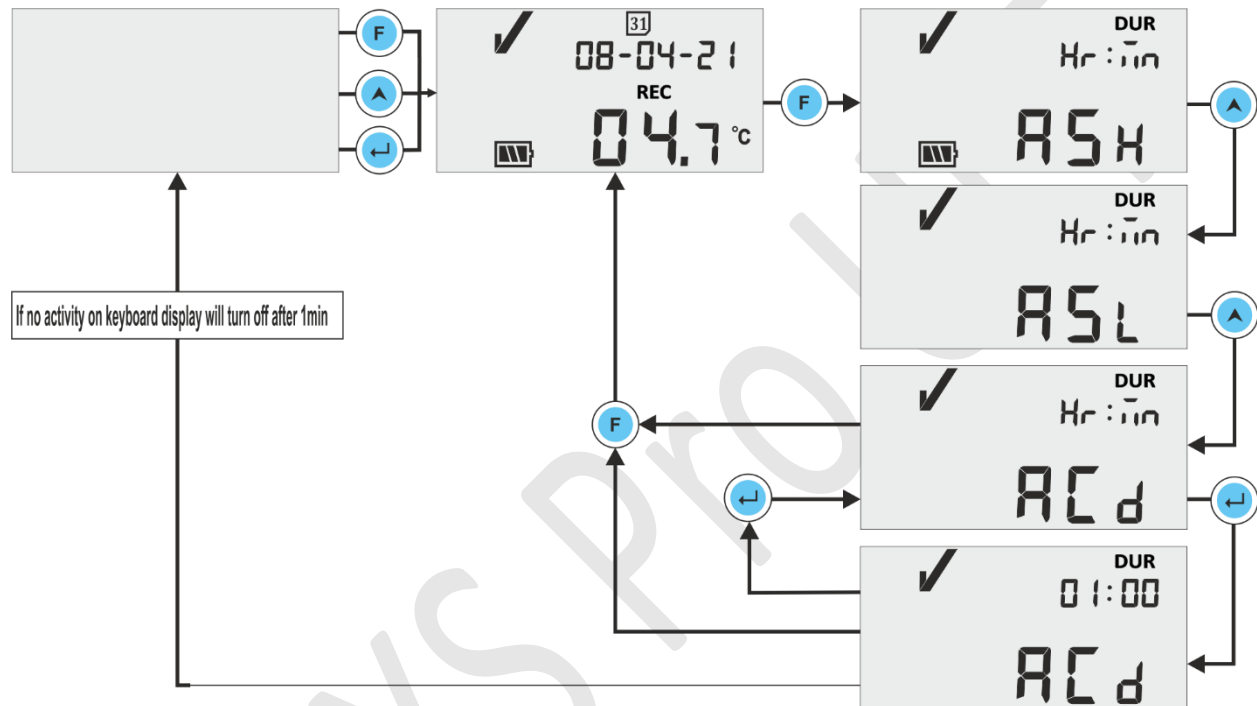

Figure 13 Alarm Acknowledge Delay

ASH, ASL and ACD are Preset and range for HR and MN is 00 to 23 and 00 to 59, respectively.

6.4.4 HST (History Menu)

The user can see the history data of min/max values for last 30 days using history menu. In this menu, the user can choose the history days option from 01 - 10, 11 - 20 and 21 - 30 days as shown in figure 14.

Note:

- History menu terminates automatically if the data is not available to display.
- E.g., If we started the data logger just before 3 days, then history data should be shown only for last 3 days and History menu terminates followed by showing current temperature.
- If the data logger is started less than 24 hours back, History menu gets terminated without showing any min/max data, as there is no history data to be displayed.

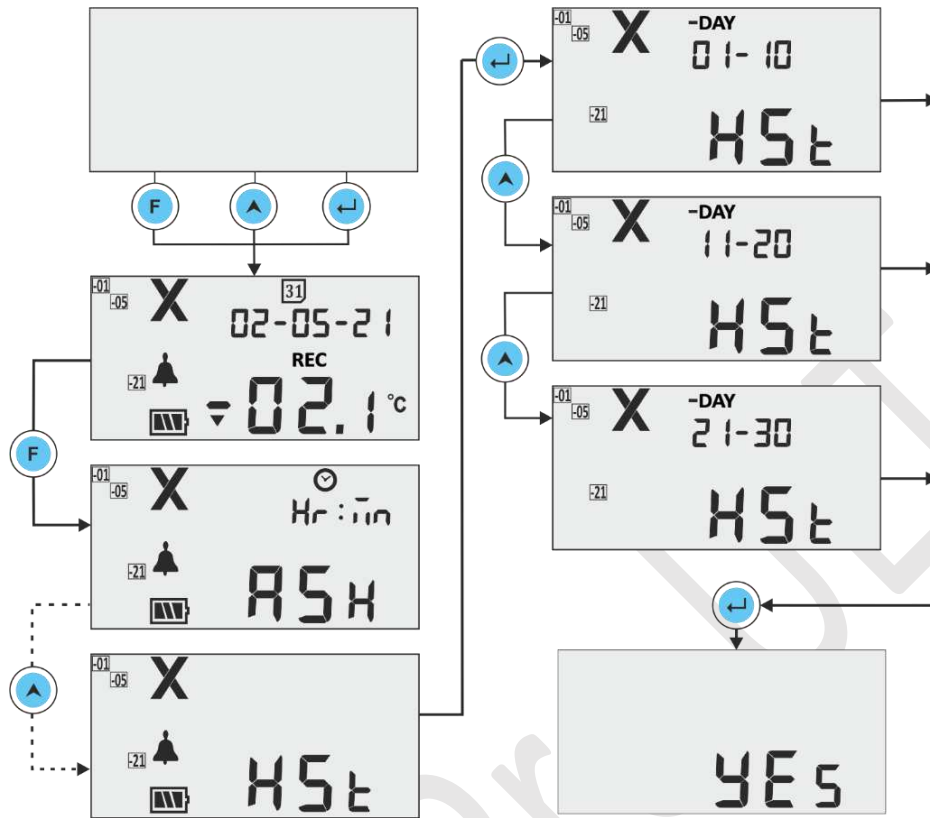

Figure 14 History Menu to view Min/Max Temperature

Example: If the user chose 01 - 10 days option, then the display will be showing the date of “-01” day, alarm trigger time (In case of alarm), history data for Min & Max values along with its duration and sensor open/broken condition duration (if any) in sequence up to last 10 days with approx. 3 sec time intervals as follows:

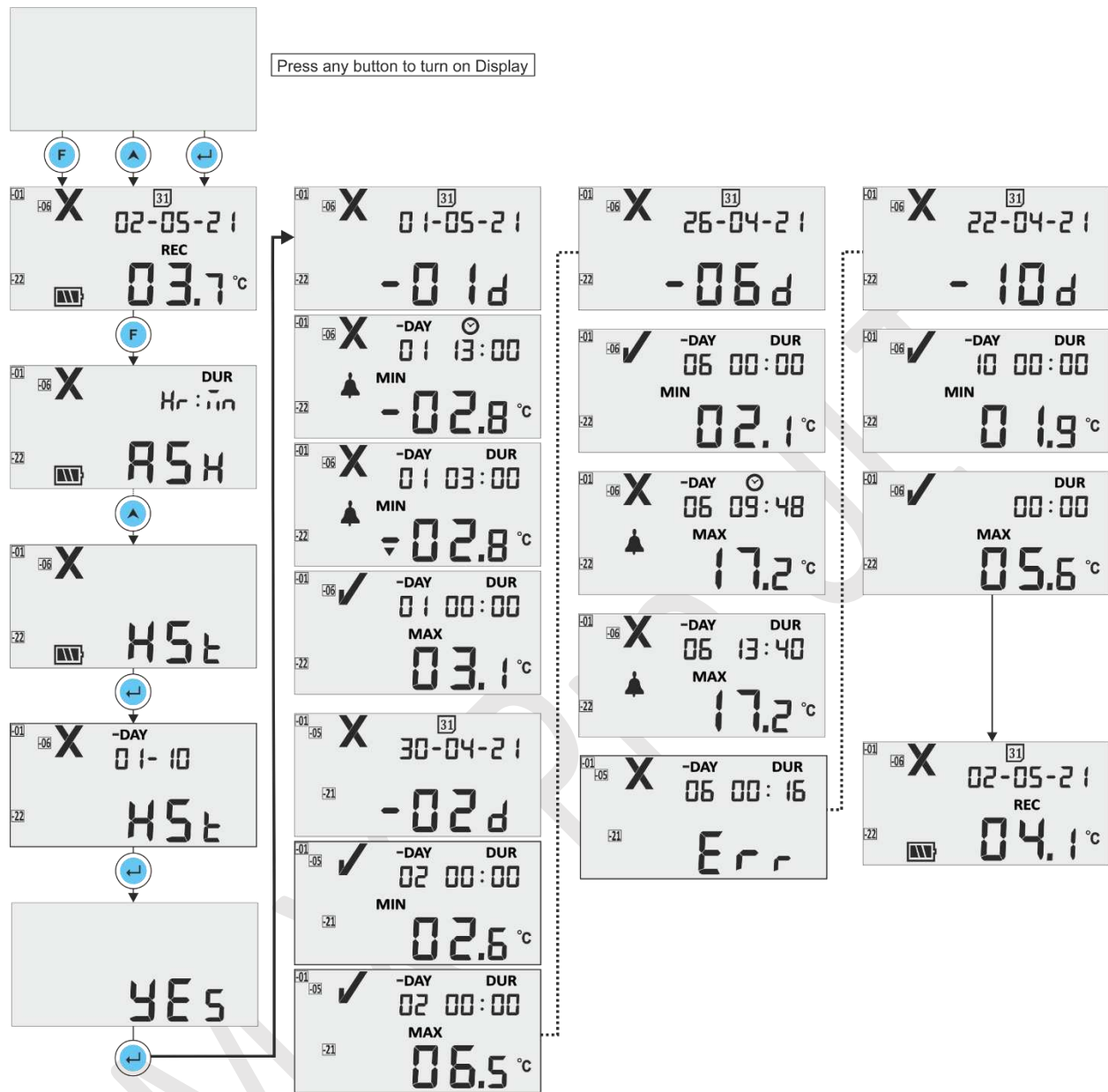

Figure 15 View History data Sequence for 01 to 10 days

6.4.5 ALH (Alarm History View)

If the user wants to view only alarm data in last 30 days history, it can be seen using Alarm History View (ALH) option by following the sequence shown in figure 16. Here, the parameters display sequence is same as history data view menu, except that its only showing history with alarms. Alarm History view terminates automatically if there is no alarm data to show in last 30 days.

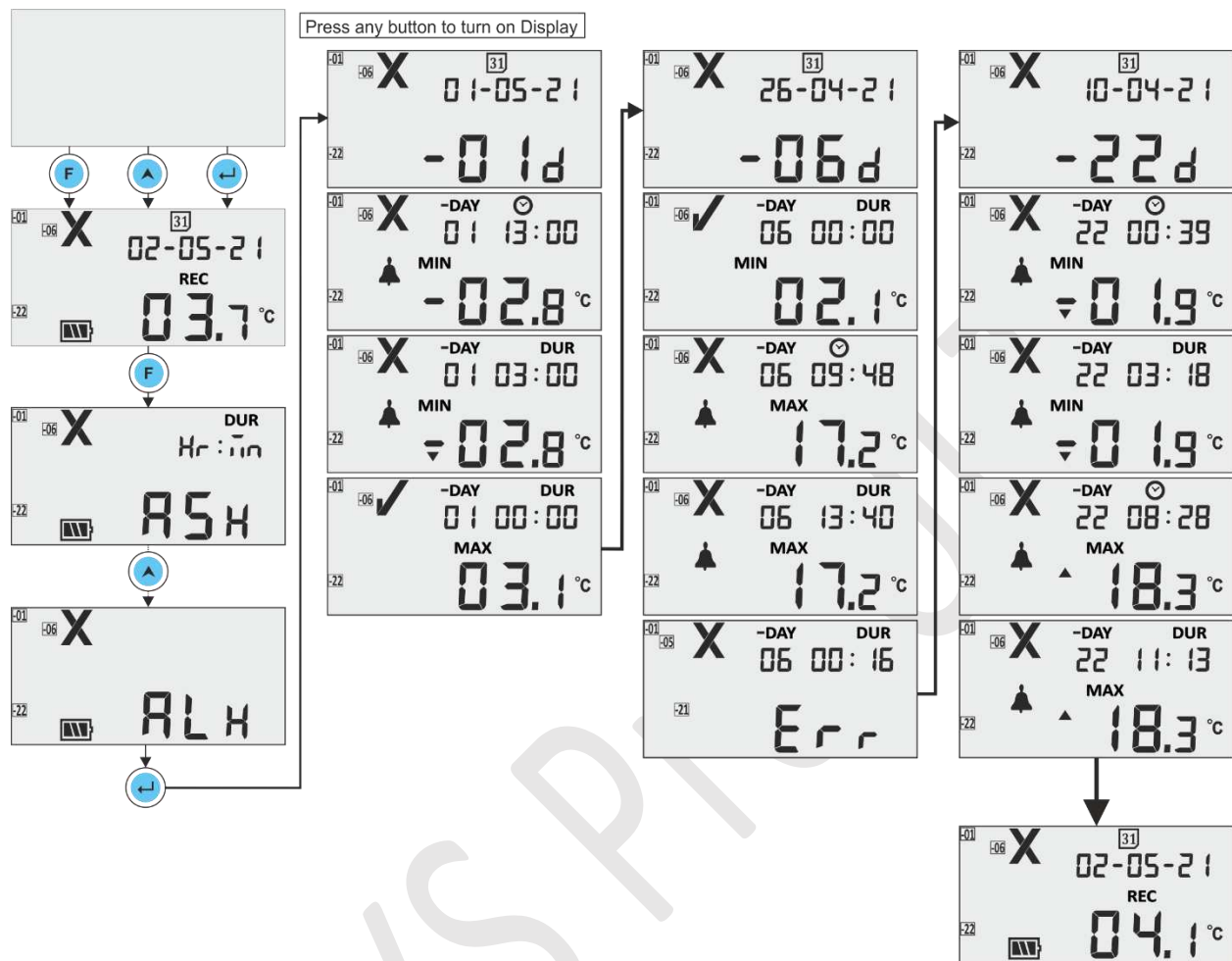

Figure 16 View Alarm History data in last 30 days

Note: Normal history and Alarm history viewing can be terminated manually by pressing “Up” and “Enter” keys simultaneously.

6.4.6 DIF (Device Information)

The user can view device information using this option in menu. The device information consists of serial number, version number and CRC checksum for the LM-XS^{Pro} ULT data logger, which can be read as shown in figure 17(The numbers shown are for example purpose only).

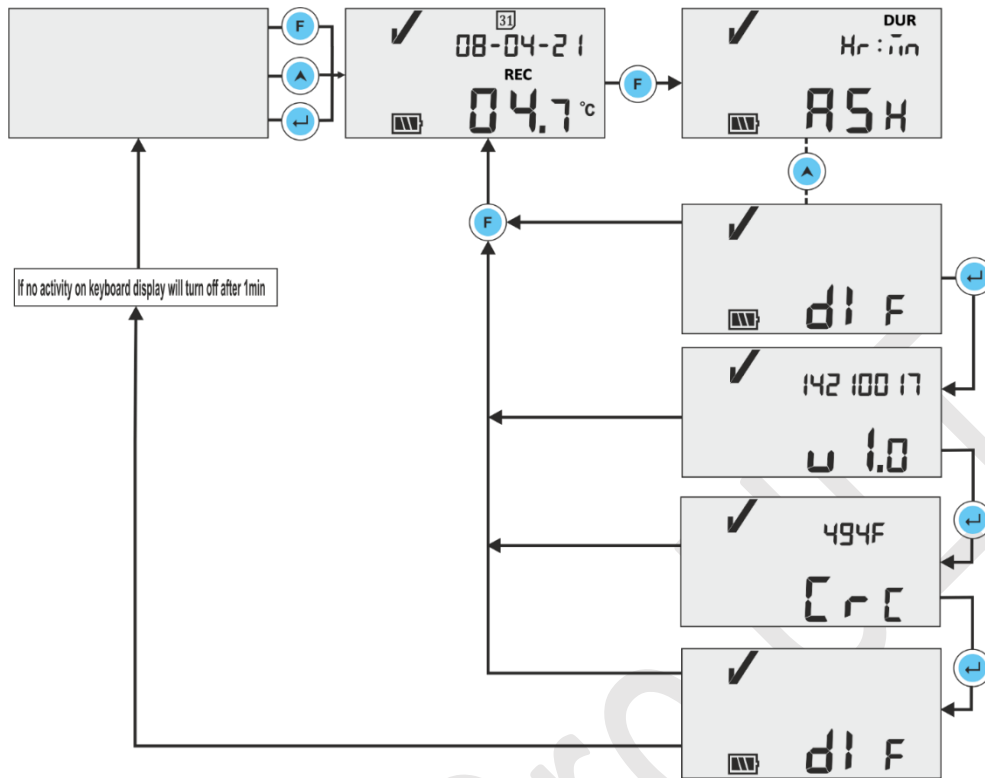

Figure 17 View Serial No., Version No. and CRC

6.4.7 UNT (Unit)

In this menu, user can select Temperature unit – “CEL” (°C) / “FAH” (°F) for viewing by following the steps shown in figure 18. User can view the data in degree Fahrenheit, but data is stored in degree Celsius only.

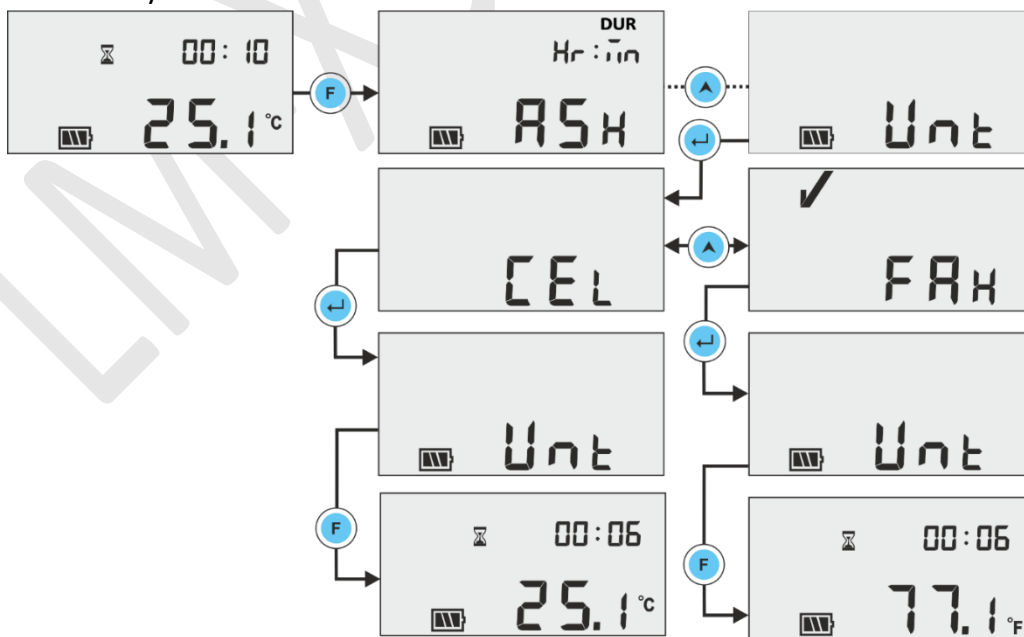

Figure 18 Select Unit for Temperature reading

Note: The report will show the data in last selected unit. The default set unit is degree Celsius.

6.4.8 DTE (Date setting)

The date can be adjusted using date setting menu as shown in figure 19. Date can also be set/changed while data logger is running. **Date can be changed as many times in a day as user wants but the last date changed will only be stored.**

In history data also the last date changed will be displayed. Every time date is changed a date change Tag is logged and it can be seen by downloading the data using LMViewXS-E006 software application.

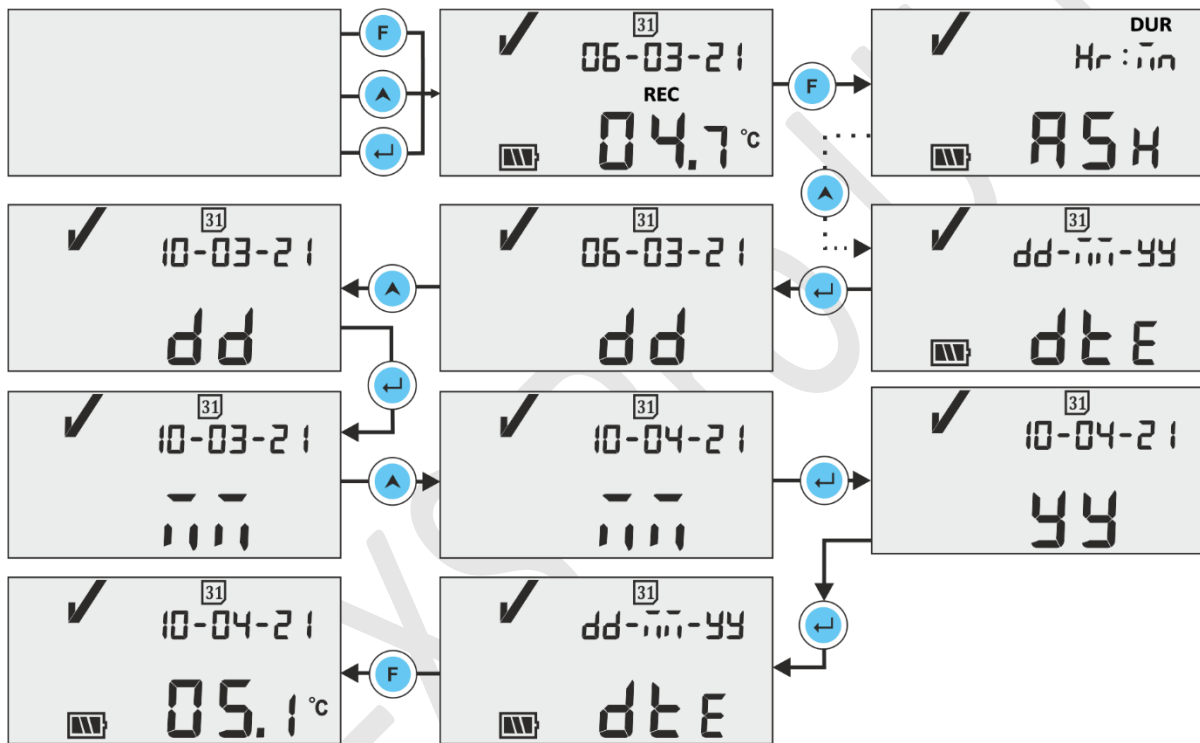

Figure 19 Date setting menu in dd-mm-yy format

6.4.9 TME (Time setting)

The device time can be adjusted using time setting menu as shown in figure 20. Time can also be set/changed while data logger is running. All changes in time are logged in memory as Tag and it can be seen by downloading the data using LMViewXS-E006 software application.

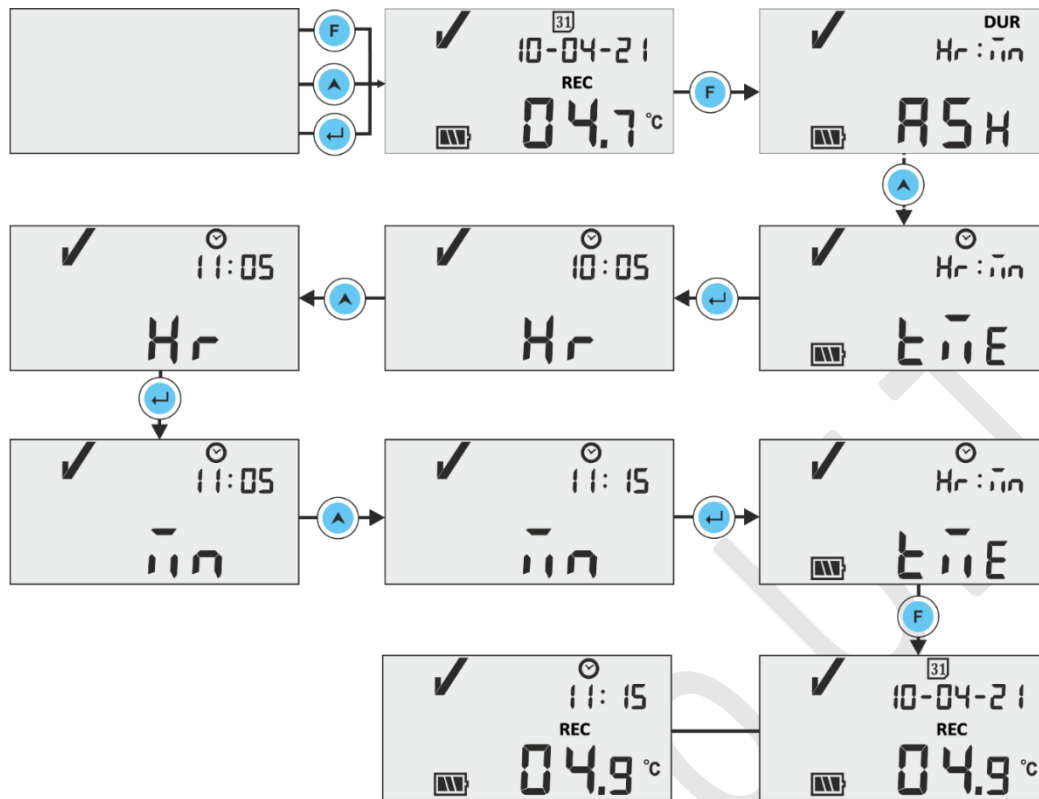

Figure 20 Time setting menu

Note: Date and Time settings are logged as Tag event in data records. Here, Blinking Segments indicates current selection.

6.5 Measurement

Starting Measurement

With Default Configuration of the LM-XS^{Pro} ULT data logger, the measurement program will be started automatically after 10 minutes of device RTC set on power up. The Configuration parameters are prefixed as per **WHO Specification reference E006/TR06.3 Issue date September 8, 2010**, and user cannot change them from device menu.

- The data logger switches to recording mode showing “REC” message on display and “RUN” LED flashing.
- Temperature Data is logged at prefixed logging interval of 5 minutes.

Tag Events

- When alarm high / low condition occurs in temperature measurement, a special Tag event with time stamp is logged in data records.

- Tag event is logged again when alarm high/low condition is restored in temperature measurement.
- When Date is set a special tag event with time stamp is logged in data records.
- Time setting Tag event is logged when the user adjusts the time in device running condition.
- If sensor is broken or not inserted properly, tag event is logged as sensor open.
- When the user has paused the data logging, pause event is logged and after 15 minutes Start after pause event is logged.

Tag ID	Tag Event	Description
D	Date Set	User has set the date.
E	Sensor Open	Sensor open or broken (Reading goes beyond specified temperature range for the sensor)
A	Alarm Triggered	Alarm high/low condition has occurred.
R	Alarm Reset	Alarm high/low condition is restored.
T	Time set: old time Hr: Mn	User has updated the current time.
P	Pause Data	User has paused data statistics of alarm, min/max for 15 minutes.
S	Resume From Pause	Normal recording is resumed after 15 minutes.

Note: Number of data records get reduced according to number of Tag data events. Tag Event(s) can be seen in software application and generated pdf report after downloading data.

6.6 Displaying of Reading in Normal and Alarm Condition

There are four possible circumstances of displaying temperature reading for data logger:

- 1) Reading is within the set point high/ low.
 - OK sign, battery, reading and unit will be seen on display.

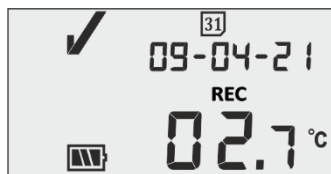

- 2) Reading is outside the setpoint high/ low for time less than alarm high/low delay.
 - OK sign, battery, reading with UP/ Down arrow and unit will be seen on display.

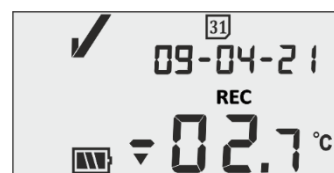
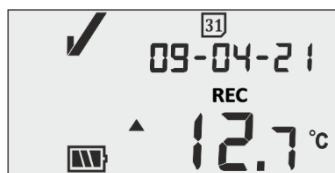

- 3) Reading is outside the setpoint high/low for time greater than alarm high/low delay.
- Alarm sign, bell sign, battery, reading with UP/ Down arrow and unit will be seen on display.

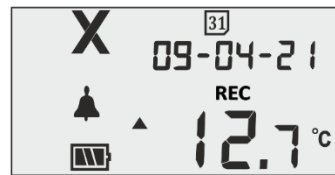
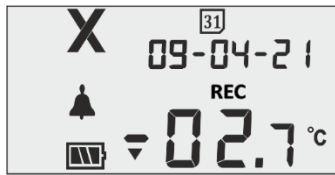

- 4) Reading is outside the setpoint high/low for time greater than alarm high/low delay with Alarm acknowledged by pressing “Function” and “Enter” key.
- Alarm sign, battery, bell symbol, reading with UP/ Down arrow and unit will be seen on display Buzzer will be deactivated for alarm acknowledgement delay (1 hour).
 - Alarm sign, “ALA” (Alarm Acknowledged) message will be seen on display for 3 sec.



6.7 Buzzer Operation

- Buzzer will be activated in following conditions:

- 1. Alarm High/Low:** In case, temperature goes beyond alarm set point high/low, after alarm delay high/low, buzzer will be activated for 1 sec at every 1 hour interval. If alarm condition persists buzzer activation will continue for 15 hours, after that buzzer will be deactivated until temperature gets restored in normal range and alarm condition occurs again.
- 2. Sensor Open:** When sensor is open or not inserted properly, device display will show “SnC” message and buzzer will be activated for 1 sec within 5 minutes. If sensor open condition persists, buzzer will be activated for 1 sec at 15 minute interval for four times, then buzzer will be deactivated, display will be turned on, NOK symbol and Sensor open message will remain on display only.

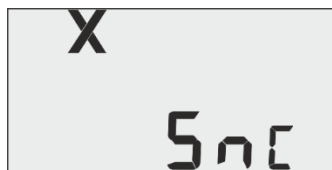

3. **Sensor Broken:** When sensor cable is broken or the reading goes out of device temperature range, device display will show “Err” message on the device display. Buzzer operation will be same as described in Sensor Open condition, except showing “Err” message on display.



6.8 Paused Function

- The Pause function is useful, for example, when you wish to temporarily remove the sensor from the monitored location to inspect goods, but you do not wish to trigger an alarm due to your handling.
- This allows the user to review the current statistics or clear an alarm without causing a false alarm or statistic while handling the data logger.
- The data logger is configured to halt processing of temperature data for alarms and min/max statistics for a period of two/ three temperature reading after paused function is activated by pressing “Function” and “UP” key for 5 seconds. This will be indicated by “PAUSE” message along with pause time counter and sand clock on the display.
- Prefixed Pause time for the data logger is 15 minutes. After pause time out, the data logger will resume to normal operation, “PAUSE” message will disappear, and “REC” will be displayed.



- If sensor is open/ broken during the pause delay, “SNC” or “Err” message will be seen on the display along with pause time counter and message.
- **If the data logger is in alarm condition and user has paused the logging, then the pause time is excluded from the alarm trigger time and duration calculation.**

6.9 Reading out Data

6.9.1 Connecting with the Software Application

Displaying a measurement data report

- Connect the LM-XS^{Pro} ULT data logger to Windows PC via the USB Type-A port as shown in figure 21.
- After connecting the data logger with PC, display remains ON and it shows USB port symbol along with the other values.

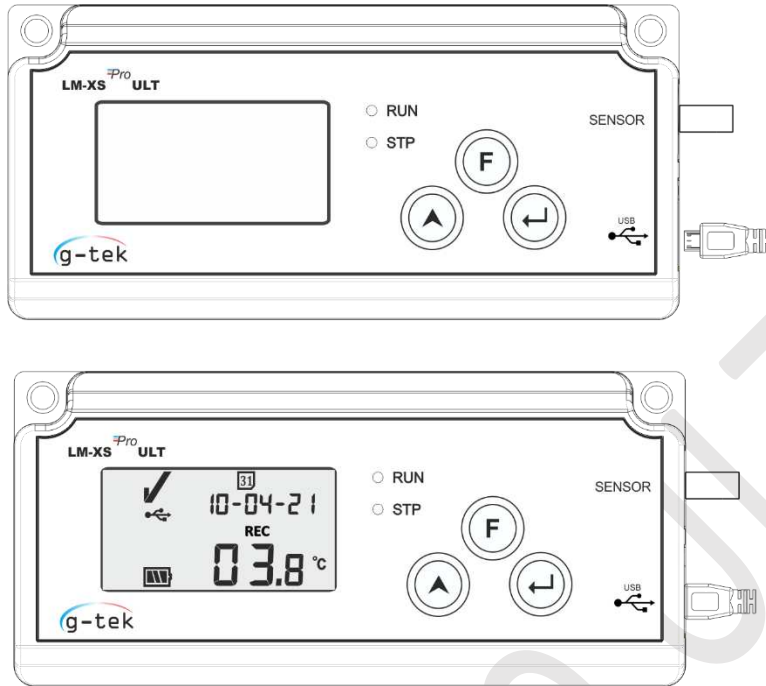

Figure 21 Micro USB Attachment

6.9.2 Generating PDF report

- Open LMViewXS-E006 software Application to carry out analysis for process readings. The pop up window will appear as shown in figure 22. Select the appropriate file path and batch file name for saving the data summary and press button.

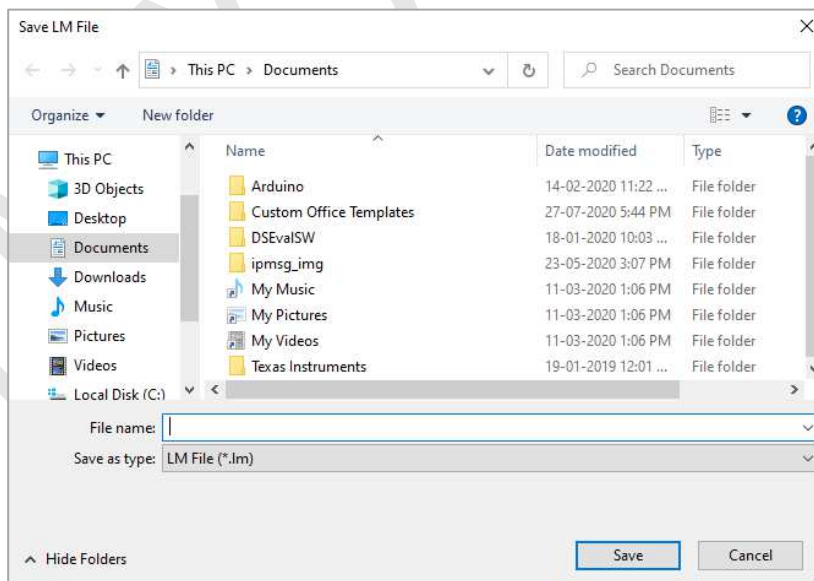



Figure 22 Selecting file location for saving data summary

- Downloading of data will be completed after some time and downloaded data can be seen in tabular form as shown in figure 23.

Batch name : G-TEK CORP Number of readings : 326 Timezone : (UTC+05:30) Chennai, Kolkata, Mumbai, New Delhi

Sr.No	Date And Time	25210018 Temperature (C)	Remarks
1	04-02-21 12:10	28.6	-
2	04-02-21 12:15	28.6	-
3	04-02-21 12:20	28.5	-
4	04-02-21 12:25	28.3	-
5	04-02-21 12:30	28.3	-
6	04-02-21 12:35	28.3	-
7	04-02-21 12:40	28.3	-
8	04-02-21 12:45	28.3	-
9	04-02-21 12:50	28.2	-
10	04-02-21 12:55	28.1	-
11	04-02-21 13:00	28.1	-
12	04-02-21 13:05	27.9	-
13	04-02-21 13:10	28.0	-
14	04-02-21 13:15	28.1	-
15	04-02-21 13:20	28.3	-
16	04-02-21 13:25	28.3	-
17	04-02-21 13:30	28.4	-
18	04-02-21 13:35	28.3	-
19	04-02-21 13:40	27.8	-
20	04-02-21 13:45	27.4	-
21	04-02-21 13:50	27.3	-
22	04-02-21 13:55	27.3	-
23	04-02-21 14:00	27.2	-
24	04-02-21 14:05	27.2	-
25	04-02-21 14:10	27.2	-
26	04-02-21 14:15	27.5	-
27	04-02-21 14:20	27.6	-
28	04-02-21 14:25	27.7	-
29	04-02-21 14:30	27.8	-
30	04-02-21 14:35	27.9	-
31	04-02-21 14:40	28.0	-
32	04-02-21 14:45	28.0	-
33	04-02-21 14:50	28.1	-
Minimum	--	05-02-21 13:35	0
Maximum	--	05-02-21 09:15	28.1

Figure 23 Downloaded data summary

- After that and generate the PDF report of data summary by clicking on  icon. A pop up window will appear for selecting the file path and filename of report to be generated as shown in figure 24.

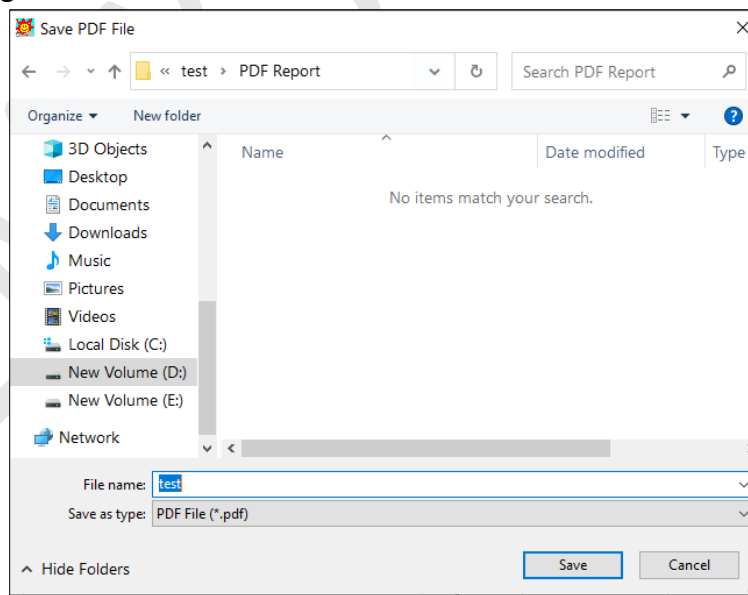

Figure 24 Selecting file location for saving PDF report

6.9.3 PDF Report Explanation

➤ Sample PDF file generated from LM-XS^{Pro} ULT Data logger for 3 days recorded data is shown in figure 25, figure 26 and figure 27. This report consists of following data:

1. Title of the report generated – Prefixed title
2. Device Information – Shows device identification details
3. Batch Information – displays Prefixed alarm settings & store interval; device activation, batch start and report generation date and time with time zone
4. Logged Data Summary – consists total data points captured, starting and last record time
5. Statistical Summary – Statistical analysis of the total logged data
6. Data Summary – Shows max 120 days summary in table; Each row consists of a day summary:
 - Date: Entry of date is in **ascending order**
 - Events: Date set, Time set
 - Average Temperature for the day
 - Lower Alarm Limit: Min Temperature with its alarm low trigger time and cumulative time
 - Upper Alarm Limit: Max Temperature with its alarm high trigger time and cumulative time
 - Sensor Connection Error: Alarm trigger time and its cumulative time for the day
 - Alarm Status: OK / ALARM
 - Signature/Remarks/Action taken
7. Graph for the logged data –Graph for temperature data versus date and time; Title indicates date span for logged data

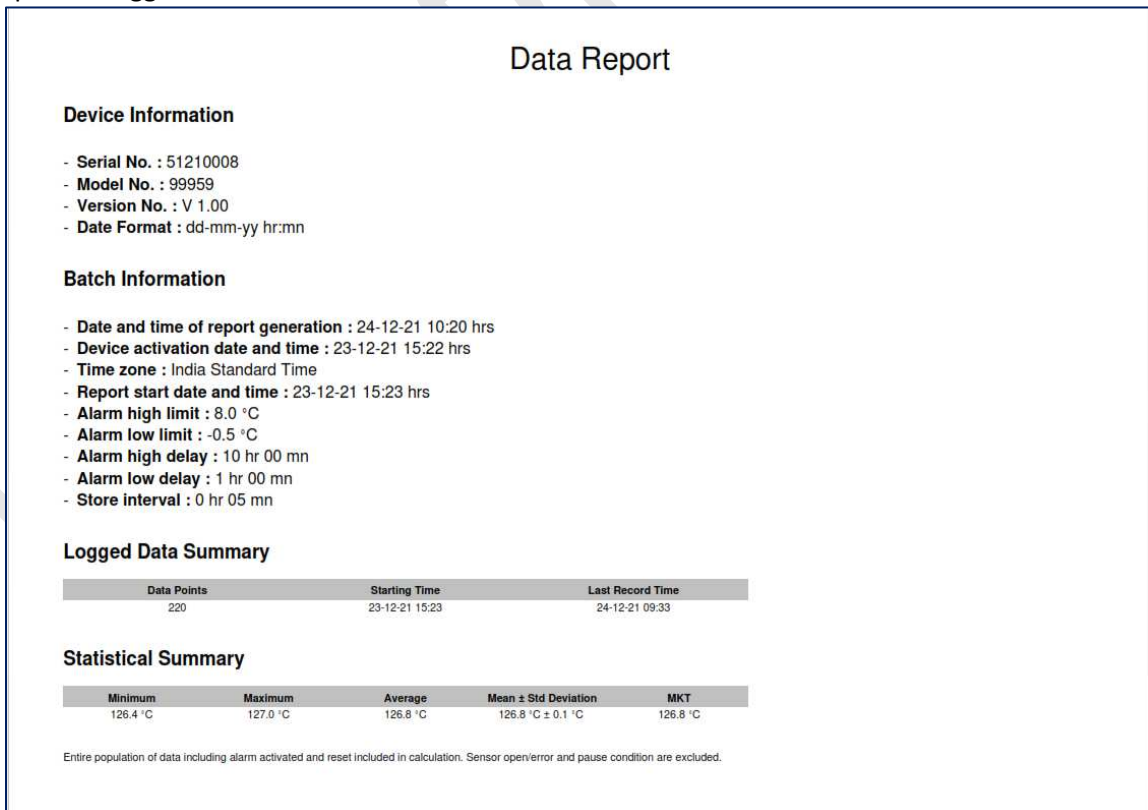

Figure 25 Sample PDF report part -1

Data Summary

No.	Date	Events	Lower Alarm Limit				Upper Alarm Limit				Sensor Connection Error		Alarm Status	Signature / Remarks / Action taken
			Average Temperature	Minimum Temperature	Cumulative Time	Alarm Trigger Time	Maximum Temperature	Cumulative Time	Alarm Trigger Time	Cumulative Time	Alarm Trigger Time			
1	23-12-21	-	126.6 °C	126.4 °C	-	-	126.8 °C	8 hr 37 mn	-	-	-	-	ALARM	
2	24-12-21	-	126.9 °C	126.8 °C	-	-	127.0 °C	9 hr 33 mn	01:23 hr	-	-	-	ALARM	

D = date changed, dd-mm-yy; T = time changed, hr:mn (old value, new value);

Figure 26 Sample PDF report part -2

- This sample data summary shows:
 - Events for date and time change tags;
 - Alarm high trigger time and its cumulative time
 - Sensor connection error trigger time and cumulative time

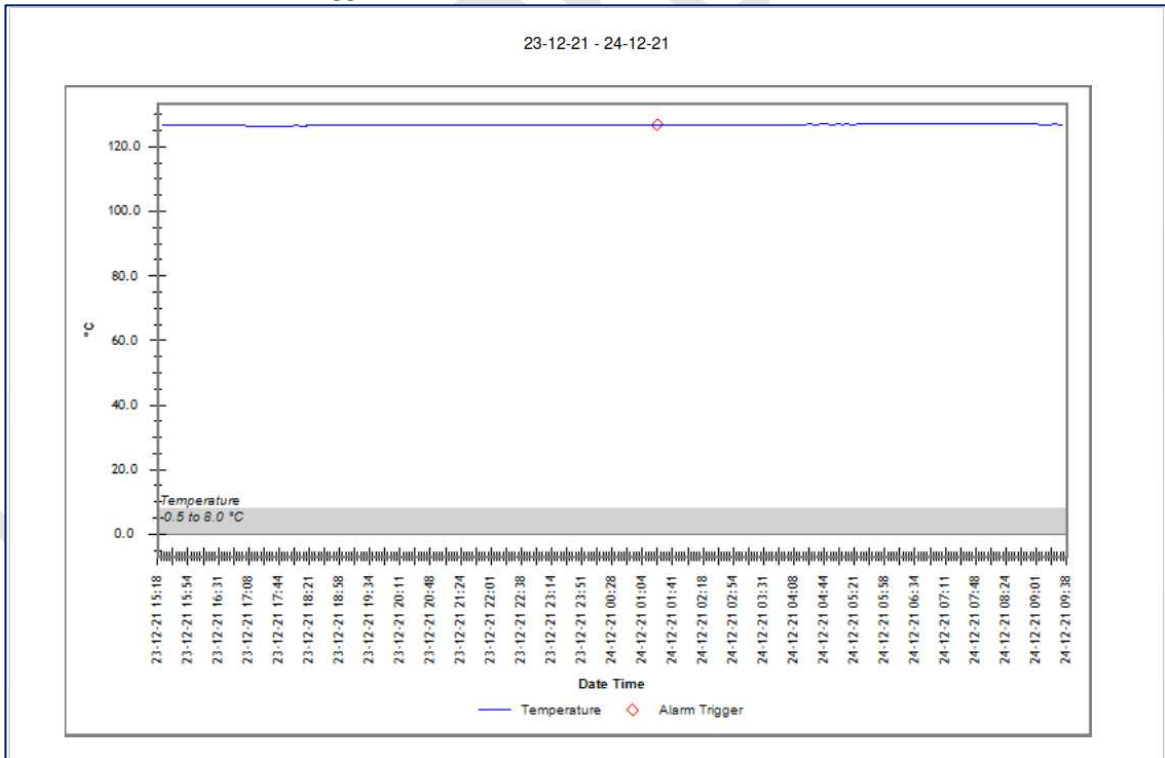

Figure 27 Sample PDF report part -3

- The gray band in graph shows area inside alarm low and high limit. Indications for alarm trigger, alarm restore, sensor connection error are specified in graph labels as shown in figure 27.

6.9.4 Definition of Important Terms in PDF Report

1. **MKT (Mean Kinetic Temperature):** It is a simplified way of expressing the overall effect of temperature fluctuations during storage or transit of perishable goods. In other words, MKT is a calculated, single temperature that is analogous to the effects of temperature variations over a period.
2. **Mean \pm Std Deviation:** The mean and the standard deviation of a set of data are usually reported together. A low std deviation indicates that the data points tend to be remarkably close to the mean; a high std deviation indicates that the data points are spread out over a broad range of values.
3. **Cumulative time:** Actual[#] cumulative daily time duration for below/above the temperature limit.
4. **Alarm Trigger time:** Time at which alarm high/low triggers after corresponding alarm delay.

Date and time change have no effect on alarm records. E.g. Alarm high trigger time for the given day is 17:30 hr and the user has changed the current time from 18:00 hr to 23:30 hr. In this case, the cumulative time for the alarm will be 00 hr 30 mn.

Note: Refer the help menu for detailed description of data analysis in LMViewXS-E006 software application.

7 MAINTAINING THE PRODUCT

7.1 Accessories

- Sensor cable
- USB cable
- Sensor and Device calibration certificates

7.2 Cleaning the Data Logger

Ensure that no liquid enters inside the housing.

- If the housing of Data logger gets dirty, clean it with damp cloth.
- Do not use any aggressive cleaning agents or solvents.
- When USB port is not in use, cover the USB port properly.

7.3 Battery

- The LM-XS^{Pro} ULT data logger contains a Lithium Battery. The end of the battery life is indicated by a low battery symbol, the data logger should be replaced within 15 days when this symbol appears.
- Dispose or recycle the battery in accordance with your local regulations.
- Do not expose the Data Logger to extreme temperatures as it may lead to the destruction of the battery and may cause injuries.

“Warning, Battery may explode if mistreated. Do not recharge, disassemble or dispose of in fire.”

8 TIPS AND ASSISTANCE

Table 4 Frequent Asked Questions (FAQs)

Questions	Possible Cause/ Solution
"STP" LED does not Flash.	<ul style="list-style-type: none"> Device might be in Sleep Mode or "RUN" Mode. Device date and time are not set by user.
How to change the date format?	<ul style="list-style-type: none"> On power up condition, user can select the date format. After selection it cannot be altered in data logger. The default format is dd-mm-yy.
When to set the RTC in Device?	<ul style="list-style-type: none"> After device activation, at power up condition it is required to set the RTC. User can also adjust the RTC from main menu options.
Device is not connected in software application.	<ul style="list-style-type: none"> USB Symbol must be shown on Display. During insert of USB cable, "STP" and "RUN" LEDs Flash together. Try to reconnect Micro USB data cable. Micro USB cable might be faulty. Replace the cable. In case of USB Type C port, use USB Type C to Type A female cable for connecting the device.
Display Shows "SnC" message.	<ul style="list-style-type: none"> Sensor cable might not be inserted properly.
Display Shows "Err" message.	<ul style="list-style-type: none"> Sensor cable might be broken or temperature is out of measuring range.
What happens if Sensor is not connected after device wake up?	<ul style="list-style-type: none"> Recording of temperature will be delayed by the time for which sensor is not connected. <p>E.g., Once device wake up and RTC set, delay counter starts. If sensor is removed from data logger, within 5 min "SnC" message is displayed and delay counter shows 00:05(Hr: Mn). If sensor is connected after 10 minutes, then delay counter resumes from the last count and the recording is delayed by 10 minutes.</p>
For how much time, the display remains ON after device activation?	<ul style="list-style-type: none"> Once the device is activated, the display remains ON for 10 minutes, then it will off. The display is normally off to save the battery life when no activity on device.
How to set the time of device if it has offset from local time?	<ul style="list-style-type: none"> User can adjust the time using "tME" menu (section 6.4.9).
How to set the date of device if it has offset from local date?	<ul style="list-style-type: none"> User can adjust the time using "dtE" menu (section 6.4.8).
What are the conditions for buzzer activation?	<ul style="list-style-type: none"> Please refer the Buzzer operation conditions in section 6.7.
How to deactivate the Buzzer for some time in continuous alarm condition?	<ul style="list-style-type: none"> Buzzer can be deactivated by pressing "Function" and "Enter" key at same time for alarm acknowledgement delay.
How to activate pause function?	<ul style="list-style-type: none"> Press "Function" and "Up" key for 5 sec simultaneously to activate the pause function. (Refer section 6.8 for details)
What to do if user wants to view updated temperature quickly on display, after changing the temperature?	<ul style="list-style-type: none"> User can press "Up" and "Enter" key simultaneously for 3 to 4 times to get quick update view of temperature reading.