

OPERATING MANUAL

CR-2010^{Pro}

CR-2010 Pro Series 4" Circular Chart Recorder Model No.:1xx00



Manufacturers of :

- Circular Chart Recorders
- Inkless Recorders
- Paperless Recorders
- Scanners & Data Loggers
- Networked Data Loggers
- Application Software
- WHO PQS Qualified Data Loggers
- Vaccine Series Data Loggers

G-TEK CORPORATION PVT. LTD.

"Gunaji House"
Plot No. 25/1, Besides Status Bungalow,
Padra Road, Vadodara – 391410.
tel.: +91-98245 24140
e-mail: info@gtek-india.com
url: www.gtek-india.com

► Congratulations

Thank you for choosing G-Tek Recorders for your recording needs.

The all new updated CR2010 series of recorders owes much to the user feedback. While maintaining the ease of operation of CR2010, the efforts have been made to further simplify the operation and improve overall look and feel. The recording range, chart speed, and calibration factors are all user programmable from the front panel key-board. Polynomial based linearization for most of the known inputs, along with high resolution a/d makes it one of the high accuracy recorders in its category. A universal input version offers field selection of sensor types. The mechanical and electrical designs have been optimized for ruggedness and ease of operation. These instruments will undoubtedly prove to be a valuable asset at your plant.

Before installing and operating the instrument, please take time to go through the manual, which will enable you to get the most out of your recorder.

Our new series owes much to the feedback received from our customers, and we shall always welcome your suggestions and comments on any aspect of our products.

g-tek corporation

vadodara

▶ Calibration Accuracy

This product was thoroughly tested to ensure compliance with the published specifications. G-Tek further certifies that all instruments used in production and final test are regularly inspected to maintain accuracy of calibration and are traceable to the National or International standards, to the extent allowed by that organization's calibration facility, and to the calibration facilities of other International Standards Organization members. The user should be satisfied that the performance of the product as received meets expectations and, as part of a program of planned maintenance, should periodically check calibration accuracy against reliable standards.

Copyright © 2009:

G-Tek Corporation (G-Tek) All rights reserved.

▶ Warranty

This product is warranted against defects in materials and workmanship for a period of one year from the date of shipment. During the warranty period, G-Tek will, at its option, either repair or replace products which prove to be defective.

▶ Warranty Service

Warranty service at the buyer's facility can be provided only under prior agreement by the manufacturer or its representative, and the buyer may be required to pay round-trip travel expenses. In all cases, the buyer has the option of returning the product for Warranty service to a facility designated by the G-Tek or its representatives. The buyer shall prepay shipping charges for products returned to a service facility, and the G-Tek or its representative shall pay for the return of the product to the buyer. However the Buyer shall pay all the shipping charges, duties and taxes for products returned to G-Tek from outside of Vadodara, India.

▶ Limitation of Warranty

The foregoing warranty shall not apply to defects arising from: Improper or inadequate maintenance by the buyer, Improper or inadequate site preparation, Unauthorized modification or misuse, Operation of the product in unfavorable environments, especially, high temperature, high humidity, corrosive or other damaging atmospheres. In addition, G-Tek does not warrant any damage that occurs as a result of the Buyer's circuit or any defects that result from Buyer-supplied products.

▶ Exclusive Remedies

The remedies provided are herein the buyer's sole and exclusive remedies. G-Tek shall not be liable for any direct, indirect, special incidental or consequential damages (including lost profits) whether based on warranty, contract, tort, or any other legal theory.

▶ Disclaimer





G-Tek makes no other warranty expressed or implied, whether written or oral with respect to this product and specifically disclaims any implied warranty or condition of merchantability, fitness for a particular purpose or satisfactory quality.

▶ Notice

The information contained in this document is subject to change without notice. G-Tek Corporation makes no warranty of any kind with regards to this material, including, but not limited to, the implied warranties of merchantability and fitness for a particular purpose. G-Tek Corporation shall not be liable for errors contained herein or for incidental or consequential damages in connection with the furnishing, performance, or use of this material. No part of this document may be photocopied, reproduced, or translated to another language without the prior written consent of G-Tek.

► Symbol Definitions

The following table lists those symbols used in this document to denote certain conditions.

	This caution symbol on the equipment refers to the user to the Product Manual for additional information. This symbol appears next to the required information in the manual.
	Warning Personal Injury : Risk of electrical shock. This symbol warns the user of a potential shock hazard where HAZARDOUS LIVE voltage greater than 30 Vrms, 42.4Vpeak or 50Vdc may be accessible. Failure to comply with these instructions could result in death or serious injury.
	Attention Electrostatic Discharge (ESD) hazards. Observe precautions for handling electrostatic sensitive devices.
	Protective Earth Terminal. Used for non-safety purpose such as noise immunity improvement. NOTE : This connection shall be bonded to protective earth at the source of supply in accordance with national local electrical code requirements.
	Earth Ground. Functional earth connection. NOTE : This connection shall be bonded to protective earth at the source of supply in accordance with national and local electrical code requirement.

► Safety Notes

WARNING

Any interruption of the protective conductor inside or outside the apparatus, or disconnection of the protective earth terminal is likely to make the apparatus dangerous under some fault conditions. Intentional interruption is prohibited.

Note: in order to comply with the requirements of safety standard BS EN61010, the recorder shall have one of the following as a disconnecting device, fitted within easy reach of the operator, and labeled as the disconnecting device.

- a. A switch or circuit breaker which complies with the requirements of IEC947-1 and IEC947-3
 - b. A separable coupler which can be disconnected without the use of a tool
 - c. A separable plug, without a locking device, to mate with a socket outlet in the building.
1. Before any other connection is made, the protective earth terminal shall be connected to a protective conductor. The mains (supply voltage) wiring must be terminated within the connector in such a way that, should it slip in the cable clamp, the Earth wire would be the last wire to become disconnected.
 2. Before switching on the apparatus, ensure that the connected supply voltage is compatible with the apparatus. Ensure that only fuses with the required rated current and of the specified type are used for replacement. The use of makeshift fuses and the short-circuiting of fuse holders is prohibited.

3. Any adjustment, maintenance and repair of the opened apparatus under voltage, should be avoided as far as possible and, if inevitable, shall be carried out only by a skilled person who is aware of the hazard involved. When the apparatus is connected to its supply, terminals may be live, and the opening of covers or internal assemblies (except for those designed for access to be gained by hand) is likely to expose live parts. The capacitors and other components on the circuit board may temporarily retain a hazardous charge after the supply voltage has been disconnected. These capacitors and other parts must not be touched for at least 10 seconds after supply voltage disconnection.
 4. Where conductive pollution (e.g. condensation, carbon dust) is likely, adequate air conditioning / filtering / sealing etc. must be installed in the recorder enclosure.
 5. Signal and supply voltage wiring should be kept separate from one another. Where this is impractical, shielded cables should be used for the signal wiring.
 6. This apparatus has been designed and tested in accordance with applicable safety standards, and is supplied in a safe condition. This instruction manual contains some information and warnings which have to be followed by the user to ensure safe operation and to retain the apparatus in safe condition. If the equipment is used in a manner not specified by the manufacturer, the protection provided by the equipment might be impaired. Whenever it is likely that protection has been impaired, the unit shall be made inoperative, and secured against accidental operation. The manufacturer's nearest service centre should be contacted for advice.
- * A full definition of 'Hazardous' voltages appears under 'Hazardous live' in BS EN61010. Briefly, under normal operating conditions, hazardous voltages are defined as being > 30V RMS (42.2V peak) or > 60V dc.

CONTENTS

Contents.....	i
1 List of Figures.....	1-2
2 List of Tables.....	2-3
3 Introduction	3-4
3.1 Manual Layout	3-4
3.2 Recorder Description	3-4
3.3 Optional Features	3-5
3.4 Unpacking And Inspection Of Recorder	3-5
4 Installation.....	4-6
4.1 Electrical Installation	4-10
4.1.1 General Information	4-10
4.1.2 Wiring Diagram	4-12
4.2 Fitting the Chart.....	4-19
5 Operation	5-21
6 Recorder Configuration.....	6-22
7 Calibration.....	7-23
7.1 Mechanical Calibration.....	7-23
7.2 Electrical Calibration	7-24
8 Troubleshooting Guide	8-25
9 Accessories.....	9-26
9.1 Standard Accessories	9-26
9.2 Charts (Refer Table Below).....	9-27
10 Specifications*	10-28
11 Ordering Code	11-30

1 LIST OF FIGURES

Figure 1- CCR4 ASSEMBLY FRONT VIEW	3-5
Figure 2- ENVIRONMENTAL CONDITION AND OVERALL DIMENSION	4-7
Figure 3- PANEL MOUNTING AND PANEL CUTOUT	4-8
Figure 4- CLAMP MOUNTING	4-9
Figure 5- WIRING DIAGRAM	4-12
Figure 6- MAINS SUPPLY CONNECTION	4-13
Figure 7- SENSOR WIRING	4-14
Figure 8- SENSOR WIRING - RTD (Pt-100) INPUT	4-15
Figure 9- WIRING- 12V BATTERY	4-16
Figure 10- SENSOR WIRING - 4-20mA INPUT	4-17
Figure 11- RECORDER CONNECTION WITH TRANSMITTER AND EXTERNAL POWER SUPPLY:.....	4-18
Figure 12- CONNECTING RECORDER WITH TRANSMITTER AND EXTERNAL POWER SUPPLY	4-18
Figure 13- CHART MOUNTING AND CHART CLOSING POSITION	4-19
Figure 14- FRONT PANEL	5-21
Figure 15- MECHANICAL CALIBRATION	7-23
Figure 16- ELECTRICAL CALIBRATION	7-24
Figure 17- STANDARD ACCESSORIES	9-26

2 LIST OF TABLES

Table 1- MANUAL LAYOUT.....	3-4
Table 2- TROUBLESHOOTING GUIDE	8-25
Table 3- CHARTS (REFER TABLE).....	9-27
Table 4- SPECIFICATIONS FOR BLIND RECORDERS	10-28
Table 5- ACCURACY AND MEASURING RANGE TABLE FOR SENSORS	10-29
Table 6- ORDER CODE FORMAT	11-30
Table 7- CHART TABLE - CT	11-31

3 INTRODUCTION

This manual is written to familiarize the user with the installation and operation of the Smart Chart series of circular chart recorders. These recorders are capable of plotting up to 4 Individual channels using different color inks.

3.1 MANUAL LAYOUT

This manual is divided into a number of sections for quick and easy reference.

Table 1- MANUAL LAYOUT

Section 1 Introduction	Contains outline of the manual, brief description about the recorder, Optional features available and information about unpacking of the product.
Section 2 Installation	Contains details about installation of the product vis-a-vis mechanical and electrical aspects
Section 3 Operation	Contains details of the front panel display and key-board.
Section 4 Recorder Configuration	Contains details about various parameters that user can set for configuration of recorder
Section 5 Calibration	Description of the mechanical calibration procedure for the recorder.
Section 6 Troubleshooting guide	Details of most frequently encountered questions and their answers
Section 7 Accessories	Contains the list of standard accessories for the recorder along with their part nos.
Section 8 Specifications	Contains detailed specification of the recorder.
Section 9 Ordering Code	Contains details of order code to enable the user to find out the installed options by comparison with the code on recorder.

*Features and capabilities may vary depending upon the product purchased.

3.2 RECORDER DESCRIPTION

The CR 2010 series of recorders contain 1/2/3 or 4 pens, depending on number of channels, for continuous marking of circular chart recorder. Digital display is an optional feature for all models. The recorder without any display can have one channel only. **This manual pertains specifically to single pen recorder without display.**

3.3 OPTIONAL FEATURES

Following optional features are available for this series of recorders.

- Battery Back up
- Thermal (Inkless) recorder

It is possible that the recorder you received is fitted with some of the optional features. Please refer to the product code to know about installed options in your recorder.

3.4 UNPACKING AND INSPECTION OF RECORDER

G-Tek recorders are dispatched in a recyclable, environment friendly package, specially designed to give adequate protection to the recorder against likely transit damage. If the outer box shows any sign of damage, it should be opened immediately for inspection of the contents. If there is an evidence of damage, please do not operate the equipment. Contact our local representative for further information. If no apparent damage to the product is seen, Please remove all accessories and documentation from the box. Open the door of the recorder (Figure 1). Inspect the recorder for mechanical integrity. Close the door. If recorder is not to be used immediately, please re-pack it in its original packing. If the recorder is to be used immediately, please use it as per following instructions. Please preserve the original packing along with all internal material for future transport requirements.

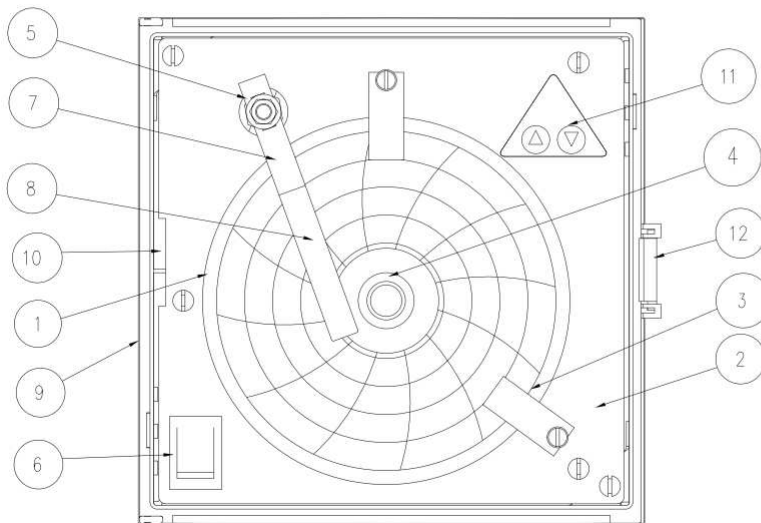

1. CHART
2. CHART PLATE
3. ACRYLIC CLAMP
4. CHART ADAPTOR
5. PEN ADAPTER
6. MAIN ON/OFF SWITCH
7. PEN ARM
8. PEN
9. MAIN BOX
10. DOOR/BEZEL
11. SWITCHES
12. LOCK CLAMP

Figure 1- CCR4 ASSEMBLY FRONT VIEW

4 INSTALLATION

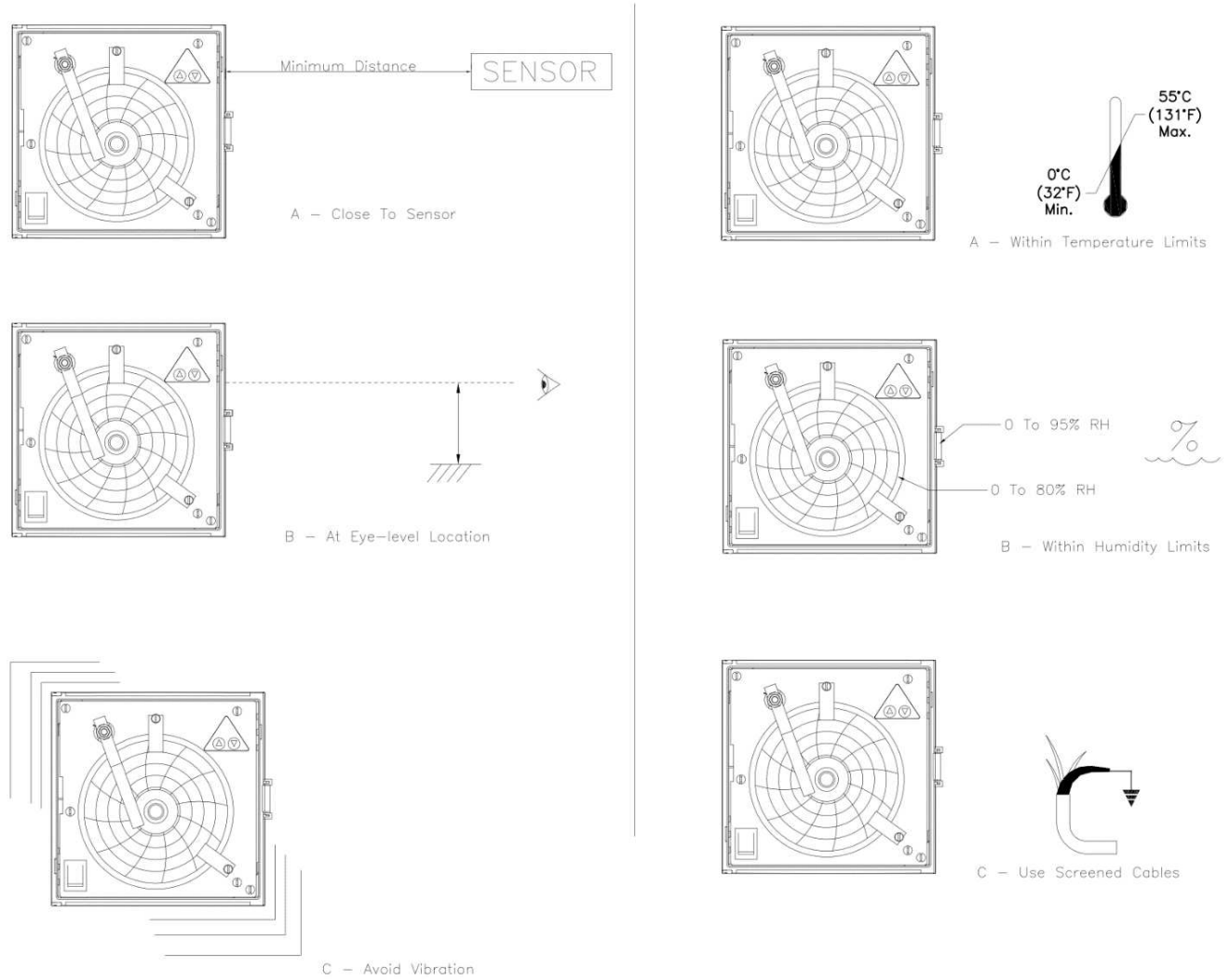

FIGURE- (2.1) ENVIRONMENTAL CONDITIONS

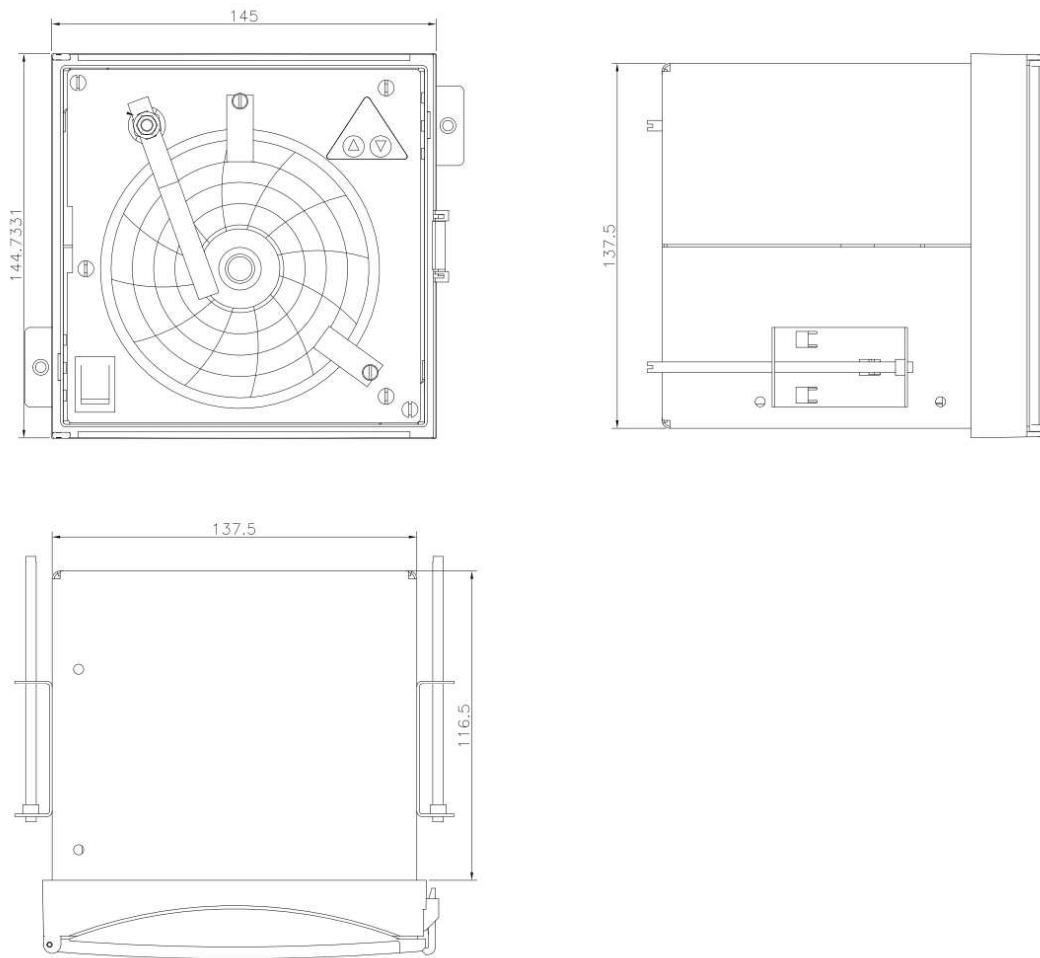
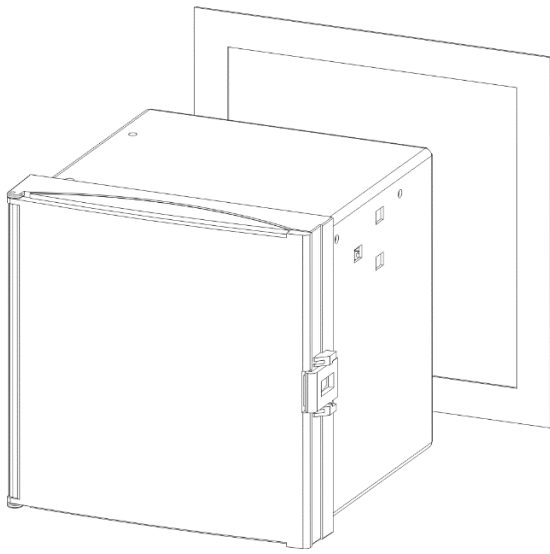
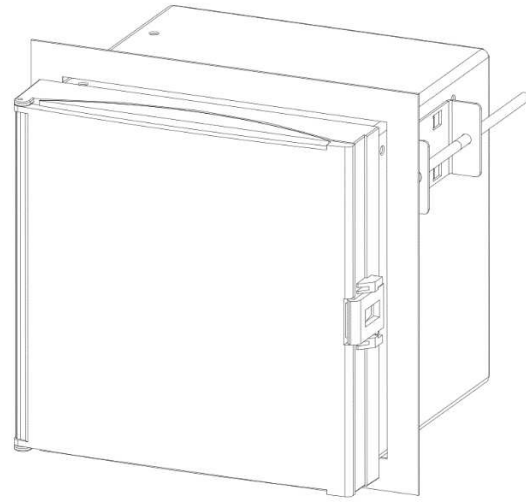

FIGURE- (2.2) OVERALL DIMENSIONS

Figure 2- ENVIRONMENTAL CONDITION AND OVERALL DIMENSION



(A) - PANEL MOUNTING



(B) - PANEL MOUNTING

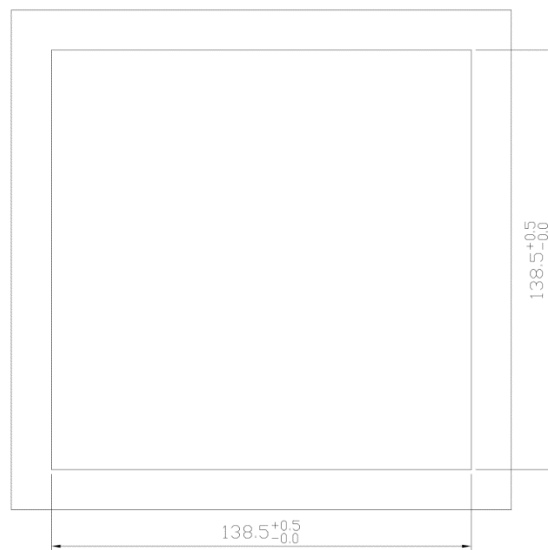

(C) - PANEL CUTOUT

Figure 3- PANEL MOUNTING AND PANEL CUTOUT

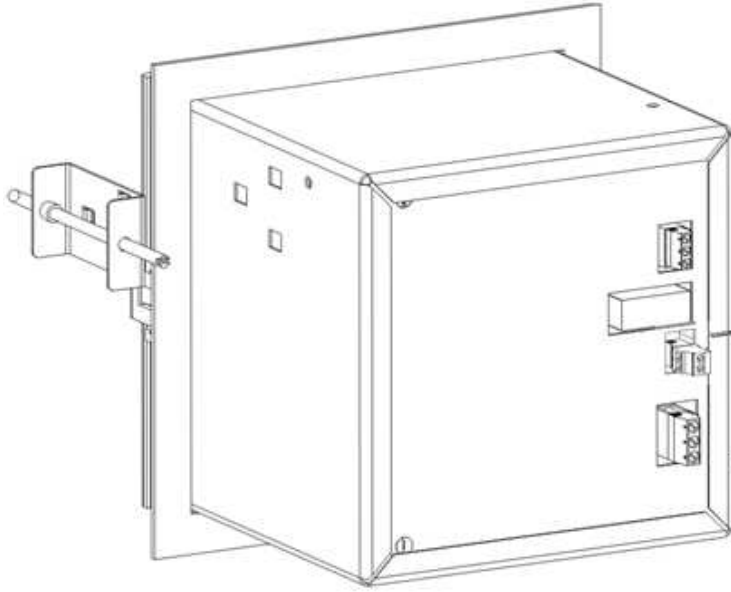

(A)

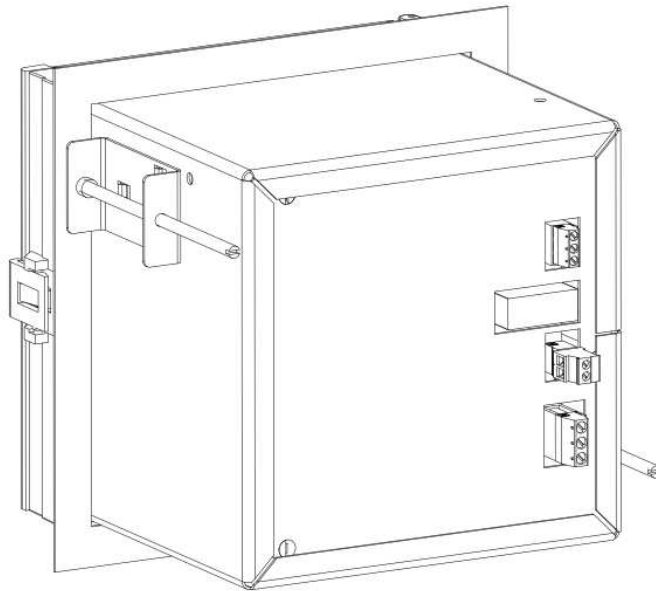

(B)

Figure 4- CLAMP MOUNTING

4.1 ELECTRICAL INSTALLATION

4.1.1 General Information



Warnings

To comply with Underwriter Laboratories (UL) and Canadian Standards Association (CSA) certification, please route signal leads and power cables in earthed (grounded), flexible metal conduit. Use the protective ground stud at the back of recorder J; (NOT the terminal module ground connection) to ground the flexible metal conduit.

- Instruments not fitted with the optional internal on/off switch and fuse should have a disconnecting device such as a switch or a circuit breaker, conforming to local safety standards, connected to it at the time of final installation. Such device must be fitted in close proximity of the instrument, within easy reach of the operator and should be marked clearly as the disconnecting device for the instrument.
- Remove all power from supply, relay, any powered control circuits and high common mode voltages before accessing or making any connections.
- Use cables which are appropriate for the load currents. The terminals accept cables up to 14AWG (2.5mm²).
- The instrument and all inputs and outputs conform to Mains Power Input Insulation Category II.
- All connections to secondary circuits should have basic insulation.
- After installation, there should be no direct access to live parts e.g. terminals.
- Terminals for external circuits are for use only with equipment with no accessible live parts.
- If the instrument is used in a manner not specified by the Company, the protection provided by the equipment may be impaired.
- All equipment connected to the instrument's terminals should comply with local safety standards (IEC 60950, EN601010-1).

NOTE:

In order to ensure optimum performance of the recorder, practice of proper installation of wiring should be followed strictly. Failure to do so can result in problems such as, but not limited to, loss of configuration to component failure, caused by transmitted or radiated electrical noise. Proper consideration must be given to local noise sources and appropriate steps taken to suppress the noise and minimize any potential problems. Among the most common sources of noise are: Relays, SCRs, valve solenoids, electric motors, power line disturbance, wire-to-wire coupling, electrostatic discharge (ESD) and radio-frequency interference (RFI).

To achieve the optimum results, please consider the following:

1. Low level signal wiring such as that associated with thermocouples, RTDs and current loops should always be kept separate from power and control output wiring.
2. Signal input wiring should be twisted pairs/triplets etc. The conductors should be stranded rather than solid in construction. All signal wiring should use ground-shielded wires, or be routed through grounded conduit to minimize the effects of RFI and ESD.
3. Special care should be taken when wiring to relay or solenoid coils, as large transients are produced when coils (or any other inductive loads like motors or arc welding equipment's etc.) are switched on. This problem can be eliminated by the use of suitable suppression devices across the coil. Coil transients can also be transmitted through the air, so the recorder itself should be mounted as far away as possible from power control devices and/or wiring.
4. When line power is poorly regulated and / or subject to voltage surges or transients, consideration should be given to the use of a line conditioning/transient suppressing line power regulator. Process control motors, valves, relays and heaters should not be connected to the same power lines that are used for instrumentation.
5. The connection of the recorder to a proper safety earth ground is essential. Such a connection not only reduces the possibility of electric shock, but also provides the required return for the recorder line power filters.
6. All local electrical codes of practice must be followed when installing any instrumentation.
7. If wall- or pipe-mounting to NEMA 4X (IP65) hose down standard is required, suitable cable glands must be used to prevent water ingress.

4.1.2 Wiring Diagram

All the connections are made at the back panel. All the connectors are removable plugs. The mains connector is bigger than the Sensor Connectors. The Mains & Sensor Connectors are shown in Figure 5.

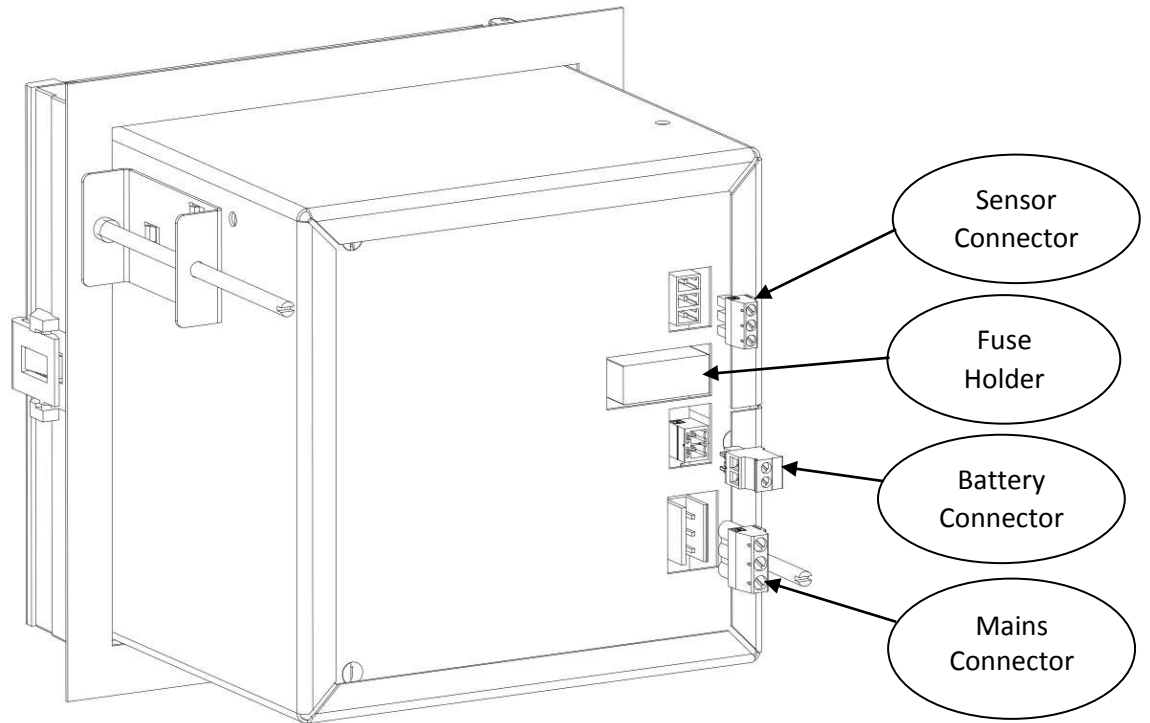

Figure 5- WIRING DIAGRAM

4.1.2.1 Mains Supply Connection

The connection for Mains supply is shown in figure 6. As per the figure, the live, neutral & earth from the mains cord are connected to terminals marked L, N & E respectively. Ensure that the exposed ends of the mains connector are not exposed and that there is no loose/improper connection.

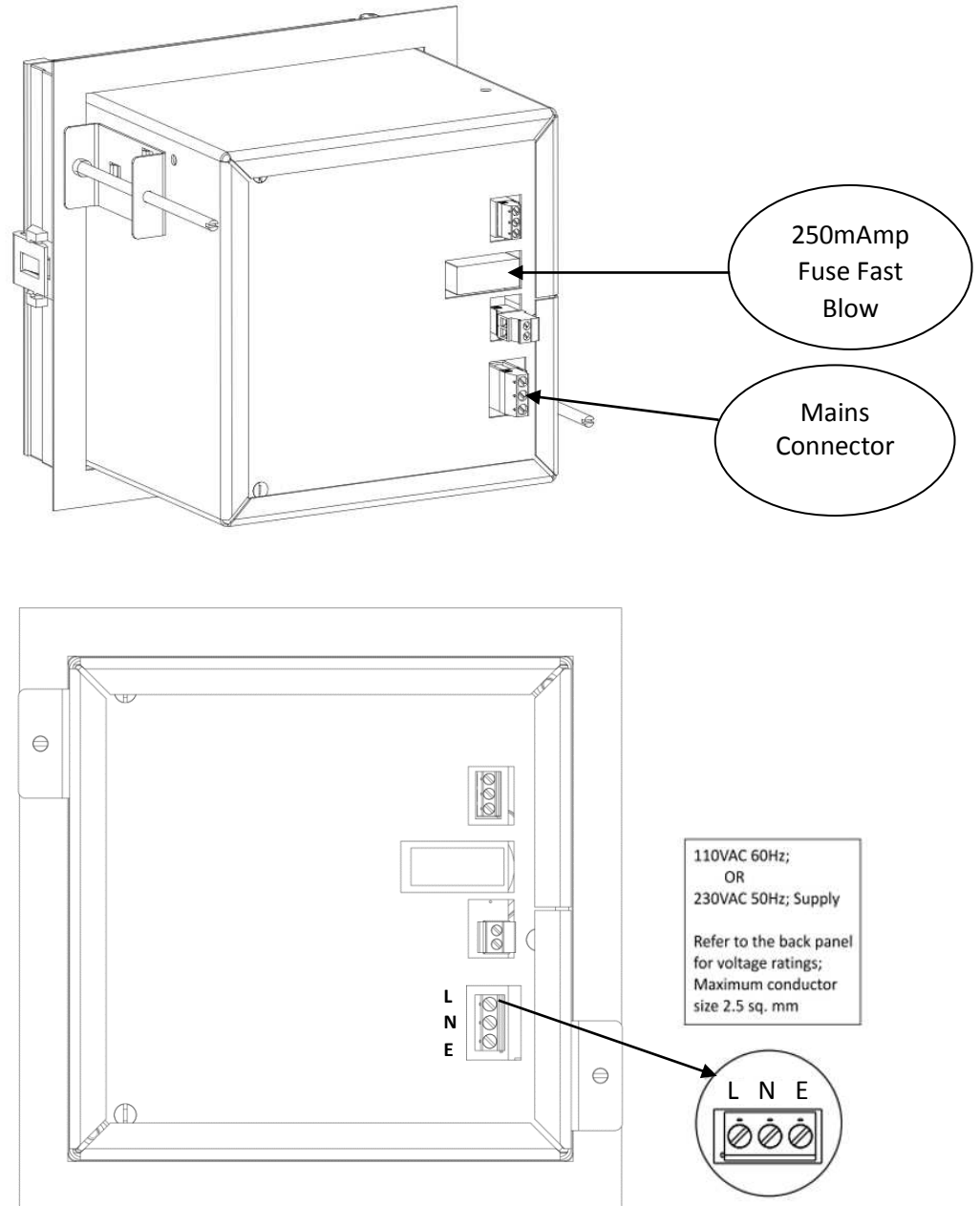

Figure 6- MAINS SUPPLY CONNECTION

4.1.2.2 Wiring of Sensor

Please refer to the back panel of recorder to know the type of sensor input. Sensor inputs are not configurable at site, by the user.

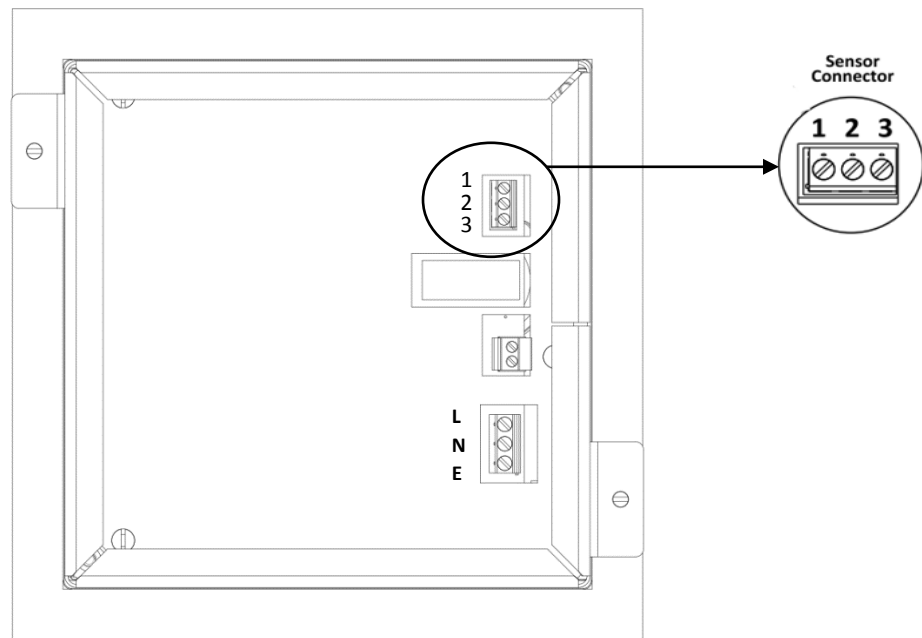
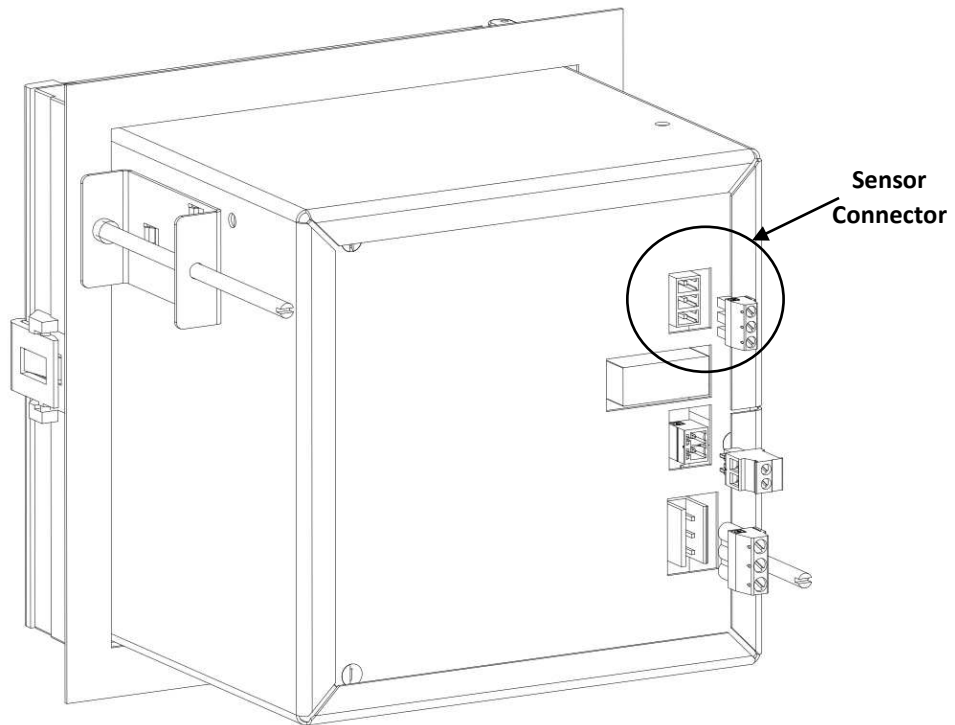

Figure 7- SENSOR WIRING

4.1.2.3 Wiring of Sensor - RTD (Pt-100) Input

The Connection for 3-wire and 2-wire RTD sensor is shown in figure 8. Normally, RTD Sensor with 3 wires has two wires of same color and the third one of different color. Connect two wires with same color at 2 and 3. Connect the remaining different colored wire at 1.

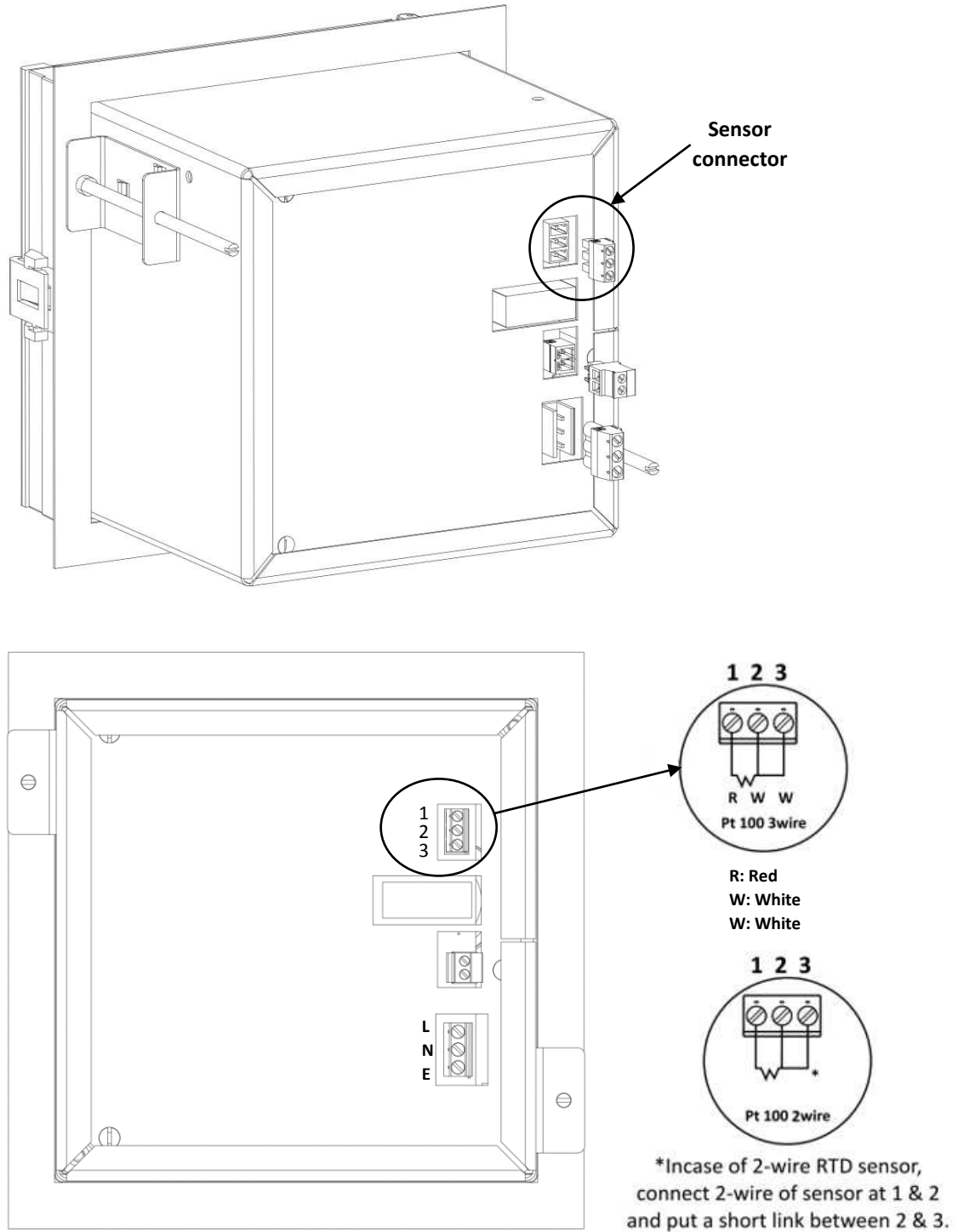

Figure 8- SENSOR WIRING - RTD (Pt-100) INPUT

4.1.2.4 Wiring of 12V Battery

Wiring for 12V Battery is shown in figure 9.

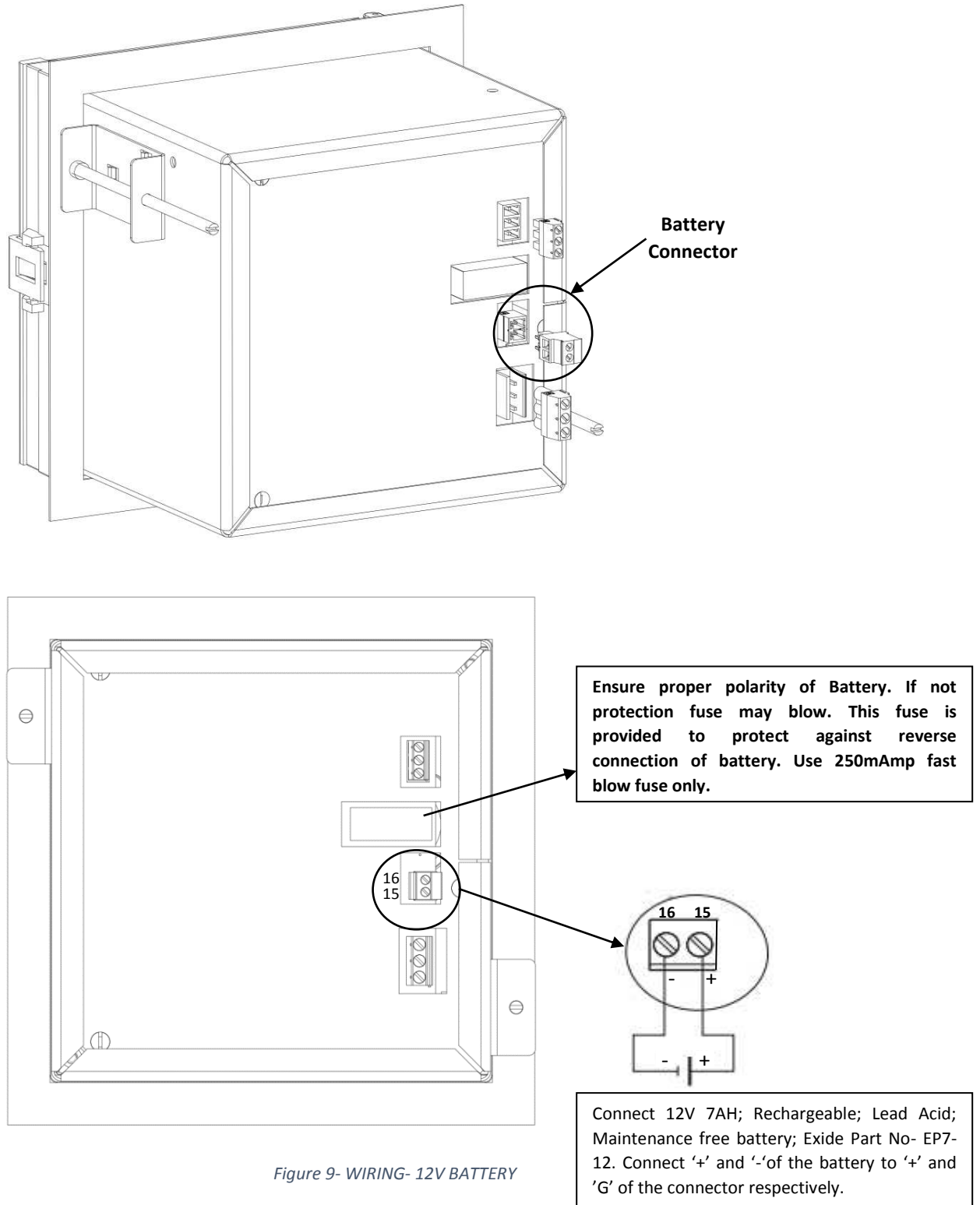

Figure 9- WIRING- 12V BATTERY

4.1.2.5 Wiring of Sensor - 4-20mA Input

The sensor wiring of 4-20mA input is shown in Figure - 10.

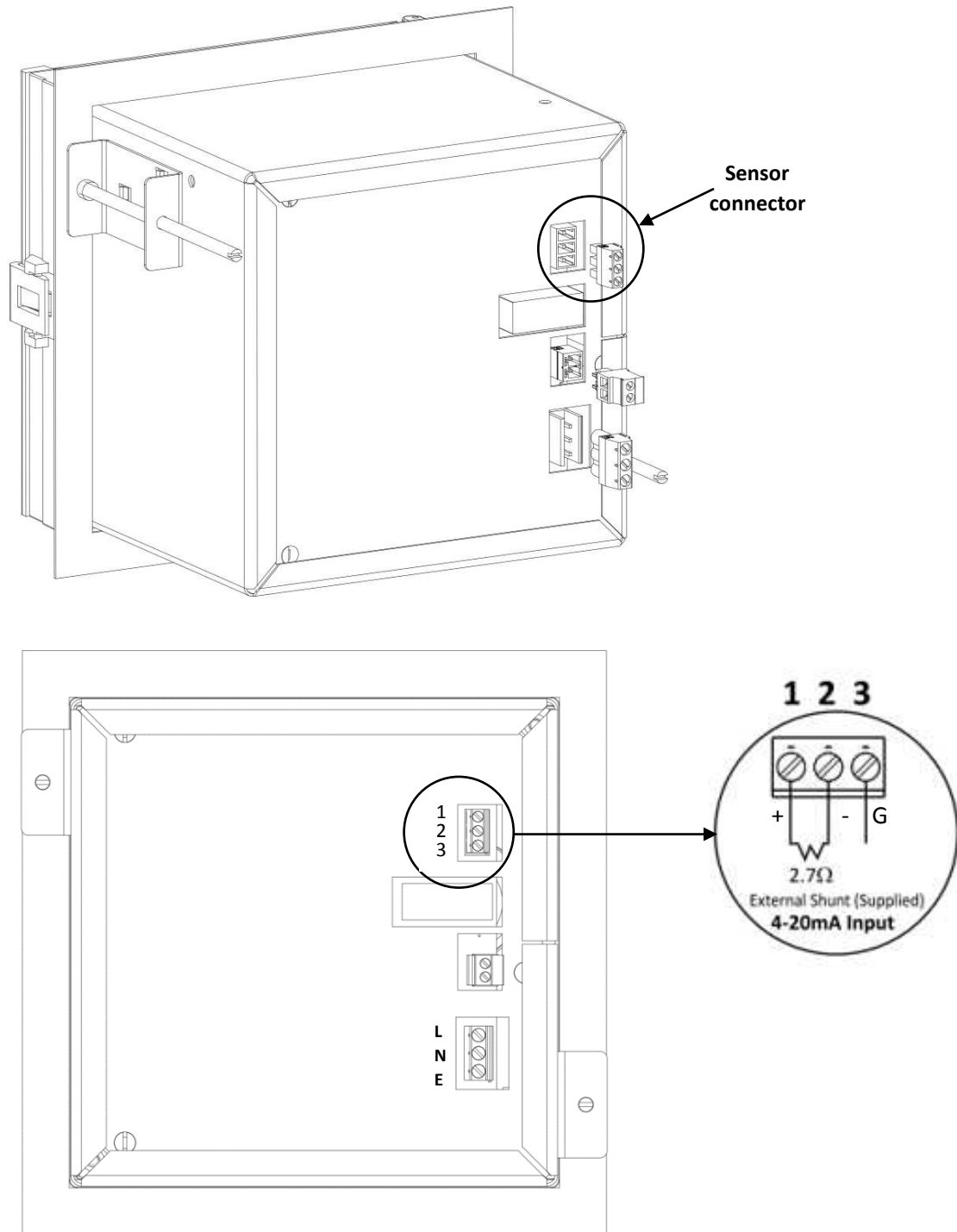
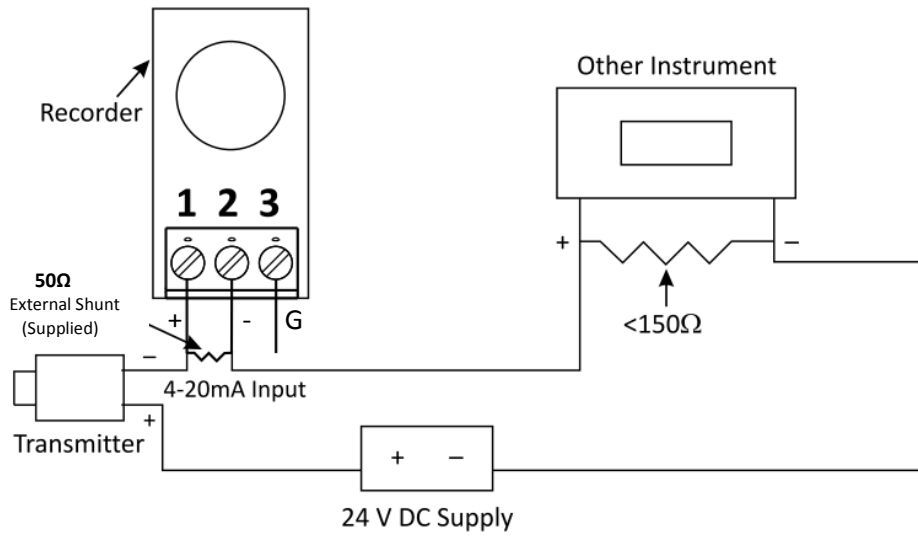

Figure 10- SENSOR WIRING - 4-20mA INPUT

Connecting Recorder and Other Instrument in Series with Transmitter and External Power Supply:



* If required, put link between 2 & 3.

Figure 11- RECORDER CONNECTION WITH TRANSMITTER AND EXTERNAL POWER SUPPLY:

Connecting Recorder with Transmitter and External Power Supply:

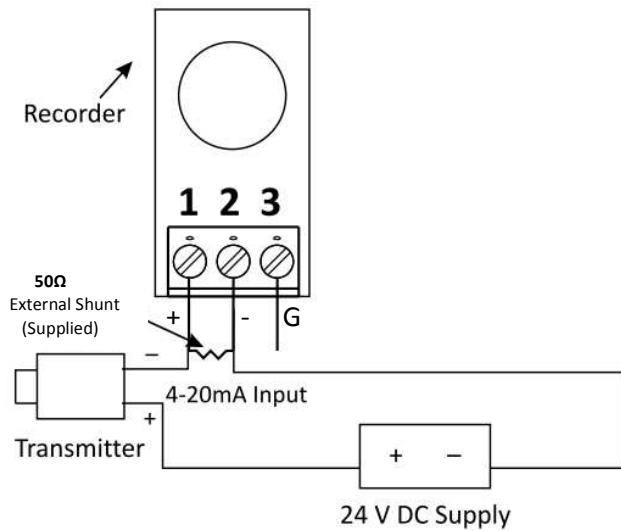

* If required, put link between 2 & 3.

Figure 12- CONNECTING RECORDER WITH TRANSMITTER AND EXTERNAL POWER SUPPLY

Caution:

A transmitter in a current loop must not be shorted. If it is, the transmitter power supply is essentially connected directly across the input shunt. In such case, the shunt will almost certainly suffer damage.

4.2 FITTING THE CHART

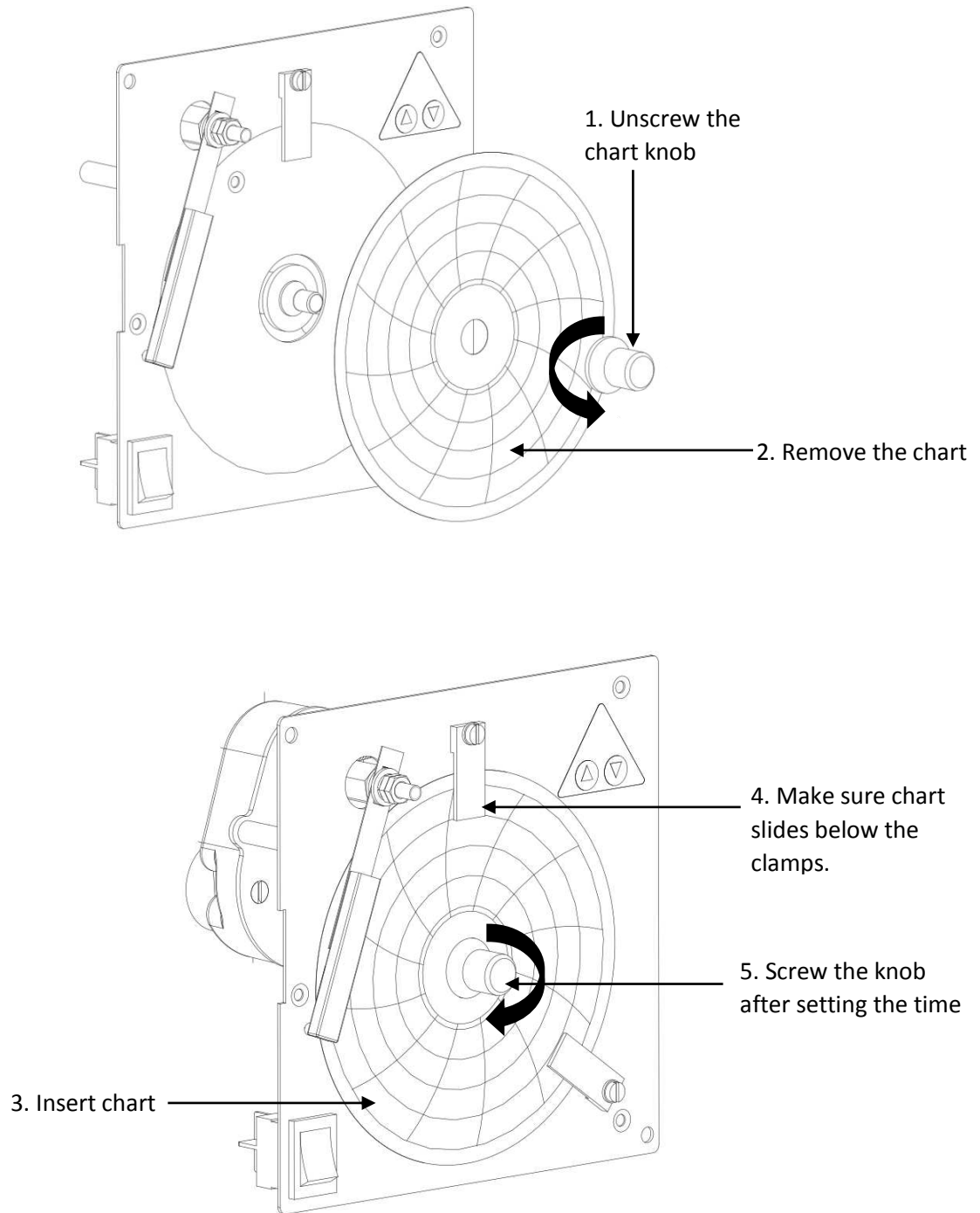

Figure 13- CHART MOUNTING AND CHART CLOSING POSITION

To replace the chart, please carry out the following procedure:

- Open the door of the recorder.
- Unscrew the chart knob as shown in the figure.
- Lift the pen arm gently. Ensuring that it does not lose its form.
- Remove the chart.
- Insert the new chart.
- Screw the knob after setting time axis. Make sure that chart slides below the clamp as shown in the figure.
- Ensure that pen touches the graph paper. If it does not, press gently near the pen adapter so that the pen touches the paper. **Pressing it too much may result in pen bloating on paper.**

5 OPERATION

After ensuring that the wiring is proper and the pen and chart are fitted correctly, power on the recorder. The pen will move towards the center of the chart. After reaching the center of the chart, it will stop. After a while pen will move to the position on the chart as per the parameter value. The center of the chart is designated as range low of the recording. Whenever the measured value is less than the range low of the recorder, pen moves till zero and stops there. The full range of the chart is computed as follows.

Full range (100% of the chart) Value = Range low of the chart + Span of the chart.

e.g.: for the chart with the marking of -10 to + 40 with +40 marked at the center of the chart,

Range Low = +40

Span = -50

Full range = 40 -50 = -10

For the recorder in example, when the parameter value is equal or less than -10, the pen will remain at full scale of the chart. When the parameter values is equal or more than +40, pen will remain at center of the chart.

Front Panel

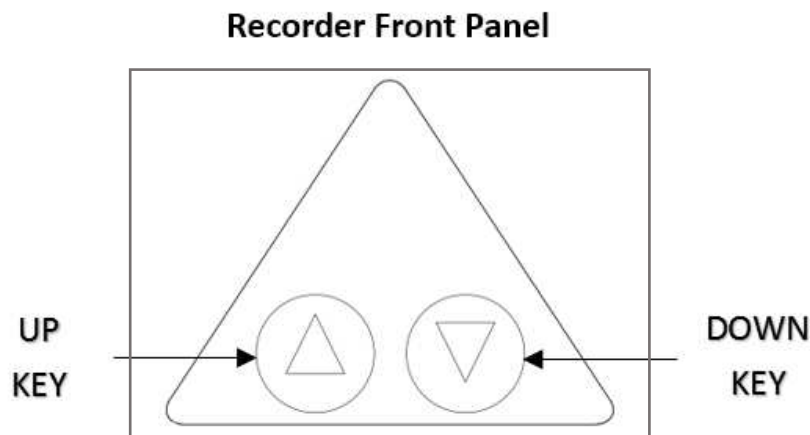

Figure 14- FRONT PANEL

For the recorders having no display, two keys \triangle and ∇ are used to set various parameters like offset in the measurement and mechanical calibration. The operator menu is entered using the two keys given on the front side. In this recorder, changing of Range low, Span and type of Sensor is not possible. The recorder without display has only two keys and the various calibration parameters are set using these keys. The \triangle key is used to move the pen away from the center of the chart whereas ∇ key is used to move the pen towards the center of the chart.

6 RECORDER CONFIGURATION

There are no configuration parameters settable except mechanical and electrical calibrations.

7 CALIBRATION

7.1 MECHANICAL CALIBRATION

This involves setting of pen at zero and pen at full scale on the chart, through the front panel key board. User can calibrate the Recorder by following the sequence as shown in Figure 15.

MECHANICAL CALIBRATION*

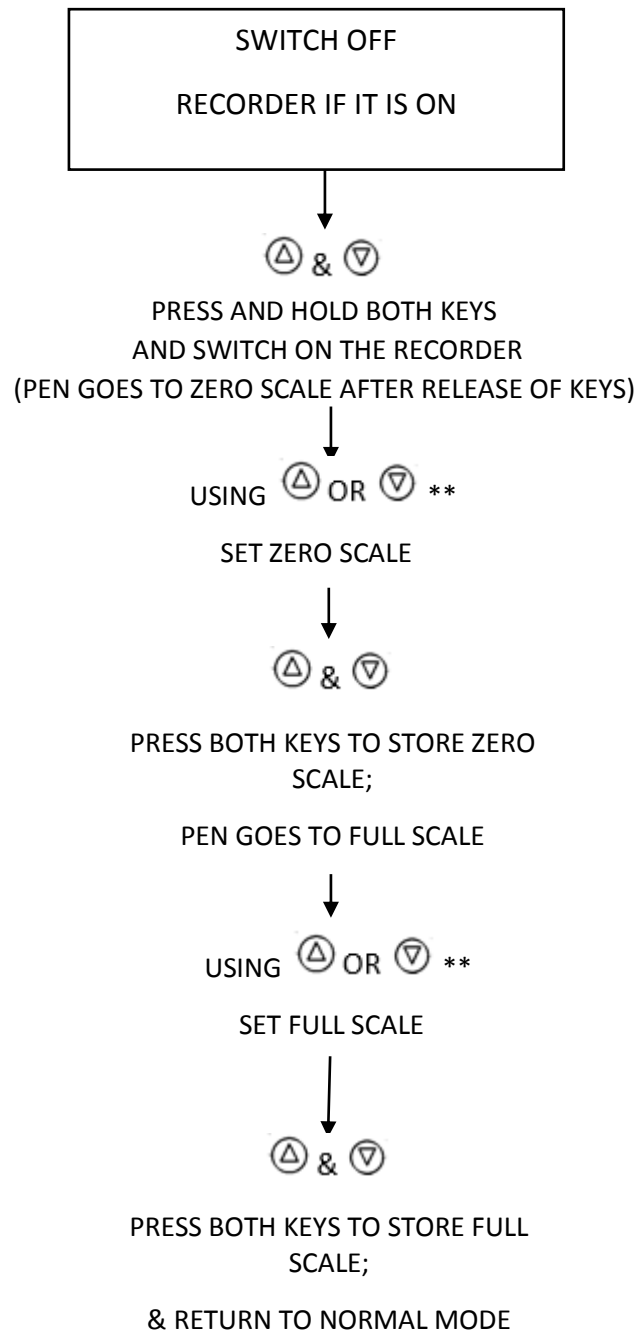

Figure 15- MECHANICAL CALIBRATION

Note:

* If the error is large, you may need to carry out the same exercise twice or thrice to set the value properly.

** ⬆ Pen moves away from the center of chart.

⬇ Pen moves towards the center of chart.

7.2 ELECTRICAL CALIBRATION

This involves aligning the pen to the known parameter value on chart, through the front panel key board. User can calibrate the Recorder by following the sequence as shown in Figure 16.

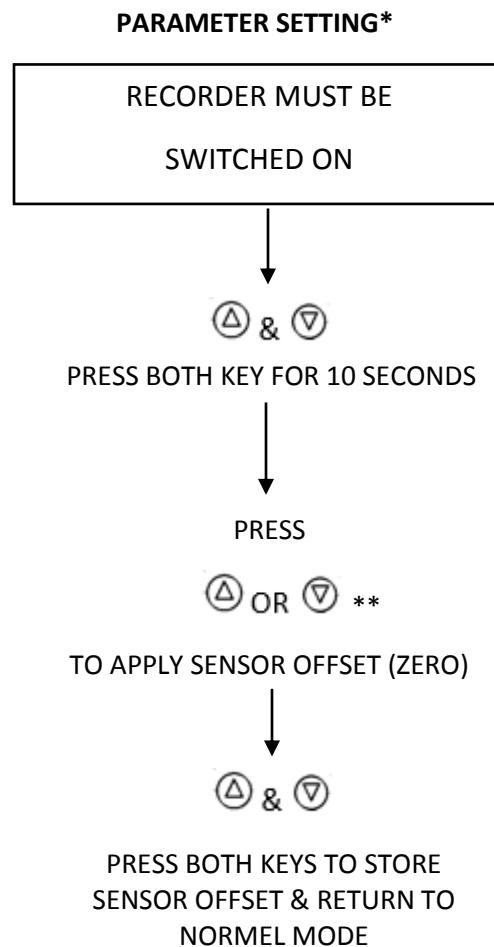

Figure 16- ELECTRICAL CALIBRATION

Note:

* If the error is large, you may need to carry out same exercise twice or thrice to set the value properly.

** ⬆ Pen moves away from the center of chart.

⬇ Pen moves towards the center of chart.

8 TROUBLESHOOTING GUIDE

Table 2- TROUBLESHOOTING GUIDE

Problem	Corrective Action
Power is On but the pen does not move.	<ul style="list-style-type: none"> • Pen motor is faulty — Replace it • If the problem still persists, contact G-Tek
Chart reading is different than other known or measured readings	<ul style="list-style-type: none"> • Follow the procedure of electrical calibration and correct the error if any.
Reading is not stable	<ul style="list-style-type: none"> • Replace the sensor with fixed known input. If the problem is solved, check and replace the sensor • If problem persists, contact G-Tek
Pen does not respond to input	<ul style="list-style-type: none"> • Check for the range of the recorder and ensure that the inputs are within the range. • If the inputs are within range, carry out the mechanical calibration. • If problem persists, contact G-Tek
Pen movement is jerky	<ul style="list-style-type: none"> • Contact G-Tek
Calibration settings cannot be performed	<ul style="list-style-type: none"> • Contact G-Tek

9 ACCESSORIES

9.1 STANDARD ACCESSORIES

1. Charts Pack of 30

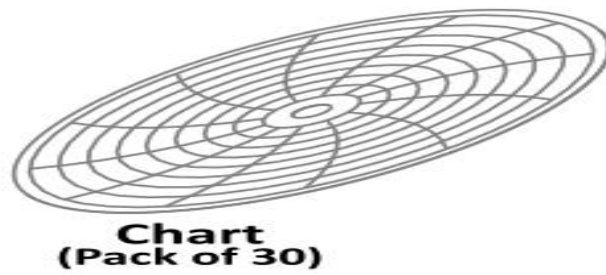

2. Panel Mounting Clamps: 2 numbers; Part No. - 210034

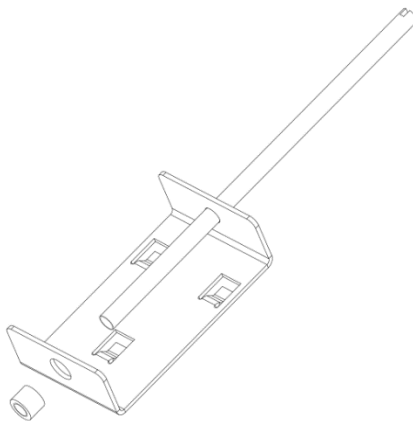

Panel Mounting Clamps

Figure 17- STANDARD ACCESSORIES

3. Pen: 5 Nos. (Red Pen); Part No. – 217006

Pen

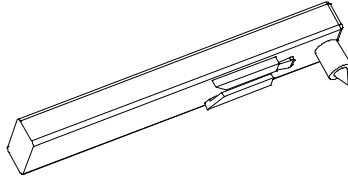

9.2 CHARTS (REFER TABLE BELOW)

Table 3- CHARTS (REFER TABLE)

Sr. No.	Range*	Speed	Size	Part No.	Part Description
1	-10 to +32	7D	4"	303006	W4-1032
2	+32 to -10	7D	4"	303001	W432-10
3	+34 to -50	7D	4"	303002	W434-50
4	-50 to +34	7D	4"	303004	W4-50+34
5	-6 to -90	7D	4"	303003	W4-6-90
6	-8 to -50	7D	4"	303005	W4-8-50
7	-10 to +32	7D	4"	303008	W432-10 PS [#]
8	+32 to -10	7D	4"	303007	W4-10+32 PS [#]
9	-40 to -124	7D	4"	303009	W4-40-124
20	Other				

*The first no in the range column is in center of chart for example for the chart range of -10 to +34; center of the chart will be marked with -10 and outermost circle of the chart will be marked with +34.

Pressure Sensitive Chart

10 SPECIFICATIONS

The Full Specification for Blind Recorders is given in the below table

Table 4- SPECIFICATIONS FOR RECORDERS WITHOUT DISPLAY

Model No	CR2010 Series; 4" recorder
Product Code*	1xx00
Recording System	
Pens	
No. of Pens	1
Pen Marking	Continuous
Pen Response Time	<5Sec (Full Scale)
Pen Resolution	Stepper Motor Controlled better than 0.1% FSD
Overshoot	None
Chart	
Chart Speed	4H/Rev, 24H/Rev, 168H /Rev
User setting	Fixed
Chart Calibrated Radius	1.3" (approx. 34mm)
Chart Ranges	Standard / Customized
Chart Size	Circular 4" (approx.)
Overshoot	None
Display and Operator Panels	
Display Type	None
Display Height	None
Status Indicator	LED
Panel Keys	Front panel KB consisting of 2 keys for programming and calibration
Analog Input	RTD PT-100 / 0-1V/4-20mA/0-20mA (External Shunt Resistance of 50Ω)
Sensor Type and Range	Refer Table 5
Scan Rate	Continuous 1reading per second
Protection	
Input Impedance RTD / Volt	> 20 MΩ
Input Impedance mA	50/ 2.7Ω Shunt External
CMRR	>100 dB@ 50, 60 Hz at 3 Sample per Second
NMRR	>50 dB@ 50, 60 Hz at 3 Samples per Second
Maximum Common Mode Voltage	5V AC
Isolation Channel – EARTH	NA

Input Protection	30V AC/DC Max
┐	
Environmental	
Temperature	(Operation) 5°C to 45°C
	(Limiting) 0°C to 50°C
	(Storage) -20°C to 60°C
Humidity	(Operation) 10 to 80 % RH Non Condensing
	(Storage) 5 to 90 % RH Non Condensing
Altitude	<2000 meter
Power Requirement	
Supply Voltage (Mains Operated)	85-264VAC 47-63Hz
Battery backup	Yes
DC Adapter Operated	Yes
Power	15W Max With Maximum Configuration
Fuse Type	None
Battery Backup	
Battery	12V 7Ah External Lead Acid battery
Battery Charger	Yes
Battery Reverse Polarity	Protected
Minimum Back up	24 Hrs.
Safety	
Safety	IEC 61010-1
EMI-EMC	EN 61326 Class A
Pollution Degree	II
Installation Category	III
Vibration	2g Peak (10Hz to 150Hz)
Shock	IEC 61010-1
IP Rating	IP30 (Door and Bezel only)
Overall Dimension	
Dimension L x W x D (mm)	144x144x150
Panel Cutout (mm) (L x W)	138x138
Bezel (mm)	144x144

Table 5- ACCURACY AND MEASURING RANGE TABLE FOR SENSORS

Input Type	Valid Input Range	Resolution Chart	Accuracy	Linearization Error
Pt-100 (RTD)	-200 to +850 ° C	2%	± 0.5% FSD	±0.7°C Max
mA	4-20 mA	2%	± 0.5% FSD	± 0.1% Max

*Exact Specifications may vary depending on the product you have purchased.

11 ORDERING CODE

Order Code for CCR4

Table 6- ORDER CODE FORMAT

Recorder type		P= Pen , PS= Pressure Sensitive ,		Power Supply		Relay		PC Interface	
CR		PD		PS		RE		PI	
1	CR4-NU	0	1P ND	0	85-264 V AC; 47-63 Hz	0	None	0	None
		5	1PS ND	4	85-264 V AC; 47-63 Hz; BB				

BB – Battery Backup

CT - Chart Type (Table 7)		R=Range		CS=Chart Speed		S=Sensor Type	
x	x	R		CS		S	
		1	Fixed	4	7 Day/Rev	1	RTD
				9	Other Please Specify	2	4-20mA

Table 7- CHART TABLE - CT

xx	Description			Store ID	INSIDE	OUTSIDE	*
01	Chart	W	4	303006	-10	+32	
02	Chart	W	4	303001	+32	-10	
03	Chart	W	4	303002	+34	-50	
04	Chart	W	4	303004	-50	+34	
05	Chart	W	4	303003	-6	-90	
06	Chart	W	4	303005	-8	-50	
07	Chart	W	4	303008	-10	+32	PS
08	Chart	W	4	303007	+32	-10	PS
09	Chart	W	4	303009	-40	-124	
20	Other						

NOTE: - *

T	Thermal Chart
PS	Pressure Sensitive Chart
W	Weekly Chart
D	Daily Chart
4H	4 Hour Chart
DR	Dual Range Chart