

# OPERATING MANUAL

## **Pro** **CR-2010**

### CR-2010 Pro Series 6" Circular Chart Recorder Model No.: 20xxx / 25xxx



Manufacturers of :

- Circular Chart Recorders
- Inkless Recorders
- Paperless Recorders
- Scanners & Data Loggers
- Networked Data Loggers
- Application Software
- WHO PQS Qualified Data Loggers
- Vaccine Series Data Loggers

**G-TEK CORPORATION PVT. LTD.**

"Gunaji House"  
Plot No. 25/1, Besides Status Bungalow,  
Padra Road, Vadodara – 391410.  
tel.: +91-98245 24140  
e-mail: [info@gtek-india.com](mailto:info@gtek-india.com)  
url: [www.gtek-india.com](http://www.gtek-india.com)

# CONTENTS

---

Contents.....	0
1 List of Figures .....	1
2 List of Tables .....	1
3 Safety and The Environment.....	2
3.1 About This Document .....	2
3.2 Ensure Safety .....	2
3.3 Protecting The Environment.....	2
4 Specifications .....	3
4.1 Use of The Recorder.....	3
4.2 Technical Specifications .....	3
5 Unpacking The Product.....	6
5.1 Unpacking and Inspection of The Recorder.....	6
5.2 Installation of The Recorder.....	8
5.3 Overall Mechanical Dimensions.....	9
6 Electrical Installation.....	11
6.1 Wiring Diagram for Recorder.....	11
6.2 Fitting the Pen.....	12
6.3 Fitting the Chart .....	13
7 Operation .....	14
7.1 Front Panel.....	14
7.2 Mechanical Calibration .....	15
7.3 Electrical Calibration .....	16
8 Frequently Asked Questions(FAQs) .....	17
9 Standard Accessories .....	18
10 Order Code.....	19

# 1 LIST OF FIGURES

---

Figure 1 – Front and Back View of The Chart Recorder .....	7
Figure 2 - Environmental Conditions .....	8
Figure 3 - Overall Mechanical Dimensions.....	9
Figure 4 - Panel Mounting.....	10
Figure 5 – Back panel view.....	11
Figure 6 - Fitting / Replacing the Pen.....	12
Figure 7 - Chart Fitting .....	13
Figure 8 – Front panel of Chart Recorder without display.....	14
Figure 9 – Mechanical Calibration Menu .....	15
Figure 10 – Electrical Calibration Menu .....	16
Figure 11 – Accessories .....	18

# 2 LIST OF TABLES

---

Table 1 Specifications.....	3
Table 2 Chart type of Chart Recorder .....	4
Table 3 Connection Notations .....	11
Table 4 Frequently Asked Questions (FAQs).....	17
Table 5 Order code.....	19

## 3 SAFETY AND THE ENVIRONMENT

---

### 3.1 ABOUT THIS DOCUMENT

- This instruction manual is an essential component of the product.
- Please read this documentation carefully and pay attention to the safety instructions and warning notices to prevent injuries and damage to the product.
- This manual is written specific for one pen recorder with display.
- Keep this document handy so that you can refer to it when necessary.

### 3.2 ENSURE SAFETY

- Operate the product properly, for its intended purpose and within the parameter specified in the technical data. Using it beyond the specified limit can cause the damage to the product and personnel also.
- Do not use the product if there are signs of damage to the housing.
- Carry out only the maintenance and repair work on this instrument that is described in the documentation. Follow the prescribed steps exactly. Use only original spare parts from Gtek.

### 3.3 PROTECTING THE ENVIRONMENT

- Dispose of faulty rechargeable batteries/spent batteries in accordance with the valid legal specifications.
- At the end of its useful life, send the product to the separate collection for electric and electronics devices (observe local regulations) or return the product to Gtek for disposal.
- Dispose or recycle the recorder in accordance with the WEEE 2012/19/EU guidelines or your local regulations. For the suitable recycling, the device may also be returned to the manufacturer.

## 4 SPECIFICATIONS

---

### 4.1 USE OF THE RECORDER

The CR-2010 Pro Series of the recorder comes as either 1 or 2 pen continuous marking circular chart recorder. The Recorder with no display can have single channel only. This manual is written specifically for single pen recorder without display.

This chart recorder has 2 multipurpose keys which enables user to easy programming/configure the unit.

### 4.2 TECHNICAL SPECIFICATIONS

Table 1 Specifications

Model No	CR-2010 Pro
No. of Pens	1
Pen Response Time	< 5 Sec. (Full Scale)
Pen marking	Continuous
Display Type	NA
Power LED Color	Red
Panel Keys	Front panel KB consisting of 2 keys for programming and configuration setting
Status Indicator	LED
Analog Input*	RTD (Pt-100)/ 4-20mA (External Shunt Resistance of 50Ω 0.1%)
Supply Voltage**	85-264 VAC 47-63Hz
Power	15 W Max with Maximum Configuration
Fuse Type	None
Battery backup	Yes
Battery	12V 7Ah External Lead Acid battery
Battery Charger	Yes (In built)
Battery Reverse Polarity	Protected
Minimum Back up	72 Hours
Termination	Non-Interchangeable, Removable Plugs, Individual for Each Input
Max No of Analog Input Per Device	1
Data Storage	None
Password	None

Mounting	Panel Mount
Chart speed	4 hour/ 24 hour/ 7 day per revolution
Chart Calibrated Radius	2.3" (approx. 59mm)
Chart Size (diameter) approx..	Circular, 6" (calibrated radius 75mm)
Chart Ranges	Refer Table 1
Temperature	(Operation) 5°C to 45°C (Limiting) 0°C to 50°C (Storage)-20°C to 60°C
Humidity	(Operation) 10 to 80 % RH Non-Condensing (Storage) 5 to 90 % RH Non-Condensing
Altitude	<2000 meter
Safety/EMI-EMC	IEC 61326-1 Class A
Pollution Degree	II
Installation Category	III
Vibration	2g Peak (10Hz-150Hz)
Shock	IEC 61010-1
IP Rating	IP50 (Door and Bezel Only)

\*Actual specifications may vary depending on the optional features installed.

\*\*Refer to the back panel of recorder for exact rating.

Table 2 Chart type of Chart Recorder

Sr. No.	Range**	Speed	Size	Part No.	Part Description
21	0 to +100	24H	6"	304001	D60100
22	0 to +150	24H	6"	304002	D60150
23	0 to +200	24H	6"	304005	D60200
24	0 to +300	24H	6"	304008	D60300
25	-50 to +50	24H	6"	304016	D6-50+50
26	0 to +160 & -1 to 3	24H	6"	304004	D60160&-1+3
27	+90 to +140	4H	6"	305001	4H90140
28	0 to +100	7 Day	6"	307001	W60100
29	-50 to +50	7 Day	6"	307010	W6-50+50
30	+50 to -50	7 Day	6"	307009	W650-50
31	-100 to +50	7 Day	6"	307005	W6-100+50
32	+50 to -100	7 Day	6"	307008	W650-100
33	+40 to -10	7 Day	6"	307007	W640-10
34	0 to +50	7 Day	6"	307004	W6050
35	0 to +10	7 Day	6"	307012	W6010

36	+20 to -10	7 Day	6"	308009	W620-10PS
37	+50 to -100	7 Day	6"	308004	W650-100PS
39	+40 to -10	7 Day	6"	308003	W640-10PS
40	-50 to +50	7 Day	6"	210042	W6-5050PS
	Other Please Specify				

\*\* The center of the chart is designated as range low value of recording.

## 5 UNPACKING THE PRODUCT

### 5.1 UNPACKING AND INSPECTION OF THE RECORDER

G-Tek recorders are dispatched in a recyclable, environment friendly package, specially designed to give adequate protection to the recorder against transit damage. If the outer box shows any sign of damage, it should be opened immediately for inspection of the contents. If there is evidence of damage, please do not operate the equipment. Contact our local representative for further information. If no apparent damage to the product is seen, please remove all accessories and documentation from the box. Open the door of the recorder (Figure 1). Inspect the recorder for mechanical integrity. Close the door. If recorder is not to be used immediately, please re-pack it in its original packing. If the recorder is to be used immediately, please use it as per following instructions. Please preserve the original packing along with all internal material for future transport requirements.

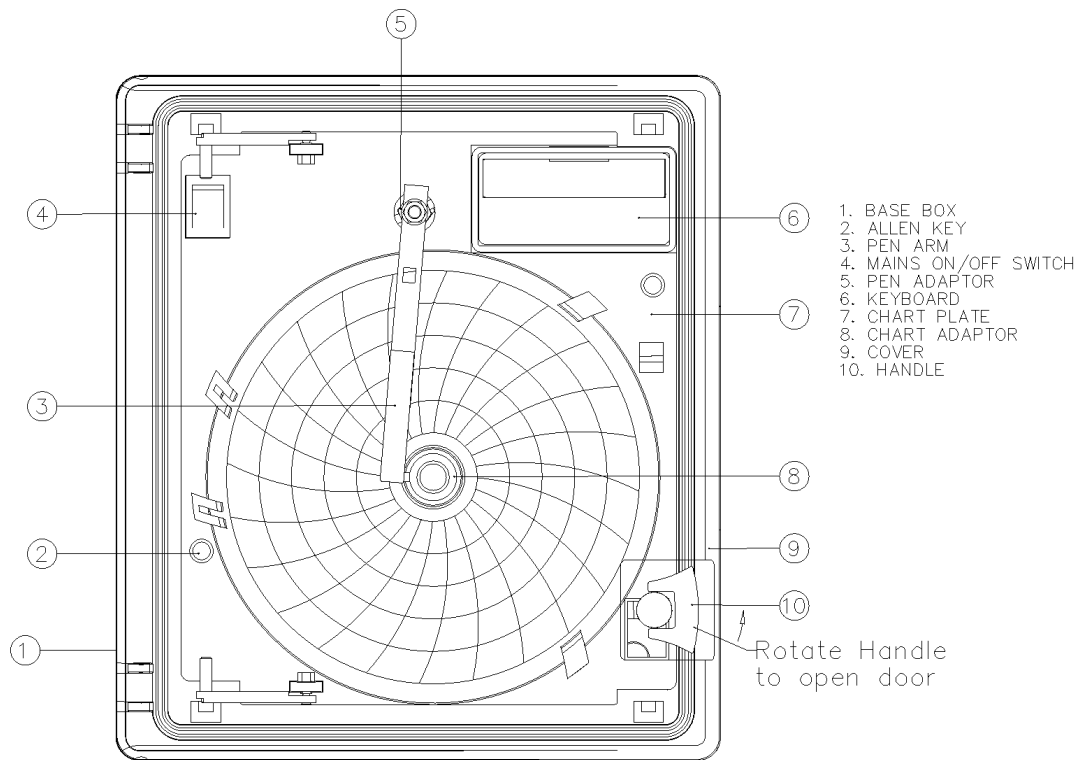

Figure 1(A) Front View of recorder

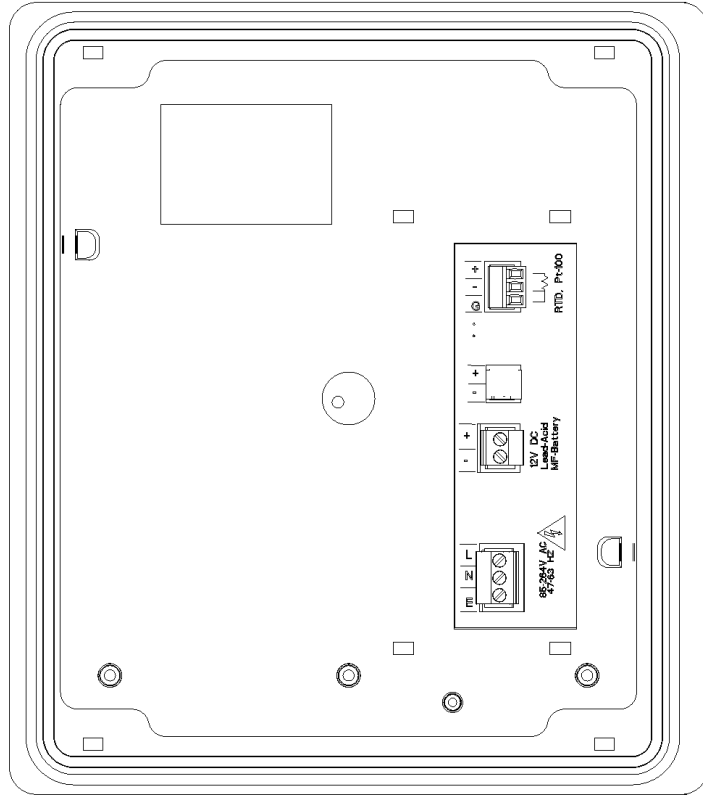

Figure 1(B) Back view of recorder

Figure 1 – Front and Back View of The Chart Recorder

## 5.2 INSTALLATION OF THE RECORDER

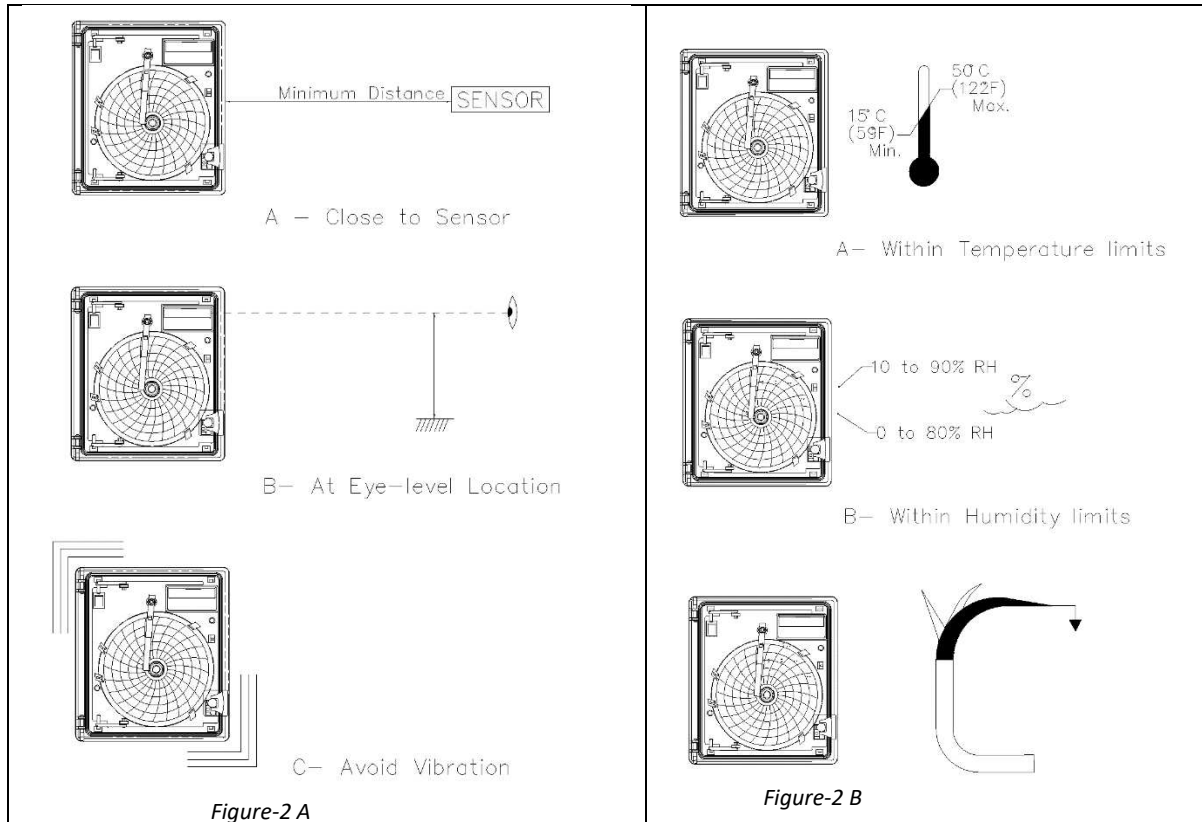

Figure 2 - Environmental Conditions

### Environmental Conditions:

Recorder should be used with proper environmental conditions for better operation. The environmental conditions are shown in Figure 2.

## Attention

Select a location away from strong electrical and magnetic field. If this is not possible, particularly in application where mobile communication device is expected to be used, screened cables within earthed (grounded) metal contact must be used as shown in above figure 2B.

### 5.3 OVERALL MECHANICAL DIMENSIONS

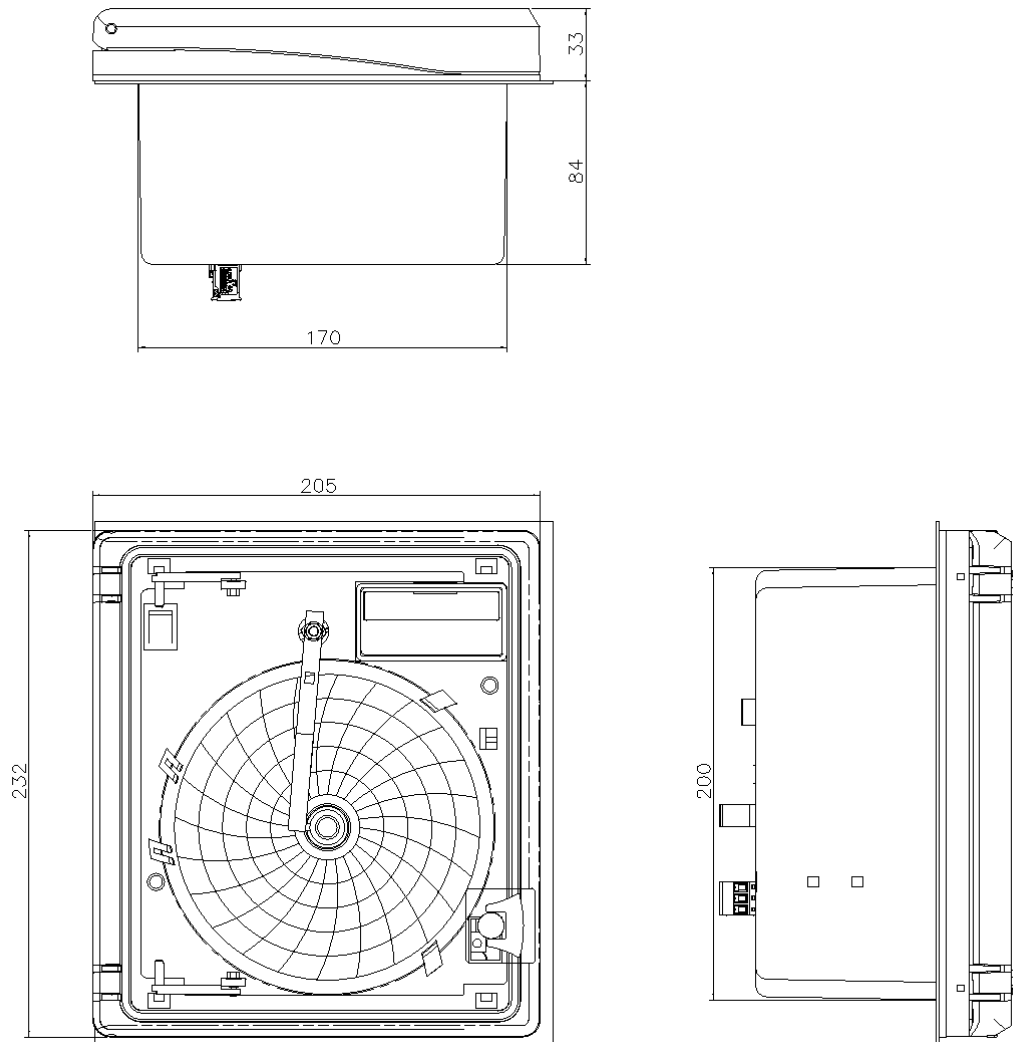
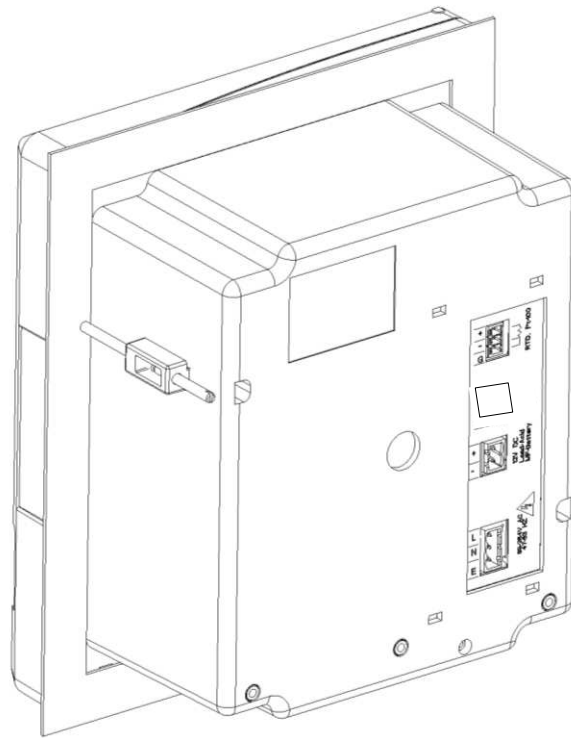

Figure 3 - Overall Mechanical Dimensions

<b>Overall Dimensions( approx.)</b>	
Dimensions L x W x D (mm)	232 x 205 x 117
Panel Cutout L x W (mm)	200 x 170
Bezel (mm)	232 x 205

The panel mounting of recorder is shown in figure 4 .



*Figure 4 - Panel Mounting*

## 6 ELECTRICAL INSTALLATION

### 6.1 WIRING DIAGRAM FOR RECORDER

The connection of the mains supply, battery backup and sensor are shown in figure 5. Refer the following table 3 for supply and sensor connection of the recorder.

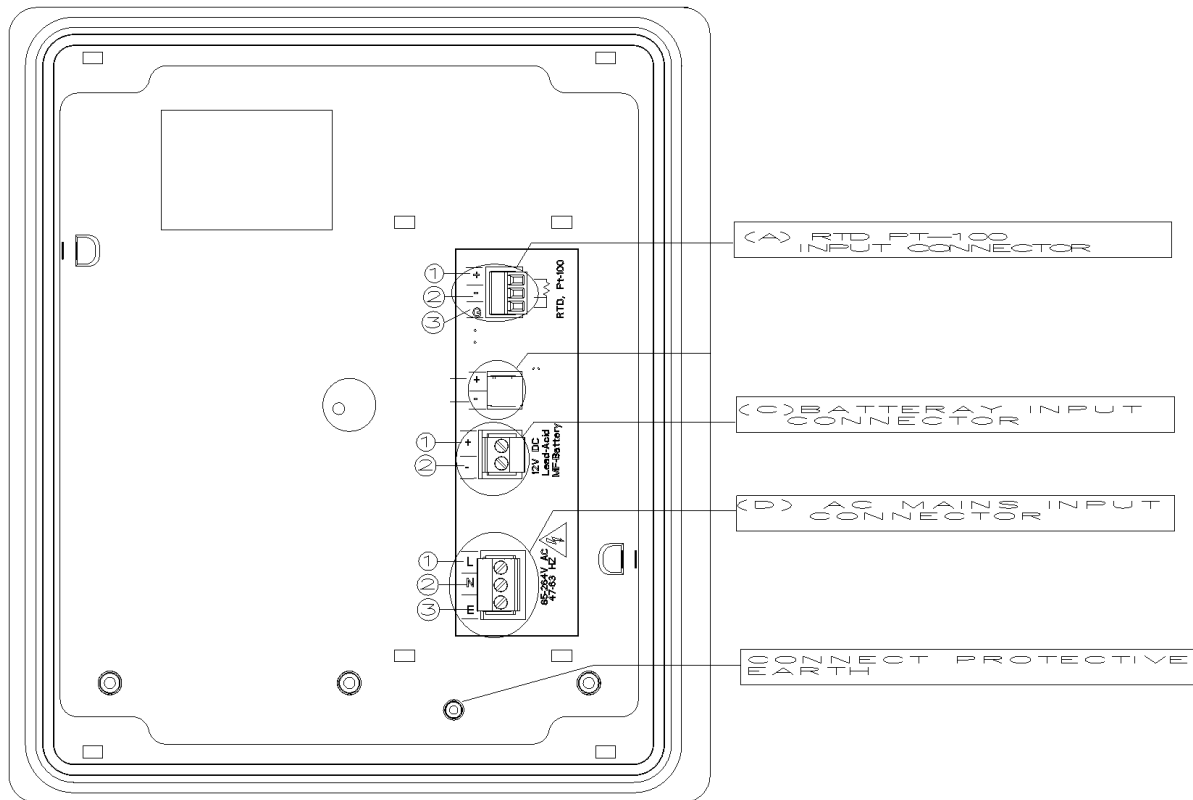

Figure 5 – Back panel view

Table 3 Connection Notations

Code	Connector Name	Pin Number of connectors		
		1	2	3
Sensor input	RTD (PT-100) 3-Wire	(+)	(-)	(G)
Battery	12 V DC Battery	(+)	(-)	
AC supply	85 – 264 V AC supply 47 – 63 Hz	Line (L)	Neutral(N)	Earth (E)

- The connections for Mains supply, battery terminals and sensor input are shown in Figure 5. As per the figure the live, neutral & earth from the mains cord are connected to L, N & E respectively.
- Ensure that the bared ends of the mains cord are fully inserted into the mains connector and no loose/poor connection.
- Also connect the Earth wire of the cable to the Earthing terminal given on body of the recorder.
- Table 2 shows the connection notations for Mains supply, battery terminals and sensor input.

#### Sensor Wiring:

- The connection of the recorder to a proper safety earth ground is essential. Such connection not only reduces the possibility of electric shock, but also provides the required return for the recorder line power filters.
- All local electrical codes of practice must be followed when installing any instrumentation. Please refer to the back panel of recorder to know the type of sensor input.
- When wiring RTDs, lead length and diameter must be chosen such that lead length are equal and that each lead exhibits no more than 10ohm resistance between the recorder and the RTD (Pt-100).
- For Input connections, high quality, low resistance contacts must be used which are suitable for dry operations.

## 6.2 FITTING THE PEN

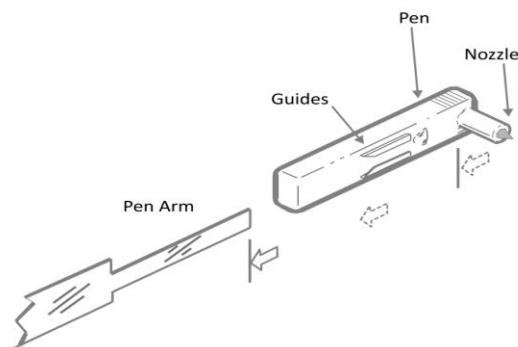

Figure 6 - Fitting / Replacing the Pen

#### While fitting/ replacing the pen follow the steps:

1. Slide the pen over pen arm until the tip of the arm passes through the guides and touches the nozzle.
2. A new pen may have burrs or obstructions in the guides. Apply enough force to clear the guides or use sharp knife to clean the guide beforehand.

#### Caution:

- Improper fitting of the pen may result in incorrect recording.
- An attempt to change the pen in Power On condition may result in damage to the recorder.

**Note:** It is recommended that the operator wear plastic gloves whilst handling pens to avoid ink contamination of the hands.

## 6.3 FITTING THE CHART

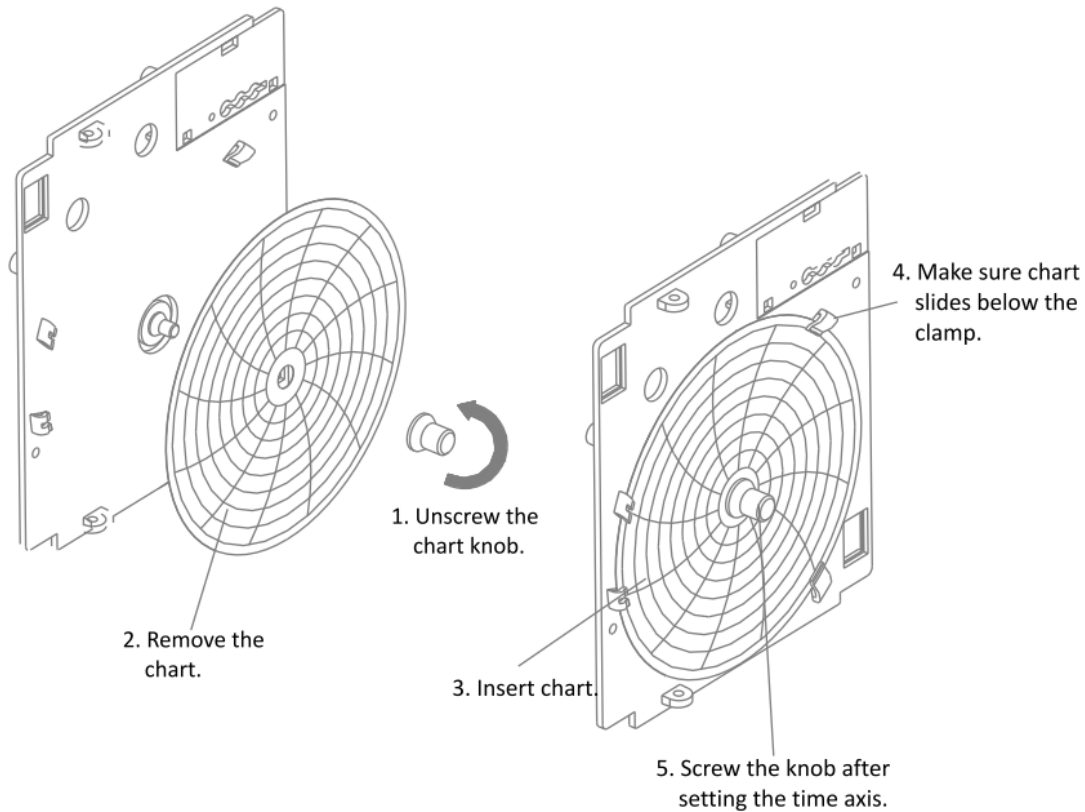

Figure 7 - Chart Fitting

### To replace the chart, follow the steps:

1. Open the door of the recorder.
2. Unscrew the chart knob as shown in figure 7.
3. Remove the chart.
4. Insert the new chart.
5. Screw the knob after setting time axis. Make sure that chart slides below the clamp as shown in Figure 7.

## 7 OPERATION

---

After ensuring that the wiring is proper and the pen and chart are fitted correctly, power on the recorder. The pen will move towards the center of the chart. After reaching the center of the chart, it will stop. After a while pen will move to the position on the chart as per the parameter value. The center of the chart is designated as range low of the recording. Whenever the measured value is less than the range low of the recorder, pen moves till zero and stops there. The full range of the chart is computed as follows.

Full range (100% of the chart) Value = Range low of the chart + Span of the chart.

e.g.: for the chart with the marking of -10 to + 40 with +40 marked at the center of the chart,  
Range Low = +40

Span = -50

Full range = 40 -50 = -10

For the recorder in example, when the parameter value is equal or less than -10, the pen will remain at full scale of the chart. When the parameter values are equal or more than +40, pen will remain at center of the chart.

### 7.1 FRONT PANEL

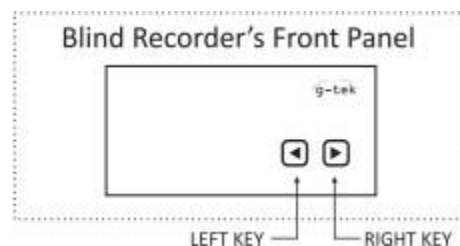





Figure 8 – Front panel of Chart Recorder without display

For recorders without display, two keys  &  are used to set various parameters like offset in the measurement and the mechanical calibration. The operator menu is entered using the two keys given on the front side. In this recorder, changing of Range low, Span and type of Sensor is not possible. The Blind recorder has only two keys and the various calibration parameters are set using these keys.

The  key is used to move the pen away from the center of chart whereas  is used to move the pen towards the center of chart.

## 7.2 MECHANICAL CALIBRATION

It involves setting of pens zero and pen full scale on chart, through the front panel keyboard. User can calibrate the Recorder by following the sequence as shown in figure 9.

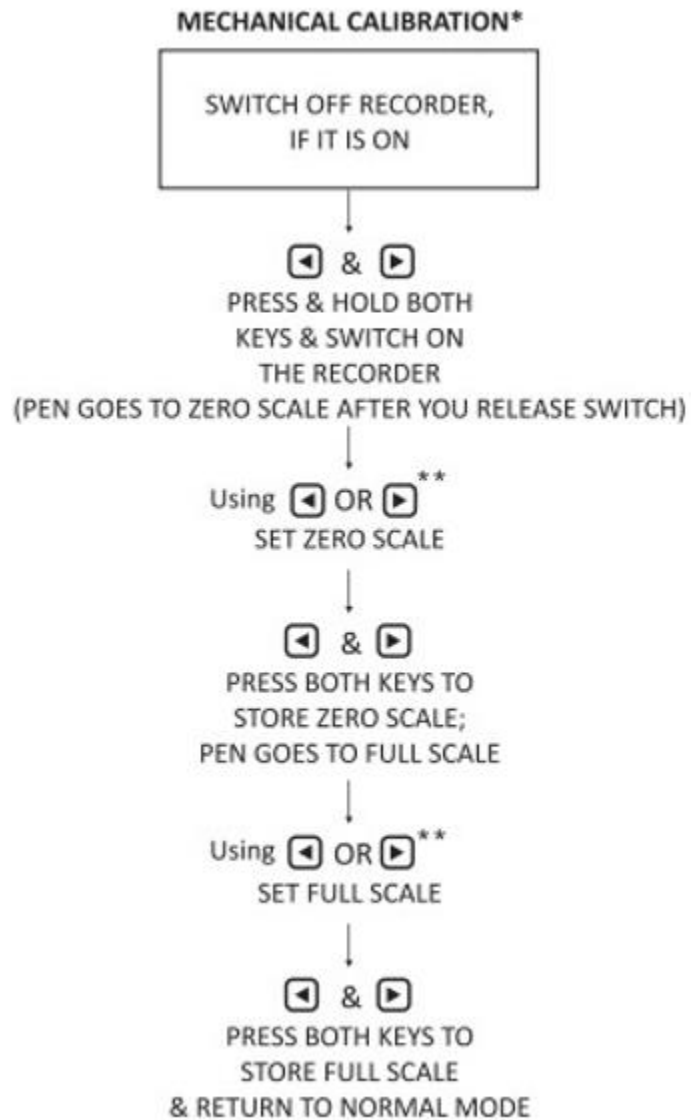

Figure 9 – Mechanical Calibration Menu

### 7.3 ELECTRICAL CALIBRATION

This setting involves aligning the pen to the known parameter value on chart, through the front panel keyboard. User can calibrate the Recorder by following the sequence in figure 10.

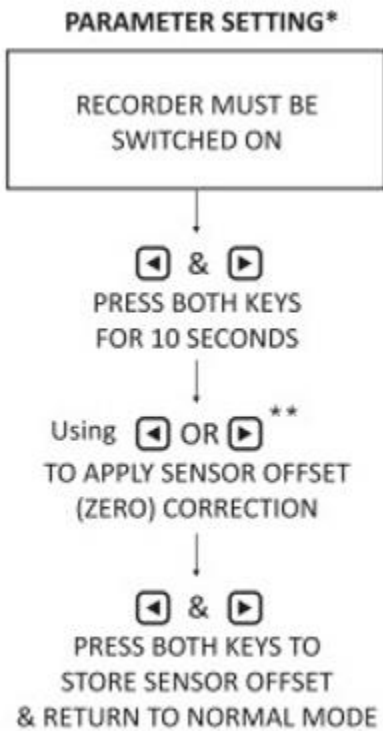

Figure 10 – Electrical Calibration Menu

## 8 FREQUENTLY ASKED QUESTIONS(FAQs)

---

Table 4 Frequently Asked Questions (FAQs)

PROBLEM	CORRECTIVE ACTION
<b>Power is ON but status LED is off.</b>	<ul style="list-style-type: none"> <li>➤ Check device switch whether it is ON or OFF</li> <li>➤ Check AC Mains or Battery Voltage .</li> </ul>
<b>Chart reading is different from the sensor input</b>	<ul style="list-style-type: none"> <li>➤ Check whether sensor is connected properly or not.</li> <li>➤ Sensor connection should be according to table 2.</li> <li>➤ Carry out mechanical calibration as per section 7.2.</li> </ul>
<b>Chart reading is not stable.</b>	<ul style="list-style-type: none"> <li>➤ Replace the sensor with fixed known input and verify it. If the reading is ok, then check and replace the sensor if required.</li> <li>➤ If problem persists, contact factory.</li> </ul>
<b>Pen is not marking on the chart.</b>	<ul style="list-style-type: none"> <li>➤ Pen might be dry, replace the Pen</li> <li>➤ Check pen arm pressure.</li> </ul>
<b>Pen does not respond to sensor input</b>	<ul style="list-style-type: none"> <li>➤ Check whether the input value is within the chart range.</li> <li>➤ If the input is within the range, carryout the mechanical calibration.</li> <li>➤ Chart range is not selected properly.</li> </ul>
<b>Pen movement is jerky</b>	<ul style="list-style-type: none"> <li>➤ Contact factory.</li> </ul>
<b>Chart does not move.</b>	<ul style="list-style-type: none"> <li>➤ Check if the chart knob is tightened properly.</li> <li>➤ If chart does not move still, then contact factory.</li> </ul>
<b>Pen ink is blotting on the paper.</b>	<ul style="list-style-type: none"> <li>➤ Pen arm pressure might be more, adjust it.</li> <li>➤ Remove the excess ink with the help of blotting paper.</li> <li>➤ Chart paper has absorbed moisture. Put in desiccator and remove the moisture.</li> </ul>
<b>Device not Working on battery.</b>	<ul style="list-style-type: none"> <li>➤ Battery voltage is not enough.</li> <li>➤ Check battery polarity.</li> </ul>

## 9 STANDARD ACCESSORIES

---

Charts Pack of 30

Pens Pack of 5: - 1 number

Panel Mounting Clamps: - 2 numbers

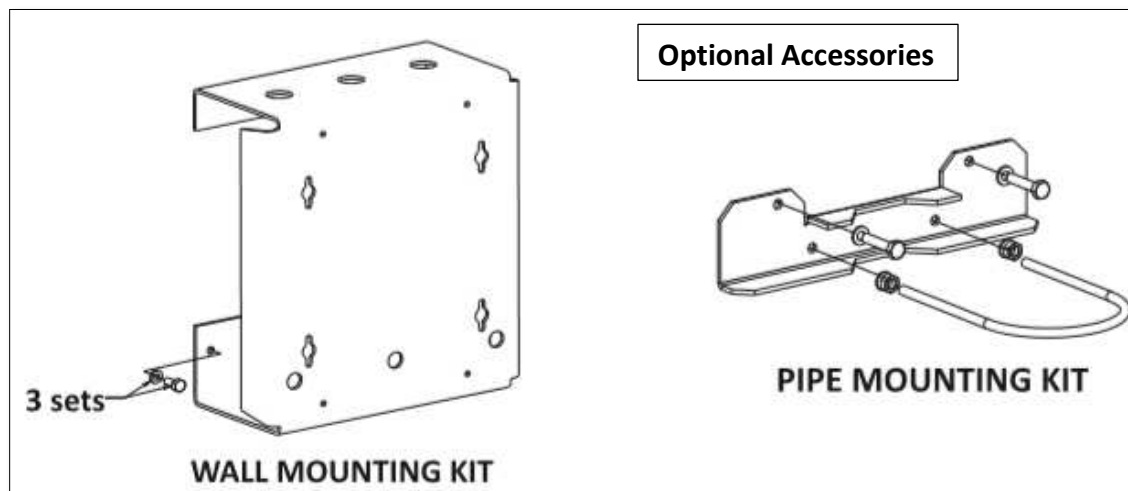
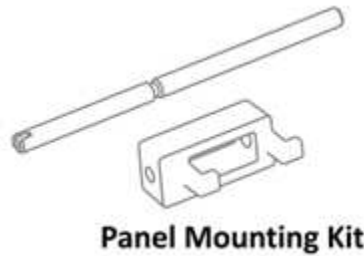
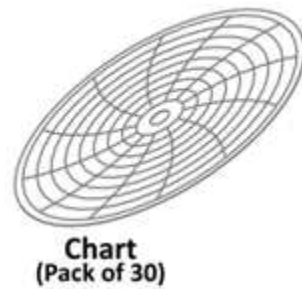
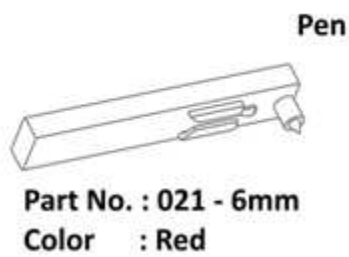

Figure 11 – Accessories

# 10 ORDER CODE

The Order code for the chart recorder is as below:

Table 5 Order code

CR		PD		PS		RE		PI		-	CT		R		CS		S	
C=Chart Width R=Recorder type		P= Pen, TP= Thermal-Pen, D= Display, ND =No Display		PS = Power Supply TS - Transmitter Supply		RE = Relay		PI = PC Interface			CT - Chart Type		R=Range		CS=Chart Speed		S=Sensor Type	
CR		PD		PS		RE		PI			x	x	R		CS		S	
1	CR4-NU	0	1P ND	0	85-264 V CE	0	None	0	None				0	PG	0	P. G	0	Uni.
2	CR6-NU	1	1P D	1	12-15V DC	1	1	1	RS-232				1	Fixed, Specify	1	4H	1	RTD
		2	2P D	4	85-264V CE BB	2	2	2	RS-485				2		2	8H	2	4-20mA
		3	3P D	5	85-264V CE With TS	3	3	3	USB				3		3	24h	3	0-20mA
		4	4P D	7	85-264V CE BB With TS	4	4	4	TCP/IP				4		4	7D	4	0-1 Volt
		5	1PS ND	8	24 V	5	5	6	Wi-Fi				5		5	20mm/HR	5	TC-J
		6	1P LCD			6	6						6		6		6	TC-K
		7	1TP LCD										7		7		7	TC-R
		8	1P D BBR										8		8		8	TC-S
													9	Other	9		9	TC-T
																A		0-10V DC
																B		0-5V DC

