

OPERATING MANUAL

CR-2010^{Pro}

CR-2010 PRO Series 6" Open Frame Circular Chart Recorder For OEM's Model No.: 9994x



Manufacturers of :

- Circular Chart Recorders
- Inkless Recorders
- Paperless Recorders
- Scanners & Data Loggers
- Networked Data Loggers
- Application Software
- WHO PQS Qualified Data Loggers
- Vaccine Series Data Loggers

G-TEK CORPORATION PVT. LTD.

"Gunaji House"
Plot No. 25/1, Besides Status Bungalow,
Padra Road, Vadodara – 391410.
tel.: +91-98245 24140
e-mail: info@gtek-india.com
url: www.gtek-india.com

CONGRATULATIONS

Thank You for choosing G-Tek Recorders for your recording needs.

The all new updated CR2010 Pro series of recorders owes much to the user feedback. While maintaining the ease of operation of CR2010 Pro, the efforts have been made to further simplify the operation and improve overall look and feel. The recording range, chart speed and calibration factors are all user programmable(configurable) from the front panel keyboard. Polynomial based linearization for most of the known inputs, along with high resolution a/d makes it one of the high accuracy recorders in its category. A universal input version offers field selection of sensor types. The mechanical and electrical designs have been optimized for ruggedness and ease of operation. These instruments will undoubtedly prove to be a valuable asset at your plant.

Before installing and operating the instrument, please take time to go through the manual, which will enable you to get the most out of your recorder.

Our new series owes much to the feedback received from our customers and we shall always welcome your suggestions and comments on any aspect of our products.

G-Tek Corporation Pvt Ltd

Vadodara

CALIBRATION ACCURACY

This product was thoroughly tested to ensure compliance with the published specifications. The G-Tek further certifies that all instruments used in production and final test are regularly inspected to maintain accuracy of calibration and are traceable to the National or International standards, to the extent allowed by that organization's calibration facility and to the calibration facilities of other international standards organization members. The user should be satisfied that the performance of the product as received meets expectations and as part of a program of planned maintenance, should be periodically check calibration accuracy against standards.

WARRANTY

This product is warranted against defects in materials and workmanship for a period of one year from the date of shipment. During the warranty period, G-Tek will, at its option, either repair or replace products which prove to be defective.

WARRANTY SERVICE

Warranty service at the buyer's facility can be provided only under prior agreement by the manufacturer or its representative, and the buyer may be required to pay round-trip travel expenses. In all cases, the buyer has the option of returning the product for Warranty service to a facility designated by the G-Tek or its representatives. The buyer shall prepay shipping charges for products returned to a service facility, and the G-Tek or its representative shall pay for the return of the product to the buyer. However, the Buyer shall pay all the shipping charges, duties and taxes for products returned to G-Tek from outside of Vadodara, India.

LIMITATION OF WARRANTY

The foregoing warranty shall not apply to defects arising from: Improper or inadequate maintenance by the buyer, Improper or inadequate site preparation, Unauthorized modification or misuse, Operation of the product in unfavorable environments, especially, high temperature, high humidity, corrosive or other damaging atmospheres. In addition, G-Tek does not warrant any damage that occurs as a result of the Buyer's circuit or any defects that result from Buyer-supplied products.

EXCLUSIVE REMEDIES

The remedies provided are herein the buyer's sole and exclusive remedies. G-Tek shall not be liable for any direct, indirect, special incidental or consequential damages (including lost profits) whether based on warranty, contract, tort, or any other legal theory.

DISCLAIMER





G-Tek makes no other warranty expressed or implied, whether written or oral with respect to this product and specifically disclaims any implied warranty or condition of merchantability, fitness for a particular purpose or satisfactory quality.

NOTICE

The information contained in this document is subject to change without notice. G-Tek Corporation makes no warranty of any kind with regards to this material, including, but not limited to, the implied warranties of merchantability and fitness for a particular purpose. G-Tek Corporation shall not be liable for errors contained herein or for incidental or consequential damages in connection with the furnishing, performance, or use of this material. No part of this document may be photocopied, reproduced, or translated to another language without the prior written consent of G-Tek.

SYMBOL DEFINATIONS

The following table lists those symbols used in this document to denote certain conditions.

	<p>This caution symbol on the equipment refers to the user to the Product Manual for additional information. This symbol appears next to the required information in the manual.</p>
	<p>Warning Personal Injury : Risk of electrical shock. This symbol warns the user of a potential shock hazard where HAZARDOUS LIVE voltage greater than 30 Vrms, 42.4V peak or 50Vdc may be accessible. Failure to comply with these instructions could result in death or serious injury.</p>
	<p>Attention Electrostatic Discharge (ESD) hazards. Observe precautions for handling electrostatic sensitive devices.</p>
	<p>Protective Earth Terminal. Used for non-safety purpose such as noise immunity improvement. This connection shall be bonded to protective earth at the source of supply in accordance with national local electrical code requirements.</p>
	<p>Earth Ground. Functional earth connection. NOTE : This connection shall be bonded to protective earth at the source of supply in accordance with national and local electrical code requirement.</p>

SAFETY NOTES

WARNING

Any interruption of the protective conductor inside or outside the apparatus, or disconnection of the protective earth terminal is likely to make the apparatus dangerous under some fault conditions. Intentional interruption is prohibited.

Note: In order to comply with the requirements of safety standard BS EN61010, the recorder shall have one of the following as a disconnecting device, fitted within easy reach of the operator, and labeled as the disconnecting device.

- a. A switch or circuit breaker which complies with the requirements of IEC947-1 and IEC947-3
- b. A separable coupler which can be disconnected without the use of a tool
- c. A separable plug, without a locking device, to mate with a socket outlet in the building.

1. Before any other connection is made, the protective earth terminal shall be connected to a protective conductor. The mains (supply voltage) wiring must be terminated within the connector in such a way that, should it slip in the cable clamp, the Earth wire would be the last wire to become disconnected.
2. Before switching on the apparatus, ensure that the connected supply voltage is compatible with the apparatus. Ensure that only fuses with the required rated current and of the specified type are used for replacement. The use of makeshift fuses and the short-circuiting of fuse holders is prohibited.
3. Any adjustment, maintenance and repair of the opened apparatus under voltage, should be avoided as far as possible and, if inevitable, shall be carried out only by a skilled person who is aware of the hazard involved. When the apparatus is connected to its supply, terminals may be live, and the opening of covers or internal assemblies (except for those designed for access to be gained by hand) is likely to expose live parts. The capacitors and other components on the circuit board may temporarily retain a hazardous charge after the supply voltage has been disconnected. These capacitors and other parts must not be touched for at least 10 seconds after supply voltage disconnection.
4. Where conductive pollution (e.g. condensation, carbon dust) is likely, adequate air conditioning / filtering / sealing etc. must be installed in the recorder enclosure.
5. Signal and supply voltage wiring should be kept separate from one another. Where this is impractical, shielded cables should be used for the signal wiring.
6. This apparatus has been designed and tested in accordance with applicable safety standards and is supplied in a safe condition. This instruction manual contains some information and warnings which have to be followed by the user to ensure safe operation and to retain the apparatus in safe condition. If the equipment is used in a manner not specified by the manufacturer, the protection provided by the equipment might be impaired. Whenever it is likely that protection has been impaired, the unit shall be made inoperative, and secured against accidental operation. The manufacturer's nearest service center should be contacted for advice.

* A full definition of 'Hazardous' voltages appears under 'Hazardous live' in BS EN61010. Briefly, under normal operating conditions, hazardous voltages are defined as being > 30V RMS (42.2V peak) or > 60V dc.

CONTENTS

Contents.....	1
1 List of Figures	2
2 List of Tables	2
3 Introduction	3
3.1 Manual Layout	3
3.2 Recorder Description	3
3.3 Features	4
3.4 Unpacking and Inspection of Recorder.....	4
4 Installation	7
4.1 Environmental Conditions For Recorder.....	7
4.2 Overall Mechanical Dimensions.....	8
4.3 Mounting of the Chart Recorder.....	10
4.4 Electrical Installation.....	11
4.4.1 General Information	11
4.4.2 Wiring Diagram of Sensor	12
4.4.3 Mains Supply Connection	13
4.5 Fitting the Chart	14
5 Operation and Configuration	15
5.1 Front Panel of Recorder	15
5.2 LED Status Indication	16
5.3 Chart range, Speed and Alarm Selection Menu.....	16
5.3.1 Alarm Operation	16
6 Calibration.....	19
6.1 Mechanical Calibration	19
6.2 Electrical Calibration (Offset).....	20
6.3 Pen Park	21
7 Battery Installation/Replacement.....	22
7.1 Battery Change.....	22
7.2 Battery Life.....	22
8 Troubleshooting Guide	24

9	Accessories.....	25
9.1	Standard Accessories	25
10	Specifications	26
11	Order Code.....	29

1 LIST OF FIGURES

Figure 1	– Front and Back View of Chart Recorder.....	5
Figure 2	– Front and Back View of Chart Recorder with Clamp for Hinge.....	6
Figure 3	- Environmental Conditions	7
Figure 4	- Overall Mechanical Dimensions of Chart recorder without Clamps	8
Figure 5	- Overall Mechanical Dimensions of Chart recorder with Clamps.....	9
Figure 6	- For Panel Mounting of the recorder	10
Figure 7	- Sensor and Mains connection.....	13
Figure 8	- Chart Fitting	14
Figure 9	- Recorder Front Panel with multi-purpose keys	15
Figure 10	- Chart Parameters Settings LED Indication	17
Figure 11	- Chart Parameters settings sequence	18
Figure 12	- Mechanical Calibration sequence.....	19
Figure 13	- Offset Settings sequence	20
Figure 14	- Pen-Park Function sequence	21
Figure 15	- Battery Replace	22
Figure 16	- Standard Accessories	25

2 LIST OF TABLES

Table 1	- Manual Layout.....	3
Table 2	- Connection Notations for sensor input.....	13
Table 3	- Connection Notations for Power Supply.....	13
Table 4	- LED Status Indication.....	16
Table 5	- Troubleshooting Guide.....	24
Table 6	- Specification of Chart Recorder	26
Table 7	- Programmable(configurable) Chart Ranges.....	28
Table 8	- Available Chart(s) and their ranges.....	28
Table 9	- Sensor Type and Range	28
Table 10	- Order code	29

3 INTRODUCTION

This manual is written to familiarize the user with the installation and operation of the Smart Chart series of circular chart recorders. These recorders are capable of plotting one channel using color inks or pressure sensitive pen.

3.1 MANUAL LAYOUT

This manual is divided into a number of sections for quick and easy reference.

Table 1 - Manual Layout

Section 1 Introduction	Contains outline of the manual, brief description about the recorder, Optional features available and information about unpacking of the product.
Section 2 Installation	Contains details about installation of the product vis-a-vis mechanical and electrical aspects
Section 3 Operation and Configuration	Contains details of the front panel keyboard and various parameters that user can set for configuration of recorder.
Section 4 Calibration	Description of the mechanical, electrical calibration and pen park procedure for the recorder.
Section 5 Battery Installation	Contains the battery installation/ replacement procedure and battery life related precautions.
Section 6 Troubleshooting guide	Details of most frequently encountered questions and their answers.
Section 7 Accessories	Contains the list of standard accessories for the recorder along with their part nos.
Section 8 Specifications	Contains detailed specifications of the recorder.
Section 9 Ordering Code	Contains details of order code to enable the user to find out the installed options by comparison with the code on recorder.

3.2 RECORDER DESCRIPTION

The CR-2010 Pro series recorder comes as either one or two pen continuous marking on circular chart. This chart recorder is specially tailored to work on Mains+ Battery operated options. The chart recorder comes with chart size 6", single input channel, status LEDs and three multipurpose keys without display. The pen marks continuously on the chart as per the speed set by the user

for completion of full revolution. The status LEDs and multipurpose keys empower users to easily configure the unit.

3.3 FEATURES

The following features are available for this series of recorders.

- Inkless pressure pen recorder
- Battery Backup
- Fitting Clamp (Optional)

Please refer to the product code to know about installed options in your recorder.

3.4 UNPACKING AND INSPECTION OF RECORDER

The chart recorders are dispatched in a recyclable, environment friendly package, specially designed to give adequate protection to the recorder against transit damage. If the Open frame shows any signs of damage, it should be opened immediately for inspection of the contents. If there is evidence of the damage, please do not operate the equipment. Contact our local representative for further information. If no apparent damage to the product is seen, please remove all accessories and documents from the box. Figure 1 and 2 shows the front view of the Open frame chart recorder with the parts indication. Inspect the recorder for any damage. Inspect the recorder for mechanical integrity and close the door. If the recorder is not to be used immediately, please re-pack it in its original packaging. If the recorder is to be used immediately, please use it as per the following instructions.

Please preserve the original packaging along with all internal material for future transport requirements.

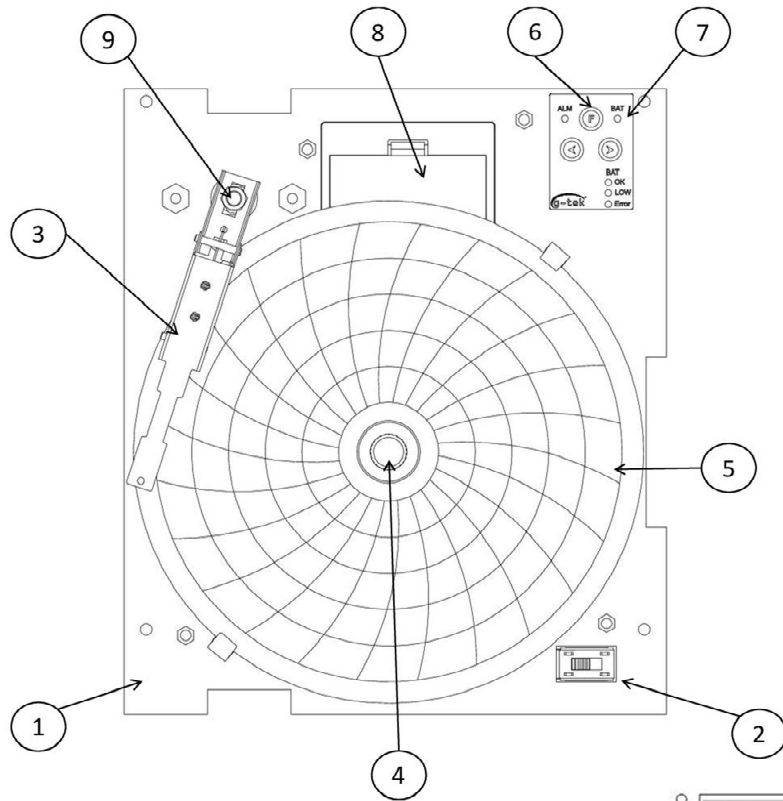

1. Chart Plate
2. On/Off Switch
3. Pen
4. Chart Knob
5. Chart
6. Keyboard
7. LED Indicator
8. Battery box
9. Pen Arm

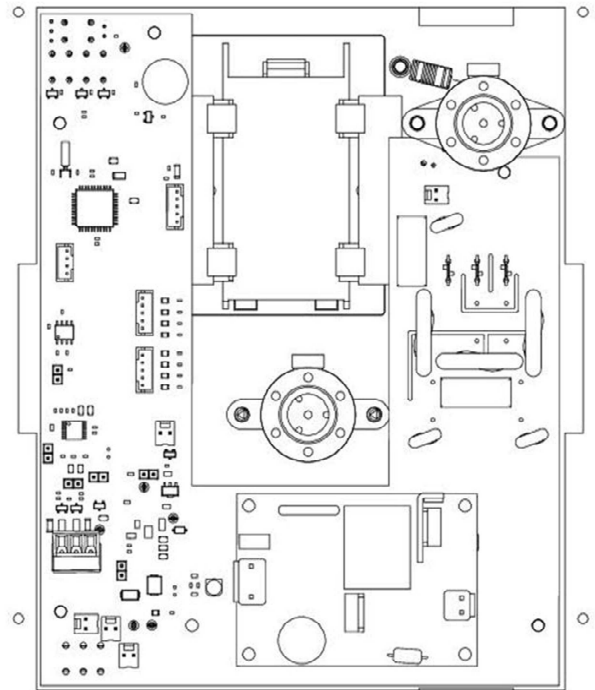
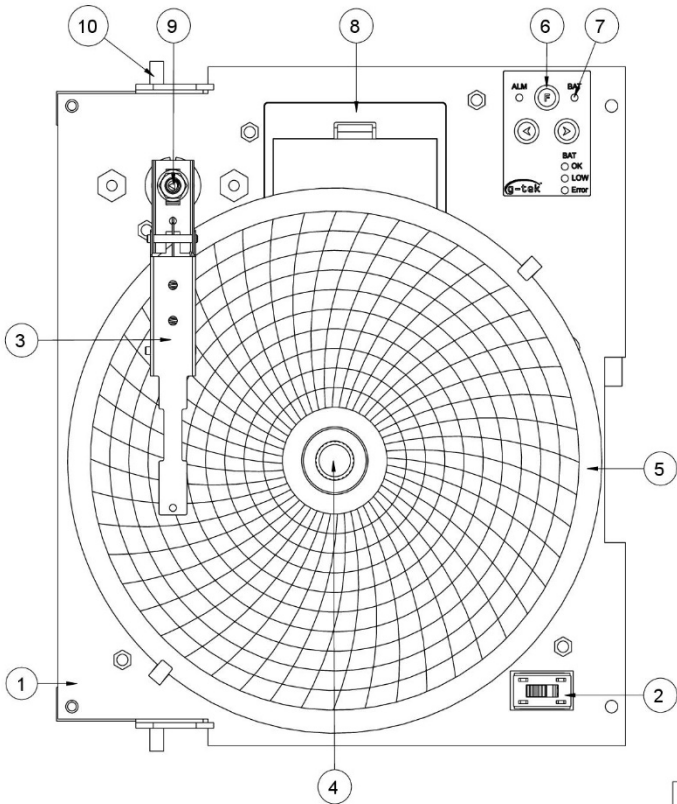

Figure 1 – Front and Back View of Chart Recorder



- 1. Chart Plate
- 2. On/Off Switch
- 3. Pen
- 4. Chart Knob
- 5. Chart
- 6. Keyboard
- 7. LED Indicator
- 8. Battery box
- 9. Pen Arm
- 10. Clamp for Hinge

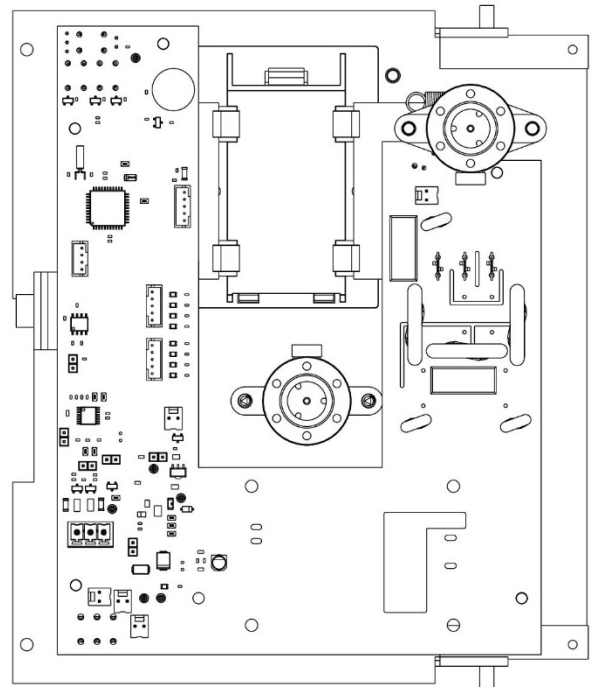

Figure 2 – Front and Back View of Chart Recorder with Clamp for Hinge

4 INSTALLATION

4.1 ENVIRONMENTAL CONDITIONS FOR RECORDER

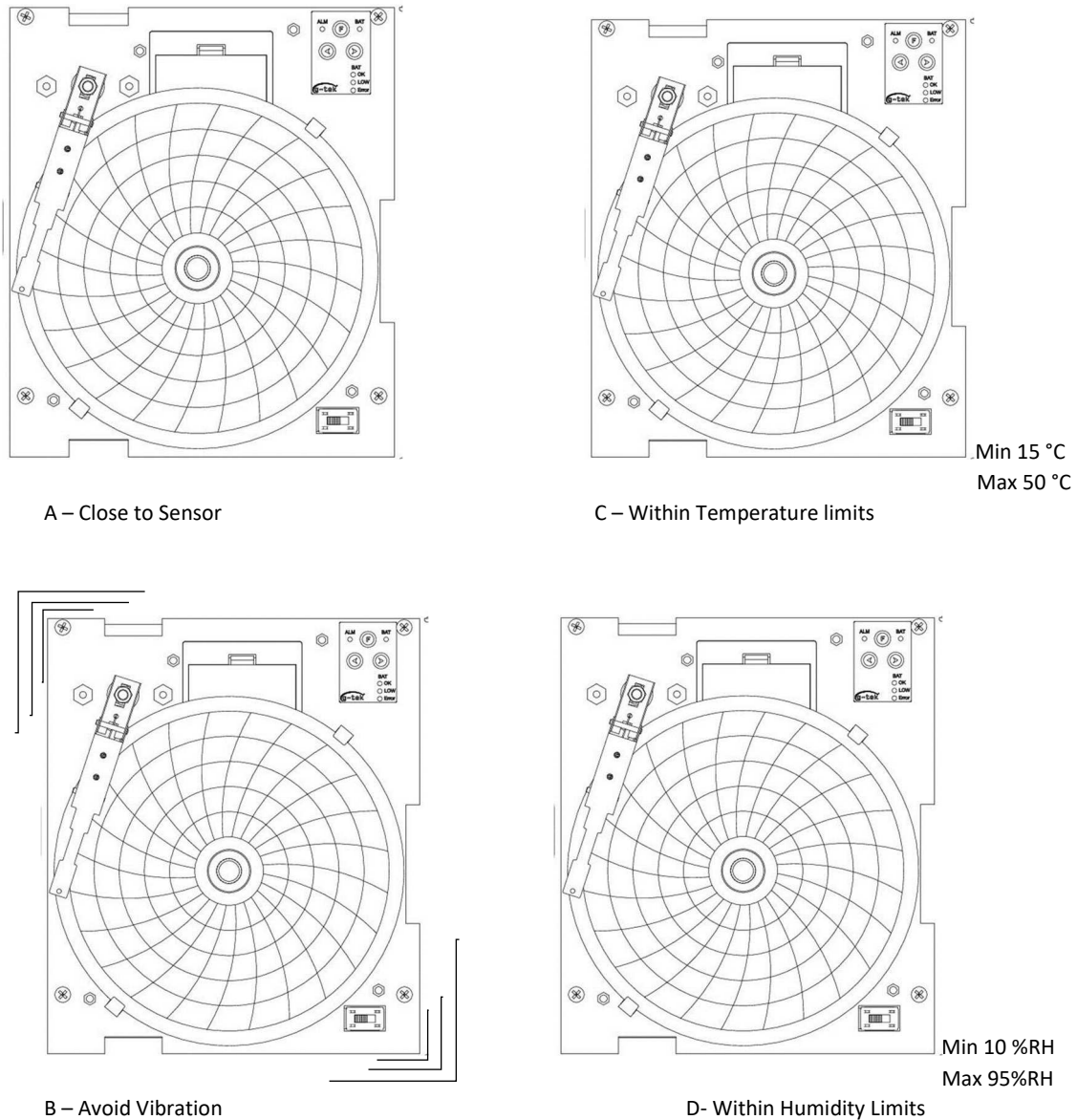

Figure 3 - Environmental Conditions

Environmental Conditions:

Recorders must be used with proper environmental conditions for better operation. The environmental conditions are shown in figure 3.

Attention

Select a location away from strong electrical and magnetic field. If this is not possible, particularly in application where mobile communication recorder is expected to be used, screened cables within earthed (grounded) metal contact must be used as shown in above figure 2B.

4.2 OVERALL MECHANICAL DIMENSIONS

1. The figure 4 shows the overall dimensions of the Chart recorder with mounting detail dimensions

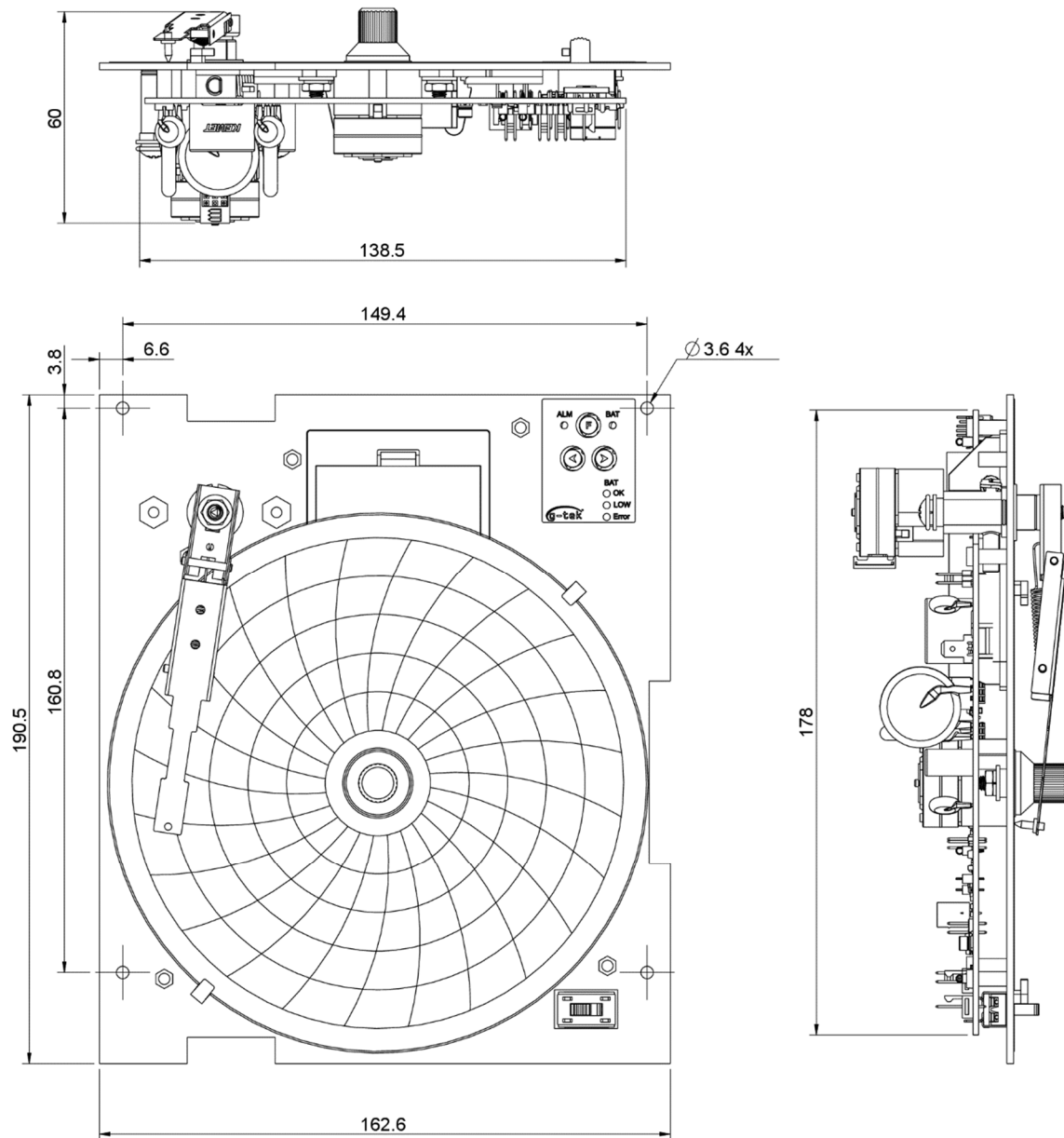

Figure 4 - Overall Mechanical Dimensions of Chart recorder without Clamps

2. The figure 5 shows the overall dimensions of the Chart recorder with clamps for hinge mounting details dimensions.

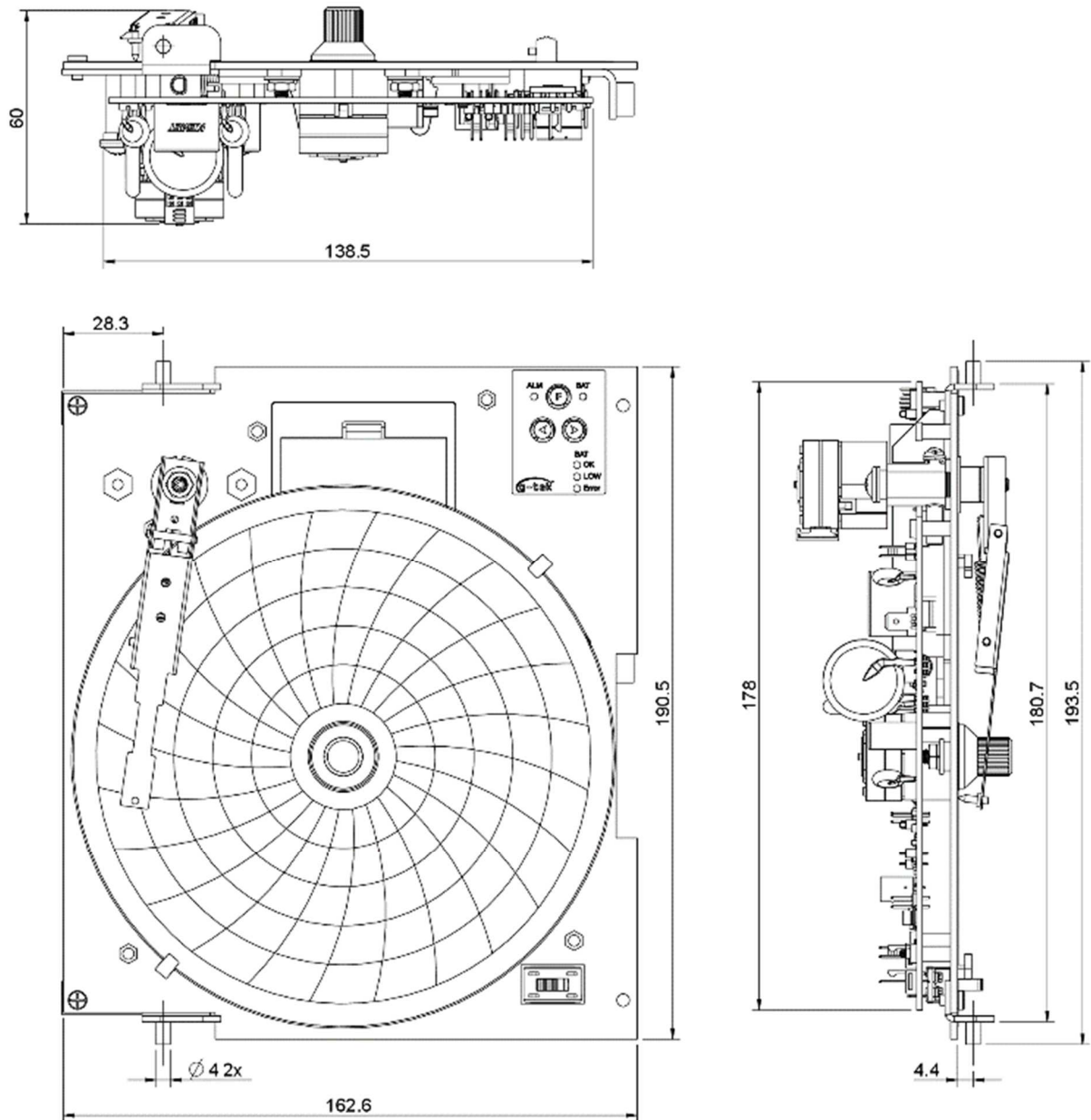

Figure 5 - Overall Mechanical Dimensions of Chart recorder with Clamps

Note: All the dimensions shown in the figure 4, 5 are in mm.

4.3 MOUNTING OF THE CHART RECORDER

The chart recorder can be panel-mounted by either screwing the chart plate at its four corners or using the clamp with hinge option, as shown in figure 6. The dimensions for the mounting screws and hinge, relative to the chart plate, are provided in figures 4 and 5 in the previous section.

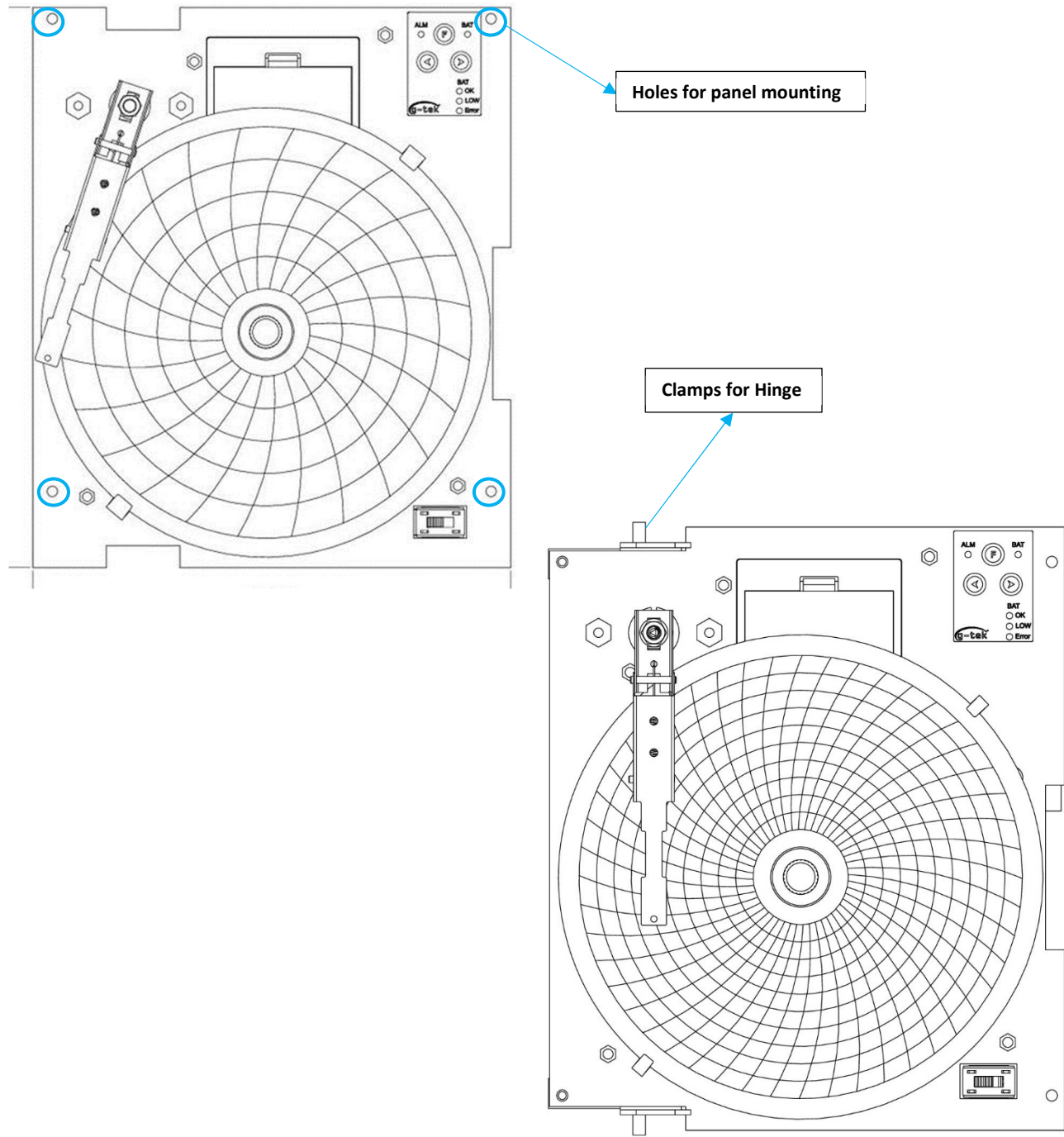

Figure 6 - For Panel Mounting of the recorder

4.4 ELECTRICAL INSTALLATION

4.4.1 General Information



Warnings

To comply with Underwriter Laboratories (UL) and Canadian Standards Association (CSA) certification, please route signal leads and power cables in earthed (grounded), flexible metal conduit. Use the protective ground stud at the back of recorder J; (NOT the terminal module ground connection) to ground the flexible metal conduit.

- Instruments not fitted with the optional internal on/off switch and fuse should have a disconnecting device such as a switch or a circuit breaker, conforming to local safety standards, connected to it at the time of final installation. Such a device must be fitted in close proximity of the instrument, within easy reach of the operator and should be marked clearly as the disconnecting device for the instrument.
- Remove all power from supply, relay, any powered control circuits and high common mode voltages before accessing or making any connections.
- Use cables which are appropriate for the load currents. The terminals accept cables up to 14AWG (2.5mm²).
- The instrument and all inputs and outputs conform to Mains Power Input Insulation Category II.
- All connections to secondary circuits should have basic insulation.
- After installation, there should be no direct access to live parts e.g., terminals.
- Terminals for external circuits are for use only with equipment with no accessible live parts.
- If the instrument is used in a manner not specified by the Company, the protection provided by the equipment may be impaired.
- All equipment connected to the instrument's terminals should comply with local safety standards (IEC 60950, EN601010-1)

NOTE:

In order to ensure optimum performance of the recorder, the practice of proper installation of wiring should be followed strictly. Failure to do so can result in problems such as, but not limited to, loss of configuration to component failure, caused by transmitted or radiated electrical noise. Proper consideration must be given to local noise sources and appropriate steps taken to suppress the noise and minimize any potential problems. Among the most common sources of noise are: Relays, SCRs, valve solenoids, electric motors, power line disturbance, wire-to-wire coupling, electrostatic discharge (ESD) and radio-frequency interference (RFI).

To achieve the optimum results, please consider the following:

1. Low level signal wiring such as that associated with thermocouples, RTDs and current loops should always be kept separate from power and control output wiring.
2. Signal input wiring should be twisted pairs/triplets etc. The conductors should be stranded rather than solid in construction. All signal wiring should use ground-shielded wires or be routed through grounded conduit to minimize the effects of RFI and ESD.
3. Special care should be taken when wiring to relay or solenoid coils, as large transients are produced when coils (or any other inductive loads like motors or arc welding equipment's etc.) are switched on. This problem can be eliminated by the use of suitable suppression devices across the coil. Coil transients can also be transmitted through the air, so the recorder itself should be mounted as far away as possible from power control devices and/or wiring.
4. When line power is poorly regulated and / or subject to voltage surges or transients, consideration should be given to the use of a line conditioning/transient suppressing line power regulator. Process control motors, valves, relays and heaters should not be connected to the same power lines that are used for instrumentation.
5. The connection of the recorder to a proper safety earth ground is essential. Such a connection not only reduces the possibility of electric shock, but also provides the required return for the recorder line power filters.
6. All local electrical codes of practice must be followed when installing any instrumentation.
7. If wall- or pipe-mounting to NEMA 4X (IP65) hose down standard is required, suitable cable glands must be used to prevent water ingress.

4.4.2 Wiring Diagram of Sensor

All the connections are made on the back panel. All the connectors are removable plugs. The mains connector is bigger than the sensor connector. The connections are shown in figure 7.

- All local electrical codes of practice must be followed when installing any instrumentation. Please refer to the back panel of the recorder to know the type of sensor input.
- When wiring RTDs, lead length and diameter must be chosen in a way that wire's lead length is equal and that each lead exhibits no more than 10 ohms resistance between the recorder and the RTD (Pt-100).
- For Input connections, high quality, low resistance contacts must be used, which are suitable for dry operations.

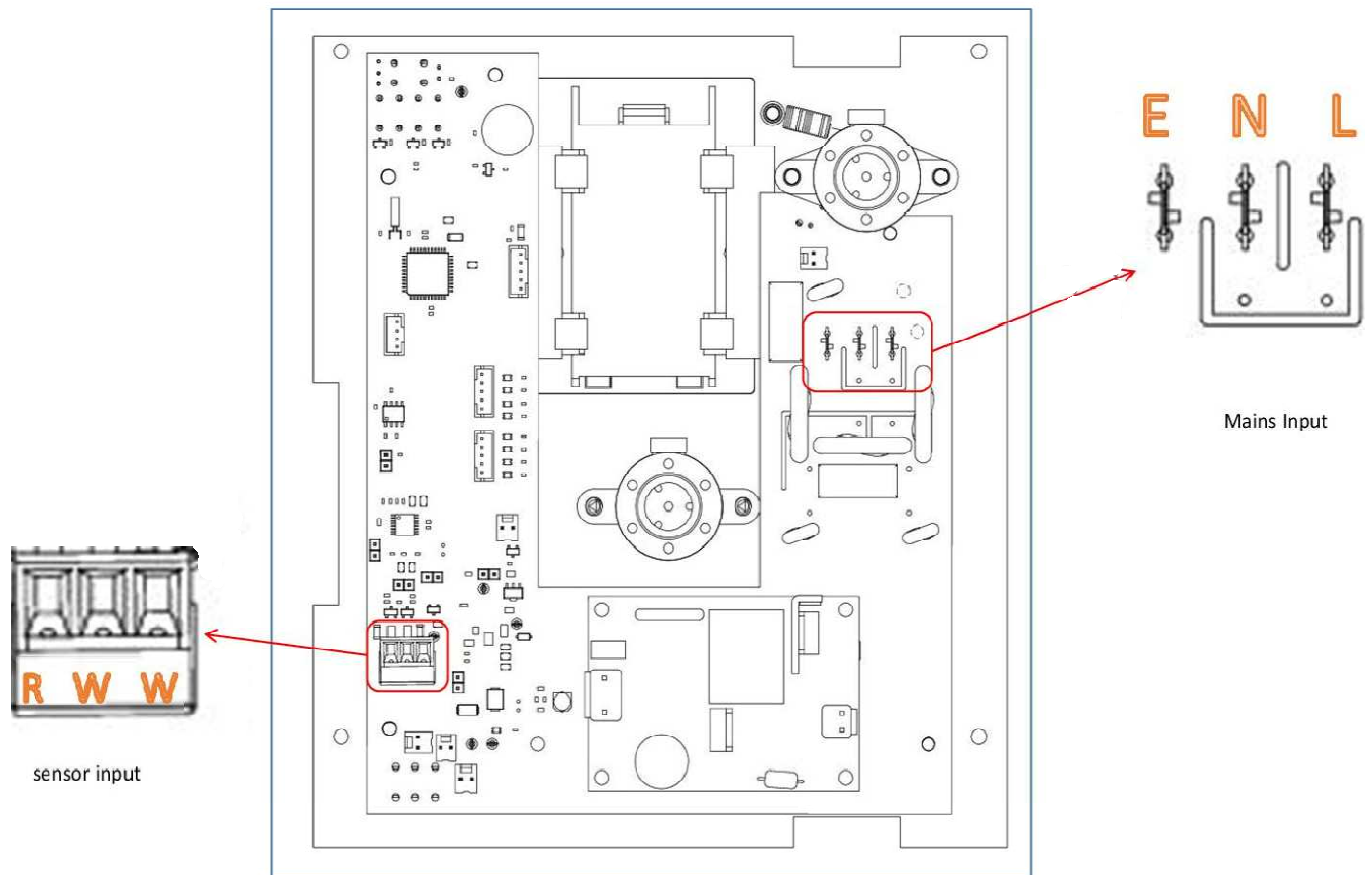

Figure 7 - Sensor and Mains connection

Table 2 - Connection Notations for sensor input

Code	Connector Name	Pin Number of connectors		
		R	W	W
Sensor input	RTD (PT-100) 3-Wire	Red	White	White

4.4.3 Mains Supply Connection

The connection for Mains supply is shown in figure 7. As per the figure, the live, neutral & earth from the mains cord are connected to terminals marked L, N & E, respectively. Ensure that the exposed ends of the mains connector are not exposed and that there is no loose/improper connection.

Table 3 - Connection Notations for Power Supply

Code	Connector Name	Pin Number of connectors		
		L	N	E
Input AC supply	LNE 3 wire	(Line) Red	(Neutral) Black	(Earth) Green

4.5 FITTING THE CHART

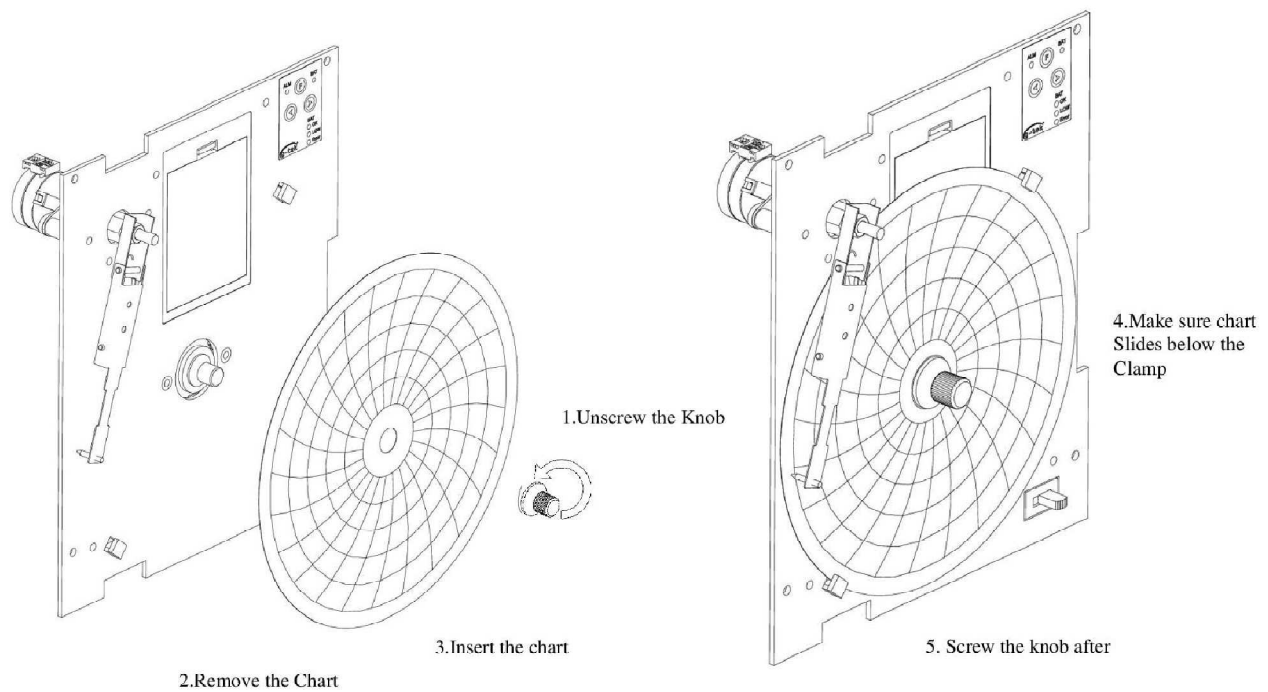

Figure 8 - Chart Fitting

To replace the chart, follow the steps:

1. Open the door of the recorder.
2. Park the pen on full scale position.
3. Unscrew the chart knob as shown in figure 8.
4. Remove the chart.
5. Insert the new chart.
6. Screw the knob after setting time axis. Make sure that chart slides below the clamp as shown in Figure 8.

5 OPERATION AND CONFIGURATION

After ensuring that the wiring is proper and the pen and chart are fitted correctly, power on the recorder. BAT LED blink in Green color every 2 seconds (approximately).

The pen will move towards the center of the chart. Upon reaching the center of the chart, it will take a pause and moves to the position as per the parameter value. The center of the chart is designated as range low of the recording. Whenever the measured value is less than the range low of the recorder, the pen moves till zero (Range Low) and stops there. The full range of the chart is computed as follows:

Full range (100% of the chart) Value = Range low of the chart + Span of the chart.

e.g.: for the chart with the marking of +40 to -10 with +40 marked at the center of the chart,
Range Low = +40

Span = -50

Full range = 40 -50 = -10

For the above example, recorder will function as, when the parameter value is equal or less than -10, the pen will remain at full scale of the chart. When the parameter values are equal to or more than +40, pen will remain at center (Range Low) of the chart.

5.1 FRONT PANEL OF RECORDER

For the chart recorder, three multipurpose keys are used to set various parameters like offset in the measurement, pen park, chart range selection and the Mechanical calibration.

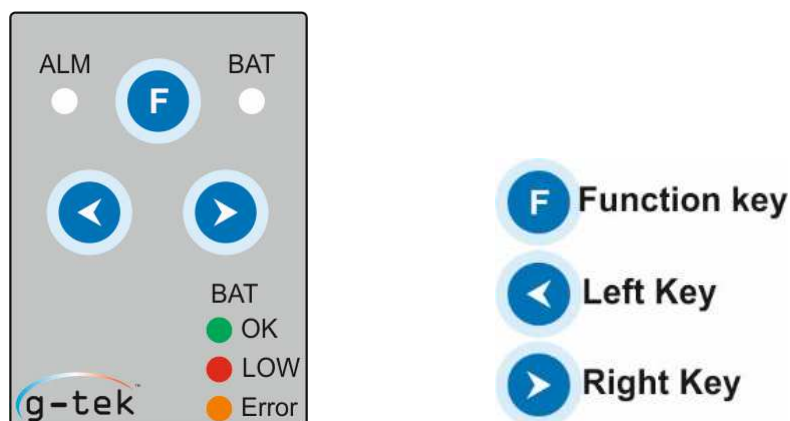





Figure 9 - Recorder Front Panel with multi-purpose keys

5.2 LED STATUS INDICATION

Table 4 - LED Status Indication

ALM LED	Description
	When the temperature High/Low Alarm is generated, then RED LED blinks every 2 seconds.
BAT LED	Description
	Normal Operation of the recorder is indicated by Green LED blink at every 2 seconds.
	When battery is low, LED will blink in Red color instead of Green at every 2 seconds.
	When the recorder is in Error/abnormal condition or Sensor disconnected Yellow LED blink every 2 seconds; and for Limit Not achieved it remains continuously ON.

5.3 CHART RANGE, SPEED AND ALARM SELECTION MENU

The chart recorder comes with default required Chart range, chart speed and sensor type setting. If the user wants to update these parameters, then follow the Steps as shown in figure 10.

Sequence for changing the chart range, chart speed and sensor type:

- Open the door and unscrew the countersunk screw on the center right side of the chart plate.
- Open the chart plate like the door where the inside PCB is visible.
- Locate the 8 LEDs on the PCB – refer to figure 10.
- Press the Left + Right key at power-up for the goes to main menu, then press Function key for chart selection menu.
- Use Left or Right keys to toggle the LED to select appropriate chart.
- Press Left + Right key to save the chart range and shift to chart speed selection.
- Use Left or Right keys to toggle the LED and select appropriate speed.
- Press Left + Right key to save the chart speed and shift to Alarm enable/disable selection.
- Use Left or Right keys to toggle the LED and select appropriate Alarm Buzzer selection.
- then Left + Right key to confirm all selections.

NOTE: If any key press is not detected within 30 seconds, then the recorder automatically exits from the menu and recorder will starts normal operation

5.3.1 Alarm Operation

- 1) **Chart Over Alarm:** - If a chart over alarm option is enabled in the Alarm selection and there are 10 minutes remaining for the chart to over, the buzzer will sound every 5 minutes until the device is reset for changing the chart.

- 2) **High / Low Temperature Alarm:** - When temperature reading exceeds the High / Low Alarm limit, the instrument waits for 10 minutes and activates the buzzer. If the readings persist beyond the limit, the buzzer sounds again every 1 hour for 15 hours. After that, buzzer will be deactivated until temperature gets within the Alarm limits and alarm condition occurs again.

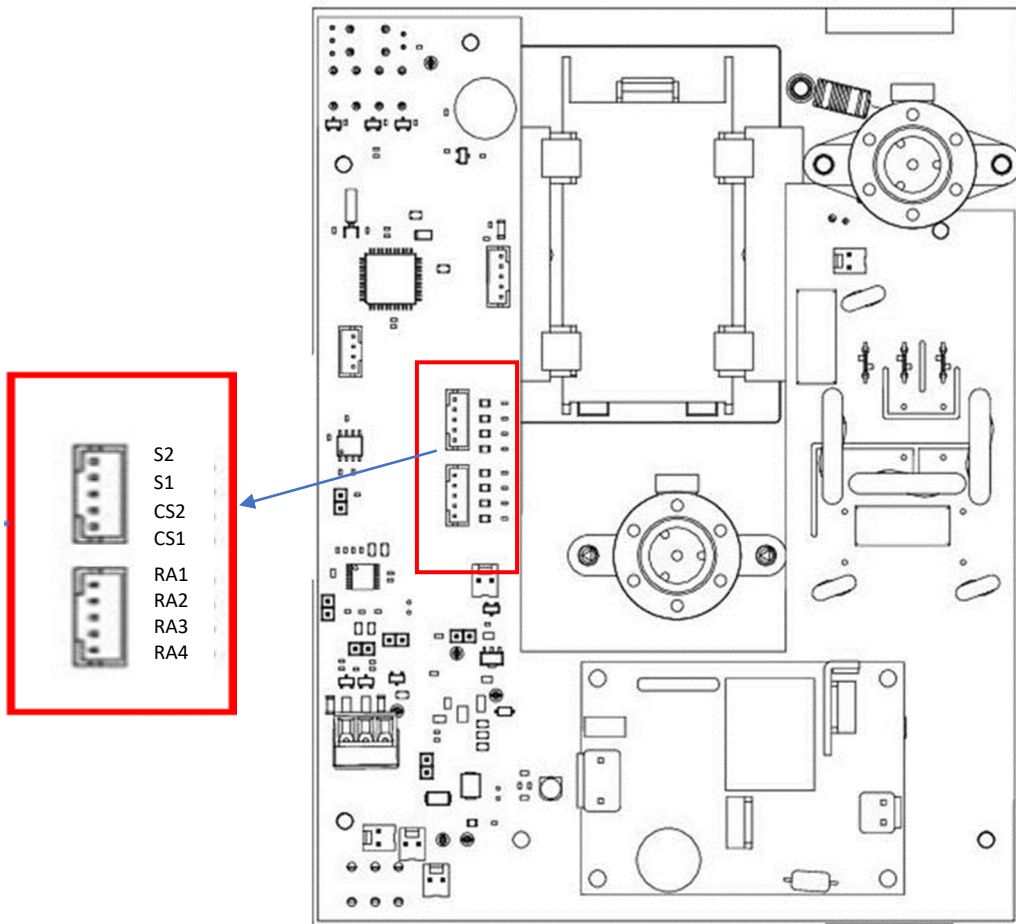

Figure 10 - Chart Parameters Settings LED Indication

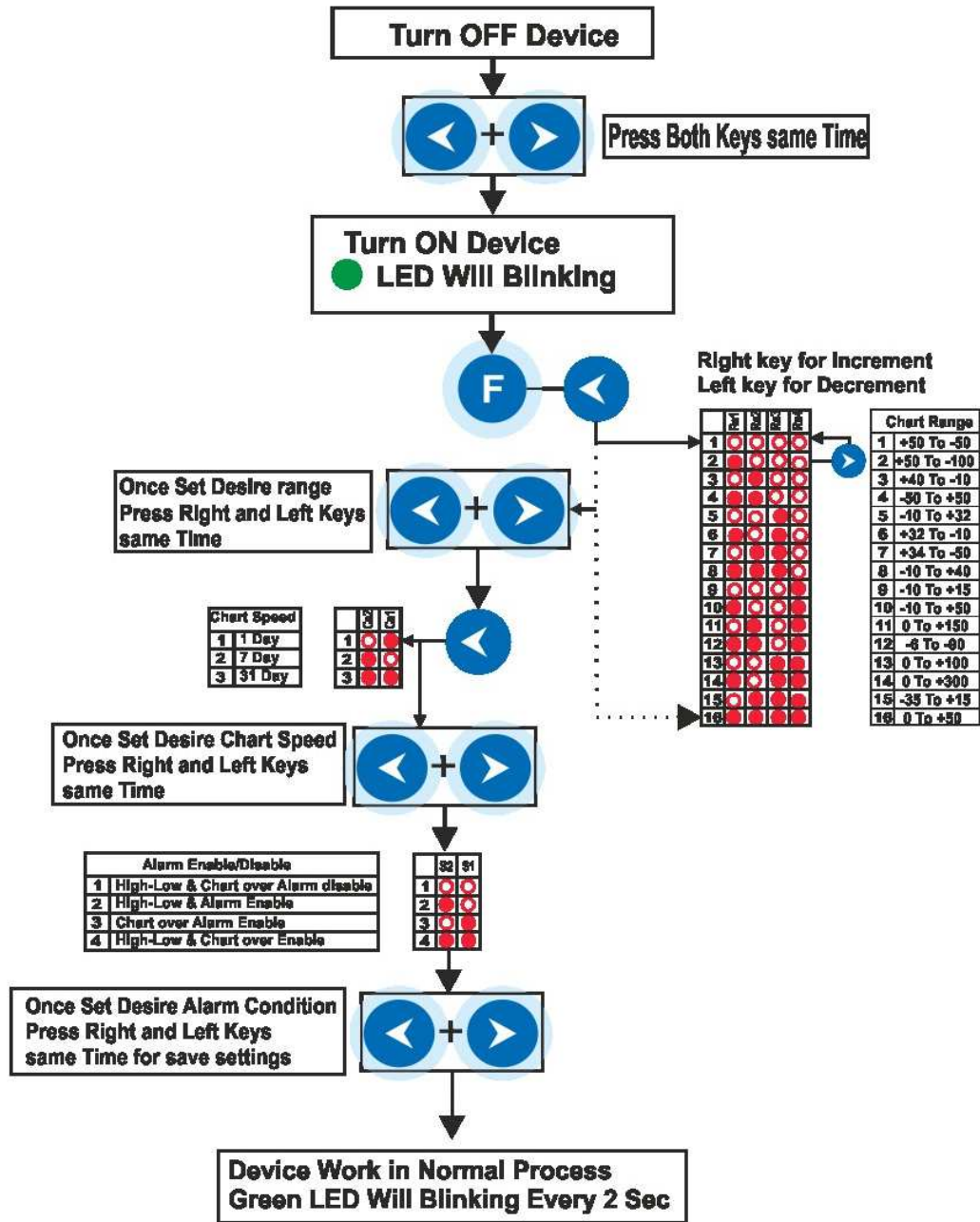

Figure 11 - Chart Parameters settings sequence

NOTE: Current available sensor type is RTD, Pt-100, $\alpha=.00385$ only.

6 CALIBRATION

6.1 MECHANICAL CALIBRATION

This involves setting of pen at zero and pen at full scale on the chart, through the front panel keyboard. The user can calibrate the recorder by following the sequence shown in figure 12.

- Press Left + Right key and turn ON the recorder for main menu.
- After that, press Left +Right Key at a time for entering Mechanical Calibration Menu.
- Pen goes to Zero (Range Low) scale. Set the Zero (Range Low) scale using Left or Right Key.
- Press Left + Right key for saving Zero scale (Range Low) calibration.
- Pen goes to Full scale. Set the full scale using Left or Right Key.
- Press Left + Right key to Save Full scale calibration.
- Pen goes to Zero scale. Once the pen is located at Zero scale, restart the recorder.

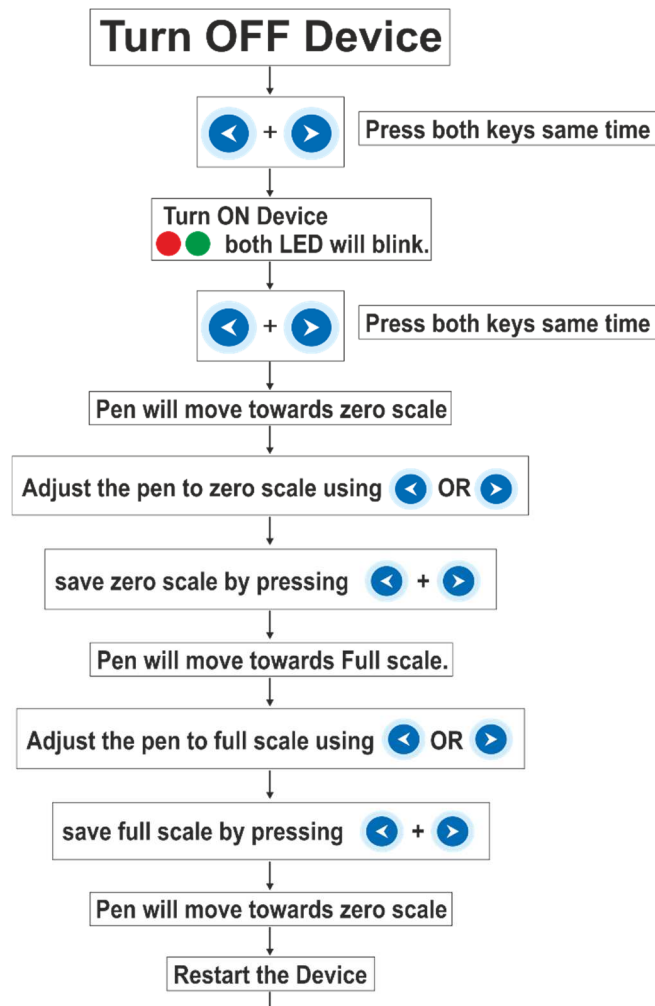

Figure 12 - Mechanical Calibration sequence

NOTE:

1. If any key press is not detected within 30 seconds, then the recorder automatically exits from the menu and recorder will start normal operation.
2. If the error is large, you may need to carry out same exercise twice or thrice to set the value properly.

6.2 ELECTRICAL CALIBRATION (OFFSET)

This involves aligning the pen to the known parameter value on the chart, through the front panel keyboard. The user can calibrate the recorder by following the sequence as shown in figure 13.

- Press Left + Right key and turn ON the recorder for main menu.
- After that, press Left key to enter the Electrical calibration menu.
- Pen moves to Zero scale (range Low) and after that pen move to locate at actual reading.
- Press Left Key or Right Key for $\pm 1 \text{ Deg } ^\circ\text{C}$ Offset (Maximum offset of $\pm 12 \text{ Deg } ^\circ\text{C}$ is allowed).
- Press Left + Right key for saving Offset value.
- Restart the recorder.

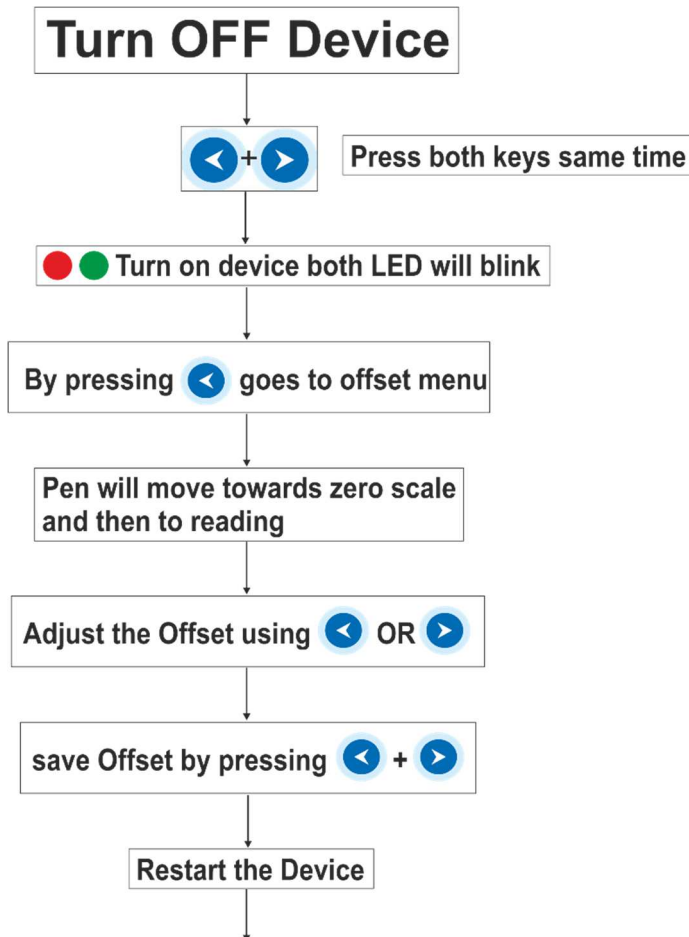

Figure 13 - Offset Settings sequence

NOTE:

1. If any key press is not detected within 30 seconds, then the recorder automatically exits from the menu and recorder will start normal operation.
2. If the error is large, you may need to carry out same exercise twice or thrice to set the value properly.

6.3 PEN PARK

This feature is used to change the chart position and replace the pen if required. In Pen Park, the pen is moved to full scale from current reading position (refer to figure 14).

- Press Left + Right key and turn ON the recorder for main menu.
- For entering Pen Park menu, press Right key.
- Pen goes to Zero scale (Range Low) and after that pen move to locate at full scale.
- Press Left or Right Key to rotate the Chart counterclockwise or clockwise respectively.
- Press Left + Right key to start normal operation. Ensure that the chart range and speed are selected properly.

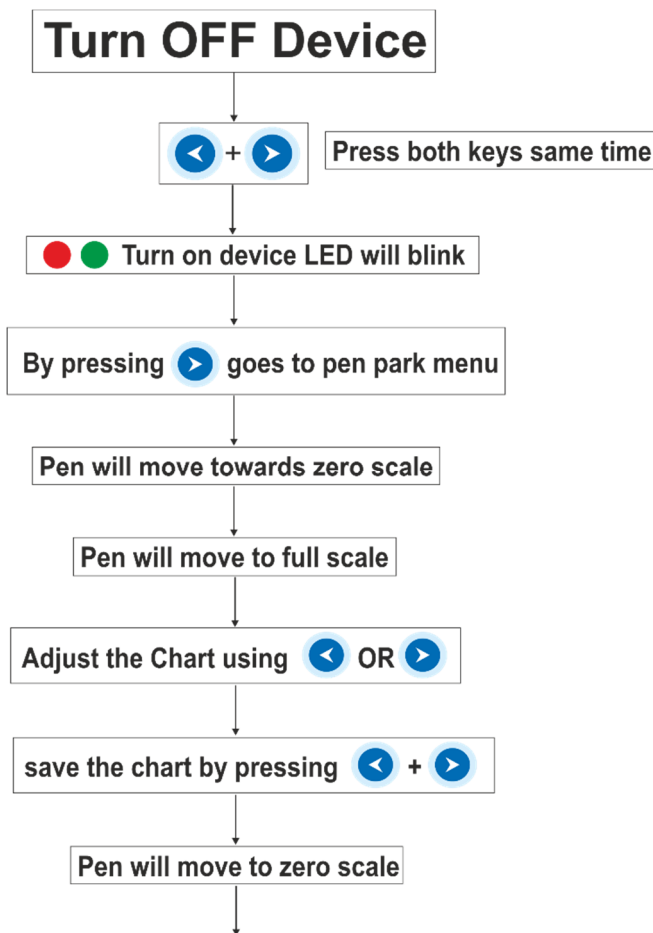

Figure 14 - Pen-Park Function sequence

7 BATTERY INSTALLATION/REPLACEMENT

7.1 BATTERY CHANGE

Follow the steps to change/install the batteries as shown in figure 15.

- Switch off the chart recorder and disconnect the Mains power supply.
- Remove the chart from the chart plate and open the battery compartment.
- Replace the old batteries with the new batteries (recommended by manufacturer).
- Place the chart again and switch on the chart recorder.

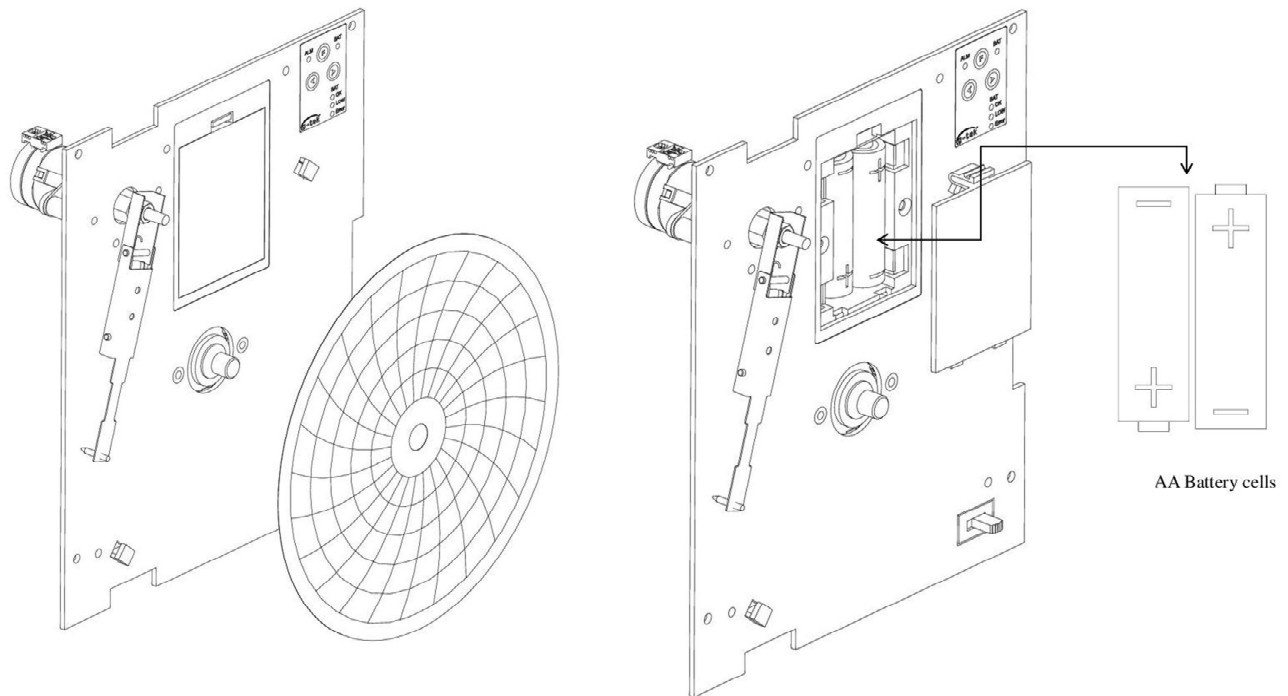

Figure 15 - Battery Replace

7.2 BATTERY LIFE

The Chart Recorder contains Ultimate Lithium Batteries. When the battery is Low, it is indicated by BAT LED blinking in Red instead of Green color at every 2 seconds. The user should replace the batteries within 7 days from the battery low indication.

If the batteries are not replaced within specified time, **BAT LED** will remain ON in Red color and the plotting of the sensor input would be stopped.

Dispose or recycle the battery in accordance with your local regulations.

Do not expose the Data Logger to extreme temperatures as it may lead to the destruction of the battery and may cause injuries.

To prevent the possibility of the battery from leaking, heating, explosion, please observe the following precautions:

- Please check the positive and negative polarity before placing the cell.
- Do not use or leave the battery in very high temperature conditions (e.g., strong direct sunlight or a vehicle in extremely hot conditions). Otherwise, it can overheat or catch fire or its performance will degenerate and its service life will be decreased.
- Do not disassemble or modify the cell.
- Do not transport or store the battery together with metal objects.
- Make sure the cell is not with conspicuous damage or deformation.
- Mixed use of batteries of different types is not advised.
- Do not directly solder the battery and pierce the battery with a nail or other sharp object.
- Use of damaged cells is not permitted.

“Warning, Battery may explode if mistreated. Do not disassemble or dispose of in fire.”

NOTE: Mains + Battery operated recorder has battery backup of 7 Days** in Normal Operation.

** Battery life Depends On number of time recorder on/off and sensor input Variation and Alarm generation.

8 TROUBLESHOOTING GUIDE

Table 5 - Troubleshooting Guide

Problem	Corrective Action
Power is ON but LED does not blink.	<ul style="list-style-type: none">▪ Check recorder switch whether it is ON or OFF.▪ Check Battery Voltage.▪ Check Battery polarity.
Pen is not marking on the chart.	<ul style="list-style-type: none">▪ Check pen arm pressure.
The chart does not move.	<ul style="list-style-type: none">▪ The chart knob might be loose, tighten the knob.▪ Chart motor is having problem, contact G-Tek.
Reading is not stable.	<ul style="list-style-type: none">▪ Replace the sensor with fixed known input. If the problem is solved, check and replace the sensor if required.▪ If problem persists, contact G-Tek.
Pen does not respond to the input.	<ul style="list-style-type: none">▪ Check for the range of the recorder and ensure that the input is within the chart range.▪ If the input is within the chart range, carry out the mechanical calibration.▪ If problem persists, contact G-Tek.
Recorder not Working on battery.	<ul style="list-style-type: none">▪ Battery voltage is not enough.▪ Check battery polarity.
Calibration settings cannot be performed.	<ul style="list-style-type: none">▪ Contact G-Tek.

9 ACCESSORIES

9.1 STANDARD ACCESSORIES

Circular Chart Pack of 30: 1 (Refer Table 8 for the chart range and part no.)

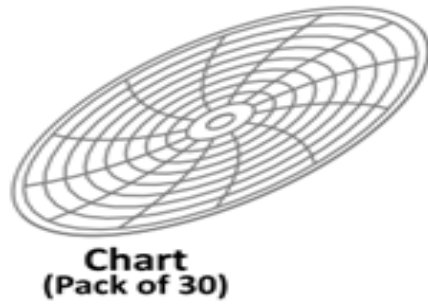

Figure 16 - Standard Accessories

10 SPECIFICATIONS

The full specifications of the chart recorder are given in the table below.

Table 6 - Specification of Chart Recorder

Model No	CR-2010 Pro Series Circular Chart Recorder
Product code	9994x-xx001
Pens	
No. of Pens	1
Pen marking	Continuous
Pen Response Time	< 10 Sec. (Full Scale)
Pen Resolution	Stepper Motor Controlled better than 0.1% FSD
Overshoot	None
Chart	
Chart Speed	In day mode — 1 day/ 7 days/ 31days per revolution
User setting	User programmable(configurable)
Chart Calibrated Radius/ Size	2.3 " (calibrated radius approx. 59 mm) / Circular, 5.51" (140 mm)
Chart Ranges	Refer Table 7 and Table 8
Display, Operator Panels and Inputs	
Display Type	None
Status Indicators	ALM LED – Red LED blinking indicates Alarm high/low condition BAT LED - Green LED blinking indicates Normal Operation Red LED blinking indicates Battery Low status Yellow LED blinking indicates Error condition
Panel Keys	Front panel Keyboard consisting of three keys for configuration and calibration
Number of Analog Input	1
Analog Input (Sensor)	RTD (PT-100)
Sensor Type and Range	Refer to Table 9
Scan Rate	Mains + Battery: Continuous 1 reading per 2 seconds for 1 Day, 7 Days and 31 Days chart speed
Protection	
Input Impedance RTD	> 20 MΩ
CMRR	> 115 dB @ 50, 60 Hz at 20 sample per second
NMRR	> 88 dB @ 50, 60 Hz at 20 sample per second
Maximum Common Mode Voltage	5V AC

Isolation Channel-EARTH	NA
Input Protection	30V AC/DC Max
Environmental	
Temperature	(Operation) +5°C to +45°C (Limiting) 0°C to +50°C. (Storage) -20°C to +60°C
Humidity	(Operation) 10 to 80 % RH Non-Condensing (Storage) 5 to 90 % RH Non-Condensing
Altitude	<2000 meter
Power Requirement	
Mains Supply + Internal Battery Model	Power Supply: 85 to 264 VAC ,47-63 Hz. Battery : 2x1.5 VDC Ultimate Lithium Non rechargeable battery 3500 mAh
Power Rating	3 V, 300 mA (Max) ; 1 W Max with maximum configuration
Fuse Type	None
Battery Reverse Polarity	Protected
Battery backup	7 days**
Standards	
EMI-EMC	IEC 61000-6-2/6-3
Safety	IEC 61010-1
Pollution Degree	II
Installation Category	II
Vibration	2g Peak (10Hz-150Hz)
Shock	IEC 61010-1
Physical Characteristics	
Overall Dimensions Max L x W x D (mm)	191 x 163 x 66 mm
Weight	Approx. 1 kg (with Sensor and battery)
Mounting	Panel Mount

** Battery life is calculated assuming process parameter does not vary more than 0.15 Deg/Min and recorder is not turned OFF or ON And the sensor input is not alarming condition. (Battery life depends on number of times recorder on/off and sensor input Variation and alarm condition.)

Table 7 - Programmable(configurable) Chart Ranges

(Refer to [section 5.3](#) for how to select the chart range)

Chart Type xx	Chart Range***
01	+50 to -50
02	+50 to -100
03	+40 to -10
04	-50 to +50
05	-10 to +32
06	+32 to -10
07	+34 to -50
08	-10 to +40
09	-10 to +15
10	-10 to +50
11	0 to 150
12	-6 to -90
13	0 to 100
14	0 to 300
15	+30 to -40
16	0 to +50

*** First value in the chart range is at the center of the chart.

Table 8 - Available Chart(s) and their ranges

Chart Type xx	Range***	Part Description
41	0 to + 50 (PS)	W6 0 +50 PS
42	+30 to -40 (PS)	W6 +30 -40 PS
43	-40 to +25 (PS)	W6 -40 +25 PS
44	-115 to +50 (PS)	W6 -115 +50 PS
45	-200 to 0 (PS)	W6 -200 0 PS
46	0 to +60 (PS)	W6 0 +60 PS
	Others, Please Specify	

Table 9 - Sensor Type and Range

Sensor Type	Valid Input Range	Resolution	Accuracy	Linearization Error
Pt-100 (RTD)#	-200 to 850 °C	1 %	± 0.5 % FSD	± 0.06 °C Max

$\alpha = 0.00385$

11 ORDER CODE

The Order code for the chart recorder is as below:

Table 10 - Order code

9	9	9	4	5	-	xx	0	4	1
---	---	---	---	---	---	----	---	---	---

